

Owner's Manual & Safety Instructions

Save This Manual Keep this manual for the safety warnings and precautions, assembly, operating, inspection, maintenance and cleaning procedures. Write the product's serial number in the back of the manual near the assembly diagram (or month and year of purchase if product has no number). Keep this manual and the receipt in a safe and dry place for future reference.

21d

DAYTONA™

3 TON HEAVY DUTY

LOW PROFILE LONG REACH FLOOR JACK

DS300LRB



Visit our website at: <http://www.harborfreight.com>
Email our technical support at: productsupport@harborfreight.com

64781

When unpacking, make sure that the product is intact and undamaged. If any parts are missing or broken, please call 1-888-866-5797 as soon as possible.

Copyright© 2021 by Harbor Freight Tools®. All rights reserved.
No portion of this manual or any artwork contained herein may be reproduced in any shape or form without the express written consent of Harbor Freight Tools. Diagrams within this manual may not be drawn proportionally. Due to continuing improvements, actual product may differ slightly from the product described herein.
Tools required for assembly and service may not be included.

⚠ WARNING

Read this material before using this product.
Failure to do so can result in serious injury.
SAVE THIS MANUAL.

IMPORTANT SAFETY INFORMATION

1. Study, understand, and follow all instructions before operating this device.
2. Do not exceed rated capacity.
3. Use only on hard, level surfaces.
4. Lifting device only. Immediately after lifting, support the vehicle with appropriate means.
5. Do not move or dolly the vehicle while on the jack.
6. Failure to heed these markings may result in personal injury and/or property damage.
7. Lift only areas of the vehicle as specified by the vehicle manufacturer.
8. No alterations shall be made to this product.
9. Never work on, under or around a load supported only by this device.
10. Do not adjust safety valve.
11. Wear ANSI-approved safety goggles and heavy-duty work gloves during use.
12. Keep clear of load while lifting and lowering.
13. Lower load slowly.
14. Apply parking brake and chock tires before lifting vehicle.
15. Lift vehicle only at manufacturer recommended locations.
16. Inspect before every use; do not use if parts are loose or damaged, or if leaking hydraulic fluid.
17. Do not use for aircraft purposes.
18. Do not use any objects (such as blocks of wood) in between Saddle Pad or Saddle and lifting point. Objects placed on the Saddle will reduce the stability of the Jack, and could allow the vehicle to slip off the Saddle and fall.
19. The warnings, precautions, and instructions discussed in this manual cannot cover all possible conditions and situations that may occur. The operator must understand that common sense and caution are factors, which cannot be built into this product, but must be supplied by the operator.
20. The Handle socket may be held down by a clip under tension. Wear ANSI-approved safety goggles before freeing Handle socket. Remove clip carefully.







SAVE THESE INSTRUCTIONS.

IMPORTANT! Before first use:

Check hydraulic oil level and fill as needed as stated on page 6. Thoroughly test the Jack for proper operation. If it does not work properly, bleed air from its hydraulic system as stated on page 6.

WARNING SYMBOLS AND DEFINITIONS

	This is the safety alert symbol. It is used to alert you to potential personal injury hazards. Obey all safety messages that follow this symbol to avoid possible injury or death.
	Indicates a hazardous situation which, if not avoided, will result in death or serious injury.
	Indicates a hazardous situation which, if not avoided, could result in death or serious injury.
	Indicates a hazardous situation which, if not avoided, could result in minor or moderate injury.
	Addresses practices not related to personal injury.

DAYTONATM

Specifications

Weight Capacity	3 Tons
Weight Capacity (lb.)	6,000
Maximum Height (in.)	24.25
Minimum Height (in.)	3.25
Handle Length (in.)	50
Hydraulic Oil	non-detergent 22 weight
Weight (lb.)	103

DAYTONATM

Overview

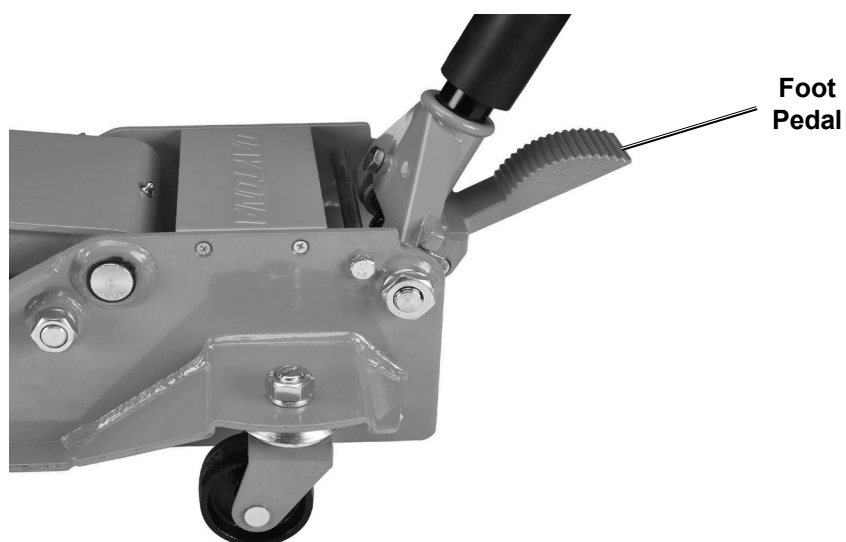
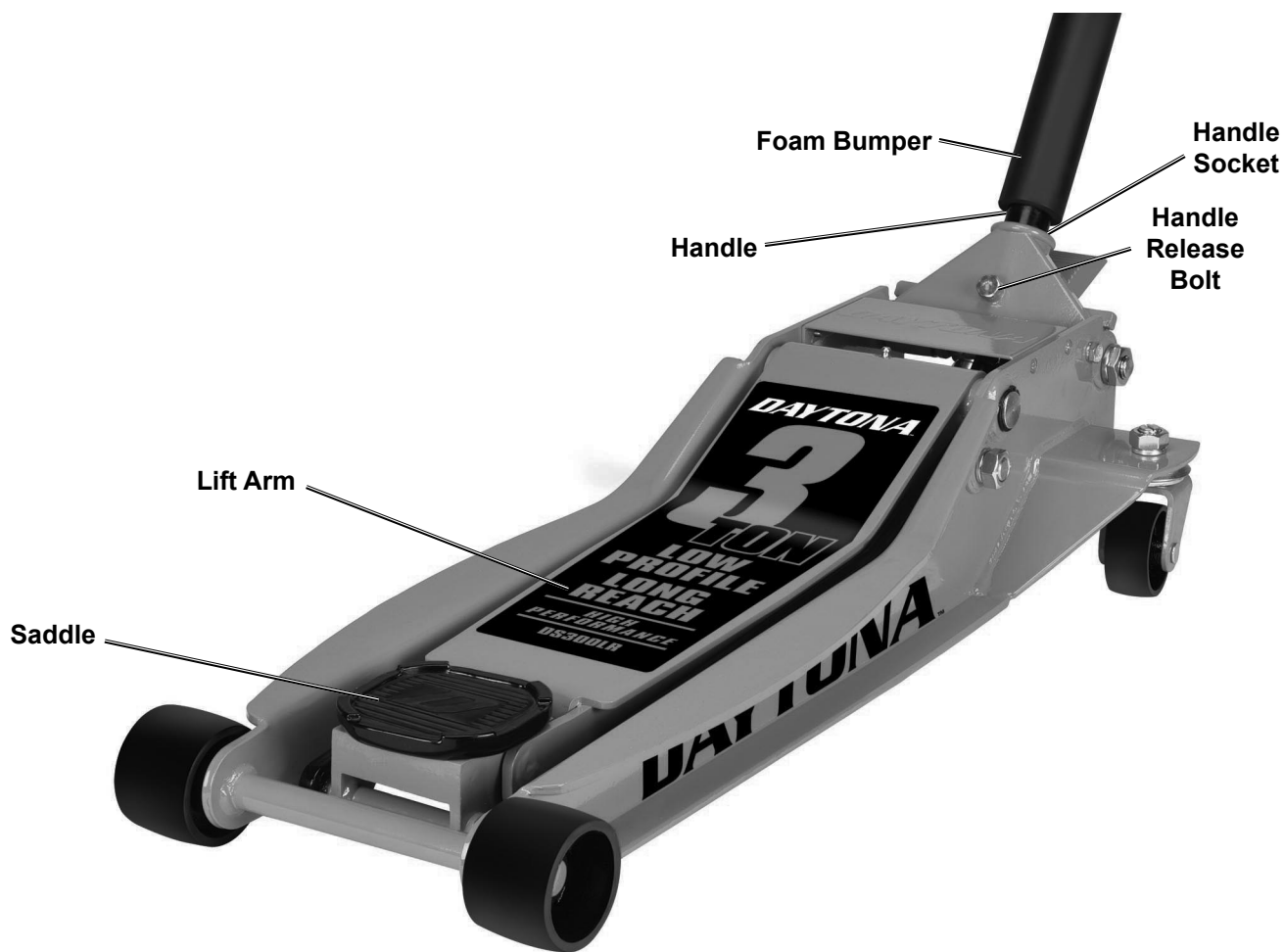

Set Up



Read the **ENTIRE IMPORTANT SAFETY INFORMATION** section at the beginning of this manual including all text under subheadings therein before set up or use of this product.

Removing Shipping Block

CAUTION! The Handle socket is held down by a plastic block. Wear ANSI-approved safety goggles before freeing Handle socket. Remove block carefully.

A plastic block holds the Handle Socket in position during shipment. This helps prevent shipping damage. To remove it:

1. Insert the Handle into Handle Socket.
2. Press down on Handle.
3. Remove the plastic block.
4. Return Handle to original position.

Attaching the Handle

1. Slide the Upper Handle into the Lower Handle. Line the Button on the Lower Handle up with the hole in the Upper Handle until it clicks into place.
2. Loosen the Handle Release Bolt and insert the grooved end of the Handle into the Handle Socket.
3. Tighten the Handle Release Bolt. Gently pull up on the Handle to make sure that it is secure.

Bleeding Trapped Air

1. With the Jack fully lowered, remove both Screws on the end of the Cover Plate that is closer to the Saddle. Swing the Cover Plate open. See Figure A.
2. Remove the Fill Plug on top of the Cylinder. Check that the oil level inside the Cylinder is at the top of the Piston. See Figure B.
3. Insert the Handle into the Handle Socket to operate the Release Valve.
4. Turn the Handle counterclockwise to open the valve.
5. Pump the Handle up and down quickly 10-15 times to force air from the system.
6. Replace the Fill Plug, close the Cover Plate, and reinstall the Screws.

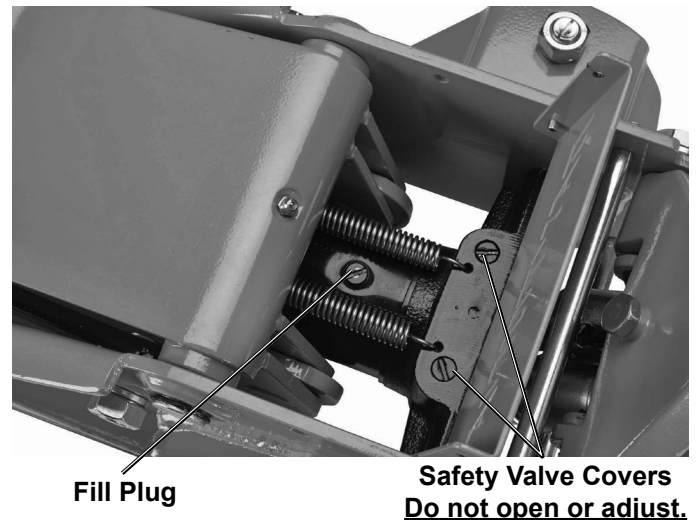

Figure A: Hydraulic Unit

Adding Oil

NOTICE: To prevent damage and premature wear, use only non-detergent 22 weight hydraulic jack oil.

1. With the Jack fully lowered, remove both Screws on the end of the Cover Plate that is closer to the Saddle. Swing the Cover Plate open.
2. Remove the Fill Plug on top of the Cylinder.
3. Add non-detergent 22 weight hydraulic jack oil into the Fill Plug hole slowly until the oil level just covers the top of the Piston inside the Cylinder.
4. Replace the Fill Plug, close the Cover Plate, and reinstall the Screws.

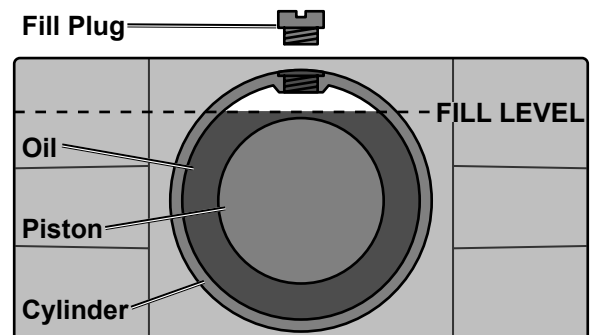

Figure B: Fill Level



Read the **ENTIRE IMPORTANT SAFETY INFORMATION** section at the beginning of this manual including all text under subheadings therein before set up or use of this product.

Lifting

⚠ WARNING

Park vehicle on a flat, level, solid, surface safely away from oncoming traffic. Turn off the vehicle's engine. Place the vehicle's transmission in "PARK" (if automatic) or in its lowest gear (if manual). Set the vehicle's emergency brake. Then, chock the wheels that are not being lifted.

1. Turn the Handle counterclockwise to lower the Jack. Once the Jack is fully lowered, turn the Handle firmly clockwise to close it.
2. Carefully position the Saddle of the Jack under the vehicle manufacturer's recommended lifting point. (See vehicle manufacturer's owner's manual for location of frame lifting point.)
3. Step on Foot Pedal until the top of the Jack's Saddle has nearly reached the vehicle lifting point. Position the Saddle directly under the vehicle's lifting point.
4. To lift the vehicle, pump the Handle. Use smooth, full strokes.
5. Once the vehicle is raised, slide a jack stand of appropriate capacity (not included) under a proper lifting point referred to in the vehicle owner's manual. Always use two jack stands, position them at the same point on each side of the vehicle.
6. Center saddle of the jack stand(s) under the vehicle's lifting point(s). Set the jack stand(s) to the same height according to the manufacturer's instructions, making sure that they lock securely into position.
7. Slowly turn the Handle counterclockwise to lower the vehicle onto the saddle(s) of the jack stand(s). Then, turn the Handle firmly clockwise to close it.

Lowering

1. Carefully remove all tools, parts, etc. from under the vehicle.
2. Position the Saddle under the lifting point. Turn the Handle firmly clockwise and raise load high enough to clear the jack stands, then carefully remove jack stands.
3. Slowly turn the Handle counterclockwise (never more than 1/2 full turn) to lower the vehicle onto the ground.
4. Lower the Jack completely. Then, store in a safe, dry location out of reach of children.

Maintenance and Servicing



Procedures not specifically explained in this manual must be performed only by a qualified technician.

WARNING

TO PREVENT SERIOUS INJURY FROM TOOL FAILURE: Do not use damaged equipment. If abnormal noise or vibration occurs, have the problem corrected before further use.

- BEFORE EACH USE**, inspect the general condition of the tool. Check for:
 - leaking hydraulic oil,
 - loose hardware or parts,
 - misalignment or binding of moving parts,
 - cracked, bent or broken parts, and
 - any other condition that may affect its safe operation.
- AFTER USE**, wipe dry with a clean cloth. Then, store the Jack in a safe, dry location out of reach of children and other non-authorized people.

Thoroughly investigate and correct the causes for all issues that are found. Do not use Jack until all issues are understood and properly corrected.

ALSO, BEFORE EACH USE, thoroughly test the Jack for proper operation prior to actual use. If the Jack's motion seems spongy or the Saddle does not lift completely, follow Bleeding instructions on page 6.

NOTICE: Storing the Jack in a humid area or exposing it to corrosive vapor voids the warranty.

3. Weekly - Jack Lubrication:

- Lubricate according to the below steps using only general purpose lithium grease.
- Inject grease into each of the grease fittings.
- Lubricate the linkages and pivot points lightly.

Note: Improper or inadequate lubrication voids the warranty.

- Change the hydraulic oil at least once every three years:
 - With the Jack fully lowered, remove both Screws on the end of the Cover Plate that is closer to the Saddle. Swing the Cover Plate open.
 - Remove the Fill Plug on the top of the Cylinder.
 - Tip the Jack to allow the old hydraulic oil to drain out of the Housing completely, and dispose of the old hydraulic oil in accordance with local regulations.
 - Follow instructions for Adding Oil on page 6.
 - Replace the Fill Plug, close the Cover Plate, and reinstall the Screws.
 - Follow instructions for Bleeding Trapped Air on page 6.

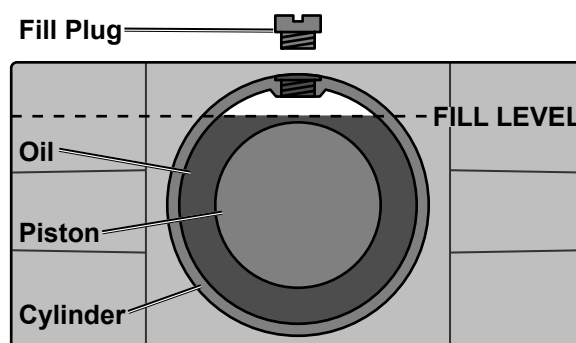

Figure C: Fill Level

⚠️ WARNING

TO PREVENT SERIOUS INJURY:

Use caution when troubleshooting a malfunctioning jack. Stay well clear of the supported load. Completely resolve all problems before use. If the solutions presented in the Troubleshooting guide do not solve the problem, have a qualified technician inspect and repair the jack before use.

After the jack is repaired: Test it carefully without a load by raising and lowering it fully, checking for proper operation, **BEFORE RETURNING THE JACK TO OPERATION.**

DO NOT USE A DAMAGED OR MALFUNCTIONING JACK!

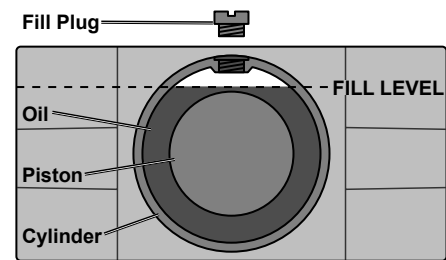
POSSIBLE SYMPTOMS					PROBABLE SOLUTION (Jack must not be supporting a load while attempting a solution.)
Jack will not lift at capacity	Saddle lowers under load	Pump stroke feels spongy or Saddle does not lift all the way	Handle moves up when Jack under load	Fill Plug leaking oil or Jack will not lower without a load	
X	X				Check that Release Valve is fully closed. Bleed trapped air from the hydraulics.
X	X		X		Valves may be blocked and may not close fully. To flush the valves: 1. Lower the Saddle and securely close the Release Valve. 2. Manually lift the saddle several inches. 3. Open the release valve and force the saddle down as quickly as possible.
X		X			Jack may be low on oil. Check the oil level and fill if needed. See step 4 on facing page.
					Jack may have air trapped in the hydraulics. Follow instructions for Bleeding Trapped Air on page 6.
				X	Jack may have too much hydraulic oil inside, check oil level and adjust if needed. 

PLEASE READ THE FOLLOWING CAREFULLY

THE MANUFACTURER AND/OR DISTRIBUTOR HAS PROVIDED THE PARTS LIST AND ASSEMBLY DIAGRAM IN THIS MANUAL AS A REFERENCE TOOL ONLY. NEITHER THE MANUFACTURER OR DISTRIBUTOR MAKES ANY REPRESENTATION OR WARRANTY OF ANY KIND TO THE BUYER THAT HE OR SHE IS QUALIFIED TO MAKE ANY REPAIRS TO THE PRODUCT, OR THAT HE OR SHE IS QUALIFIED TO REPLACE ANY PARTS OF THE PRODUCT. IN FACT, THE MANUFACTURER AND/OR DISTRIBUTOR EXPRESSLY STATES THAT ALL REPAIRS AND PARTS REPLACEMENTS SHOULD BE UNDERTAKEN BY CERTIFIED AND LICENSED TECHNICIANS, AND NOT BY THE BUYER. THE BUYER ASSUMES ALL RISK AND LIABILITY ARISING OUT OF HIS OR HER REPAIRS TO THE ORIGINAL PRODUCT OR REPLACEMENT PARTS THERETO, OR ARISING OUT OF HIS OR HER INSTALLATION OF REPLACEMENT PARTS THERETO.

Parts List

Part	Description	Qty.
1	Retainer Ring	2
2	Washer	2
3	Wheel	2
4	Chassis	1
5	Lifting Frame	1
6	Saddle	1
7	Retainer Ring	2
8	Bar	1
9	Pin	1
10	Retainer Ring	2
11	Axle	1
12	Nut	2
13	Lock Washer	4
14	Bolt	1
15	Lock Washer	1
16	Bolt	4
17	Lock Washer	4
18	Bar	2
19	Bolt	4
20	Lock Washer	4
21	Lock Washer	2
22	Pump	1

Part	Description	Qty.
23	Screw	2
24	Retainer Ring	2
25	Plate	2
26	Screw	4
27	Cover	1
28	Screw	1
29	Handle Socket	1
30	Retainer Ring	1
31	Pedal	1
32	Roller Wheel	1
33	Pin	1
34	Bolt	1
35	Grease Cup	1
36	Spring	2
37	Spring	1
38	Screw	1
39	Upper Handle	1
40	Lower Handle	1
41	Foam	1
42	Pin	1
43	Rubber Pad	1
44	Washer	2
45	Lock Washer	1

Record Product's Serial Number Here: _____

Note: If product has no serial number, record month and year of purchase instead.

Note: Some parts are listed and shown for illustration purposes only, and are not available individually as replacement parts. Specify UPC 792363647816 when ordering parts.

Assembly Diagram

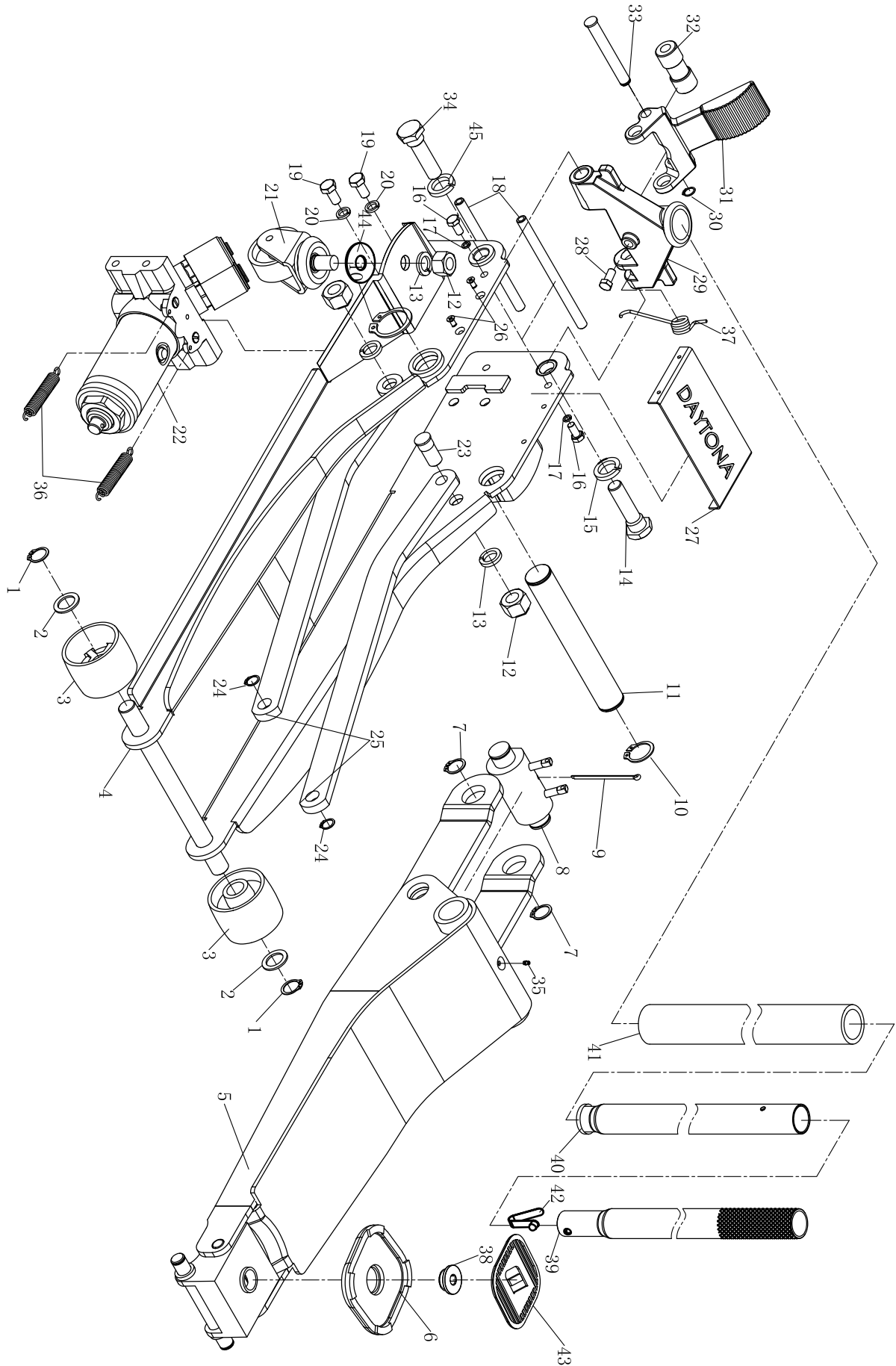

Limited 90 Day Warranty

Harbor Freight Tools Co. makes every effort to assure that its products meet high quality and durability standards, and warrants to the original purchaser that this product is free from defects in materials and workmanship for the period of 90 days from the date of purchase. This warranty does not apply to damage due directly or indirectly, to misuse, abuse, negligence or accidents, repairs or alterations outside our facilities, criminal activity, improper installation, normal wear and tear, or to lack of maintenance. We shall in no event be liable for death, injuries to persons or property, or for incidental, contingent, special or consequential damages arising from the use of our product. Some states do not allow the exclusion or limitation of incidental or consequential damages, so the above limitation of exclusion may not apply to you. THIS WARRANTY IS EXPRESSLY IN LIEU OF ALL OTHER WARRANTIES, EXPRESS OR IMPLIED, INCLUDING THE WARRANTIES OF MERCHANTABILITY AND FITNESS.

To take advantage of this warranty, the product or part must be returned to us with transportation charges prepaid. Proof of purchase date and an explanation of the complaint must accompany the merchandise. If our inspection verifies the defect, we will either repair or replace the product at our election or we may elect to refund the purchase price if we cannot readily and quickly provide you with a replacement. We will return repaired products at our expense, but if we determine there is no defect, or that the defect resulted from causes not within the scope of our warranty, then you must bear the cost of returning the product.

This warranty gives you specific legal rights and you may also have other rights which vary from state to state.

DAYTONATM

26541 Agoura Road • Calabasas, CA 91302 • 1-888-866-5797