

Owner's Manual & Safety Instructions

Save This Manual Keep this manual for the safety warnings and precautions, assembly, operating, inspection, maintenance and cleaning procedures. Write the product's serial number in the back of the manual near the assembly diagram (or month and year of purchase if product has no number). Keep this manual and the receipt in a safe and dry place for future reference.

19j

PITTSBURGH[®] MOTORCYCLE

64926

350 LB. CAPACITY MOTOCROSS DIRT BIKE STAND



Visit our website at: <http://www.harborfreight.com>
Email our technical support at: productsupport@harborfreight.com

When unpacking, make sure that the product is intact and undamaged. If any parts are missing or broken, please call 1-888-866-5797 as soon as possible.

Copyright© 2019 by Harbor Freight Tools®. All rights reserved.
No portion of this manual or any artwork contained herein may be reproduced in any shape or form without the express written consent of Harbor Freight Tools. Diagrams within this manual may not be drawn proportionally. Due to continuing improvements, actual product may differ slightly from the product described herein.
Tools required for assembly and service may not be included.

⚠ WARNING

Read this material before using this product.
Failure to do so can result in serious injury.
SAVE THIS MANUAL.

IMPORTANT SAFETY INFORMATION

In this manual, on the labeling, and all other information provided with this product:



This is the safety alert symbol. It is used to alert you to potential personal injury hazards. Obey all safety messages that follow this symbol to avoid possible injury or death.

⚠ DANGER

DANGER indicates a hazardous situation which, if not avoided, will result in death or serious injury.

⚠ WARNING

WARNING indicates a hazardous situation which, if not avoided, could result in death or serious injury.

⚠ CAUTION

CAUTION, used with the safety alert symbol, indicates a hazardous situation which, if not avoided, could result in minor or moderate injury.

NOTICE

NOTICE is used to address practices not related to personal injury.

CAUTION

CAUTION, without the safety alert symbol, is used to address practices not related to personal injury.

General Safety Warnings



WARNING Read all safety warnings and instructions.

Failure to follow the warnings and instructions may result in serious injury.

Save all warnings and instructions for future reference.

1. **Work area safety**
 - a. **Keep work area clean and well lit.** *Cluttered or dark areas invite accidents.*
 - b. **Keep children and bystanders away while operating a tool.** *Distractions can cause you to lose control.*
2. **Personal safety**
 - a. **Stay alert, watch what you are doing and use common sense when operating a tool. Do not use a tool while you are tired or under the influence of drugs, alcohol or medication.** *A moment of inattention while operating tools may result in serious personal injury.*
 - b. **Use personal protective equipment. Always wear eye protection.** *Safety equipment such as dust mask, non-skid safety shoes, hard hat, or hearing protection used for appropriate conditions will reduce personal injuries.*
 - c. **Do not overreach. Keep proper footing and balance at all times.** *This enables better control of the tool in unexpected situations.*
 - d. **Dress properly. Do not wear loose clothing or jewelry. Keep your hair, clothing and gloves away from moving parts.** *Loose clothes, jewelry or long hair can be caught in moving parts.*
 - e. **Only use safety equipment that has been approved by an appropriate standards agency.** *Unapproved safety equipment may not provide adequate protection. Eye protection must be ANSI-approved and breathing protection must be NIOSH-approved for the specific hazards in the work area.*

Motocross Bike Stand Safety Warnings

1. Strap load to Saddle before lifting.
2. Keep clear of Release Bar and do not leave unattended while supporting load.
3. Do not exceed 350 lb. capacity.
4. Center load on Saddle.
5. Raise and lower using second person to stabilize load.
6. Be sure to insert Locking Pin fully. Do not use any other object in place of the Locking Pin.
7. Keep out from under load while lowering.
8. Inspect before every use; do not use if parts are loose or damaged.
9. Use as intended only.
10. Operate on flat and level surface.
11. Do not rock load on Stand.
12. Keep out of reach of children.
13. Maintain labels and nameplates on the tool. These carry important safety information. If unreadable or missing, contact Harbor Freight Tools for a replacement.
14. The warnings, precautions, and instructions discussed in this instruction manual cannot cover all possible conditions and situations that may occur. It must be understood by the operator that common sense and caution are factors which cannot be built into this product, but must be supplied by the operator.



SAVE THESE INSTRUCTIONS.

Specifications

Weight Capacity

350 lb

ASSEMBLY



Read the **ENTIRE IMPORTANT SAFETY INFORMATION** section at the beginning of this manual including all text under subheadings therein before set up or use of this product.

Note: For additional information regarding the parts listed in the following pages, refer to the Assembly Diagram near the end of this manual.

1. Slide the Foot Pedal Assembly's shaft through the large hole in the Base's top bracket.

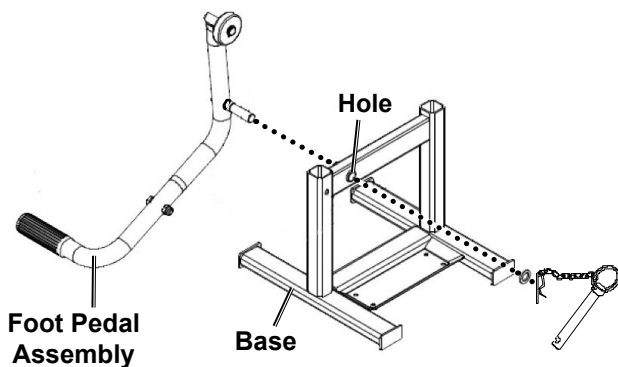

2. Slide a Flat Washer (7) onto the Foot Pedal Assembly's shaft on the other side of the hole and secure it in place with the R-Pin (8) assembly.

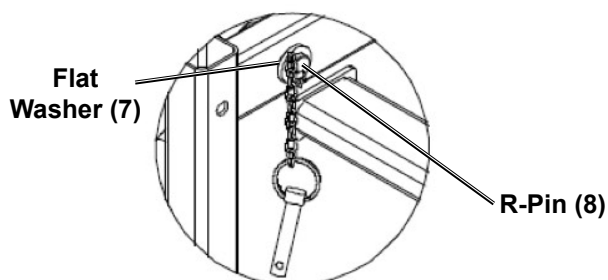

3. Lift the Foot Pedal and slide Cover Plate (9) into Base. Align the Cover Plate so that the hole in its leg aligns with the Base's holes.

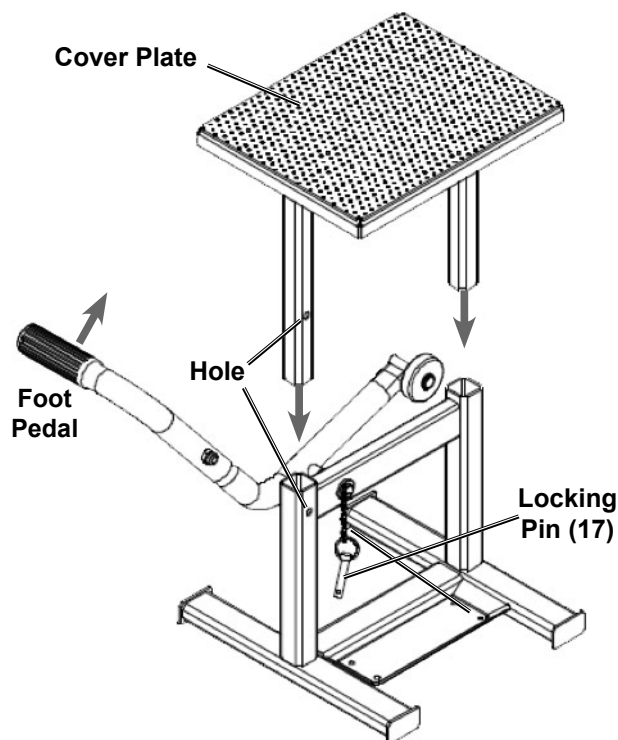

4. Before using the Bike Stand with a load, test the operation of the Pedal and Locking Pin (17) without any load.

Operating Instructions



Read the **ENTIRE IMPORTANT SAFETY INFORMATION** section at the beginning of this manual including all text under subheadings therein before set up or use of this product.

1. Locate Stand on hard, flat, and level surface able to withstand load without deforming.

WARNING! Confirm that **Locking Pin** is in place before attaching load. Do not use if **Locking Pin** is missing, bent, or damaged.

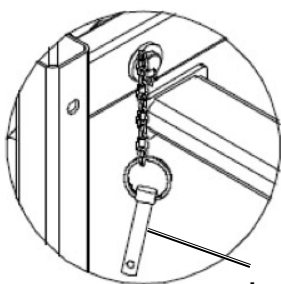

Locking Pin
hanging from Base

2. Center the dirt bike over the Saddle and **secure to Saddle with tie-down strap (sold separately) before lifting.**
3. Using second person to stabilize load, slowly raise Saddle by depressing the Pedal with your foot. Raise the Saddle until the hole in its side leg lines up with the hole in the Base side leg.
4. Insert the Locking Pin **fully through** the Saddle and Base holes to secure the Stand in the raised position.

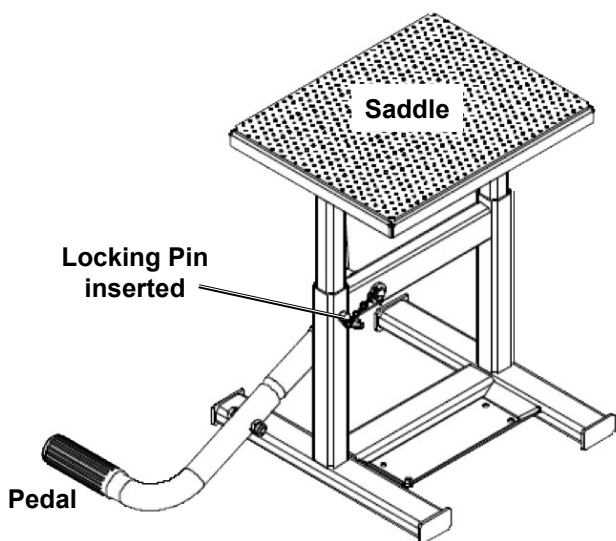

5. Remove tools from under stand before lowering.
6. To lower Saddle, use a second person to assist in removing the dirt bike from the Bike Stand.
 - a. Place foot on Pedal and lightly press while sliding out the Locking Pin.
 - b. Keep foot on Pedal and, once Locking Pin is out and area is clear, use the Pedal to smoothly lower Saddle.
7. Clean Stand after use, then store indoors out of children's reach.



Procedures not specifically explained in this manual must be performed only by a qualified technician.

WARNING

TO PREVENT SERIOUS INJURY FROM TOOL FAILURE:

Do not use damaged equipment. If abnormal noise or vibration occurs, have the problem corrected before further use.

Cleaning and Maintenance

1. **BEFORE EACH USE**, inspect the general condition of the tool. Check for loose screws, misalignment or binding of moving parts, cracked or broken parts, and any other condition that may affect its safe operation.
2. **AFTER USE**, clean external surfaces of the tool with clean cloth.

PLEASE READ THE FOLLOWING CAREFULLY

THE MANUFACTURER AND/OR DISTRIBUTOR HAS PROVIDED THE PARTS LIST AND ASSEMBLY DIAGRAM IN THIS DOCUMENT AS A REFERENCE TOOL ONLY. NEITHER THE MANUFACTURER OR DISTRIBUTOR MAKES ANY REPRESENTATION OR WARRANTY OF ANY KIND TO THE BUYER THAT HE OR SHE IS QUALIFIED TO MAKE ANY REPAIRS TO THE PRODUCT, OR THAT HE OR SHE IS QUALIFIED TO REPLACE ANY PARTS OF THE PRODUCT. IN FACT, THE MANUFACTURER AND/OR DISTRIBUTOR EXPRESSLY STATES THAT ALL REPAIRS AND PARTS REPLACEMENTS SHOULD BE UNDERTAKEN BY CERTIFIED AND LICENSED TECHNICIANS, AND NOT BY THE BUYER. THE BUYER ASSUMES ALL RISK AND LIABILITY ARISING OUT OF HIS OR HER REPAIRS TO THE ORIGINAL PRODUCT OR REPLACEMENT PARTS THERETO, OR ARISING OUT OF HIS OR HER INSTALLATION OF REPLACEMENT PARTS THERETO.

Parts List and Assembly Diagram

Part	Description	Qty.
1	Rubber Sleeve	1
2	Lower Pedal	1
3	Rectangular Plug	4
4	Base	1
5	Retaining Ring	2
6	Roller	1
7	Flat Washer	1
8	R-pin	1
9	Cover Plate	1

Part	Description	Qty.
10	Upper Pedal	1
11	Rubber Plate	1
12	Flat Washer	1
13	Nut	1
14	Bolt	1
15	Chain	1
16	Key Ring	1
17	Locking Pin	1

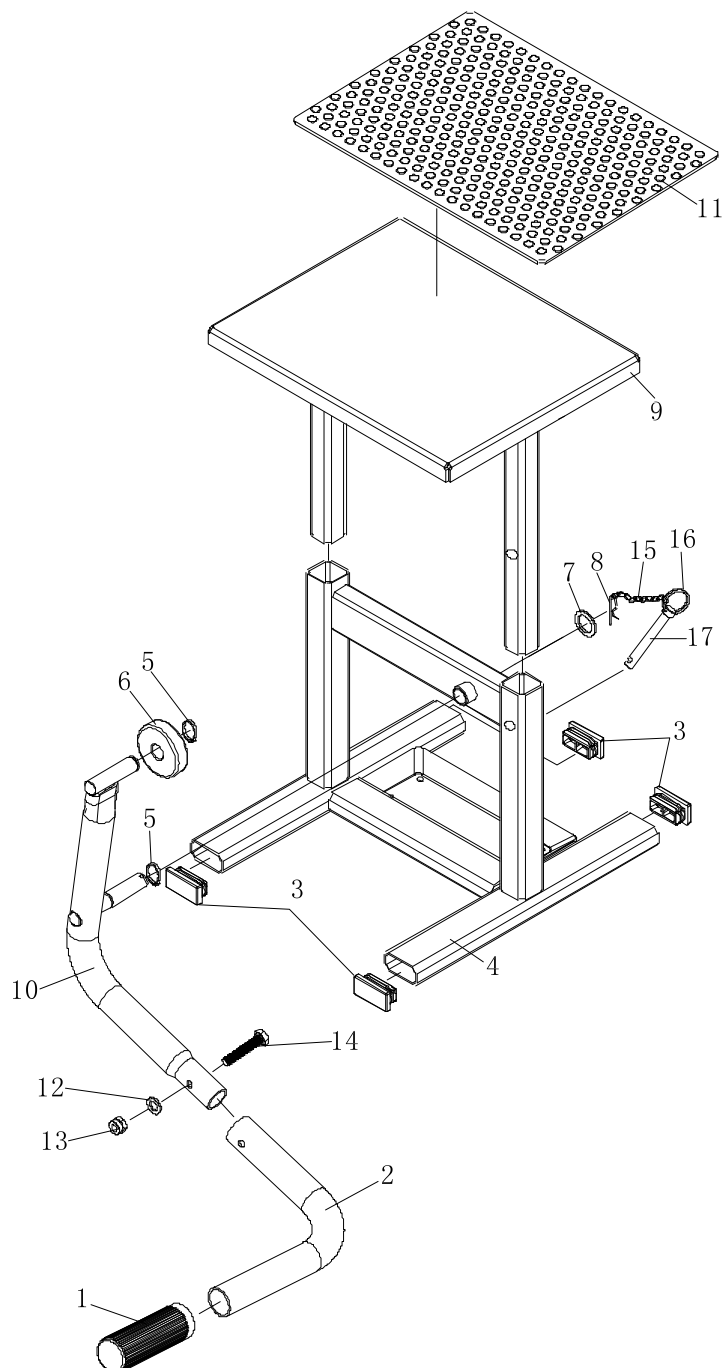

Record Product's Serial Number Here: _____

Note: If product has no serial number, record month and year of purchase instead.

Note: Some parts are listed and shown for illustration purposes only, and are not available individually as replacement parts.

Limited 90 Day Warranty

Harbor Freight Tools Co. makes every effort to assure that its products meet high quality and durability standards, and warrants to the original purchaser that this product is free from defects in materials and workmanship for the period of 90 days from the date of purchase. This warranty does not apply to damage due directly or indirectly, to misuse, abuse, negligence or accidents, repairs or alterations outside our facilities, criminal activity, improper installation, normal wear and tear, or to lack of maintenance. We shall in no event be liable for death, injuries to persons or property, or for incidental, contingent, special or consequential damages arising from the use of our product. Some states do not allow the exclusion or limitation of incidental or consequential damages, so the above limitation of exclusion may not apply to you. THIS WARRANTY IS EXPRESSLY IN LIEU OF ALL OTHER WARRANTIES, EXPRESS OR IMPLIED, INCLUDING THE WARRANTIES OF MERCHANTABILITY AND FITNESS.

To take advantage of this warranty, the product or part must be returned to us with transportation charges prepaid. Proof of purchase date and an explanation of the complaint must accompany the merchandise. If our inspection verifies the defect, we will either repair or replace the product at our election or we may elect to refund the purchase price if we cannot readily and quickly provide you with a replacement. We will return repaired products at our expense, but if we determine there is no defect, or that the defect resulted from causes not within the scope of our warranty, then you must bear the cost of returning the product.

This warranty gives you specific legal rights and you may also have other rights which vary from state to state.

PITTSBURGH[®] MOTORCYCLE

26541 Agoura Road • Calabasas, CA 91302 • 1-888-866-5797