

Owner's Manual & Safety Instructions

Save This Manual Keep this manual for the safety warnings and precautions, assembly, operating, inspection, maintenance and cleaning procedures. Write the product's serial number in the back of the manual near the assembly diagram (or month and year of purchase if product has no number). Keep this manual and the receipt in a safe and dry place for future reference.

21g

MADDOXTM

SUPERIOR AUTOMOTIVE TOOLS

MH-DCT19

Basic Fuel Injection Service Kit



Visit our website at: <http://www.harborfreight.com>
Email our technical support at: productsupport@harborfreight.com

64939

When unpacking, make sure that the product is intact and undamaged. If any parts are missing or broken, please call 1-888-866-5797 as soon as possible.

Copyright© 2021 by Harbor Freight Tools®. All rights reserved.
No portion of this manual or any artwork contained herein may be reproduced in any shape or form without the express written consent of Harbor Freight Tools. Diagrams within this manual may not be drawn proportionally. Due to continuing improvements, actual product may differ slightly from the product described herein. Tools required for assembly and service may not be included.

⚠WARNING

Read this material before using this product.
Failure to do so can result in serious injury.
SAVE THIS MANUAL.

Pressure Gauge

0~100 PSI, 0~700 kPa

IMPORTANT SAFETY INFORMATION

1. Do not use on diesel engines.
2. Stop engine, loosen gas cap and relieve fuel pump pressure (see service manual) before opening fuel line. Do not change fittings with engine running or fuel line pressurized.
3. Do not overtighten fasteners. Brass fasteners or hollow fasteners may be easily damaged by overtightening. Tighten enough to get a good seal.
4. Before testing fuel system, verify all connections are tight to eliminate leaking.
5. Gasoline is highly flammable. Do not smoke, or test near an ignition source. Do not allow gasoline to come in contact with the hot manifolds or other engine components. If additional lighting is required, use only an explosion-proof drop-light.
6. Do not drive the vehicle while under test.
7. Before testing, review and follow instructions from the vehicle manufacturer's service manual.
8. After testing, turn engine off and depressurize system before removing test components. Place absorbing cloths around fittings before disconnecting. Wipe up any spilled fuel immediately. Place cloths in a fireproof container.
9. Clean all testing components of residual fuel before storing.
10. Wear ANSI-approved safety goggles and heavy-duty work gloves during setup and use.
11. This product is not a toy. Do not allow children to play with or near this item.
12. Use as intended only.
13. Inspect before every use; do not use if parts are loose or damaged.
14. Perform service in a well-ventilated location. Not only are gasoline fumes flammable, but carbon monoxide is produced by a running engine. This is a deadly gas that you cannot see or smell.
15. Maintain product labels and nameplates. These carry important safety information. If unreadable or missing, contact Harbor Freight Tools for a replacement.
16. The warnings, precautions, and instructions discussed in this instruction manual cannot cover all possible conditions and situations that may occur. It must be understood by the operator that common sense and caution are factors which cannot be built into this product, but must be supplied by the operator.

MADDOX™
SUPERIOR AUTOMOTIVE TOOLS

Features

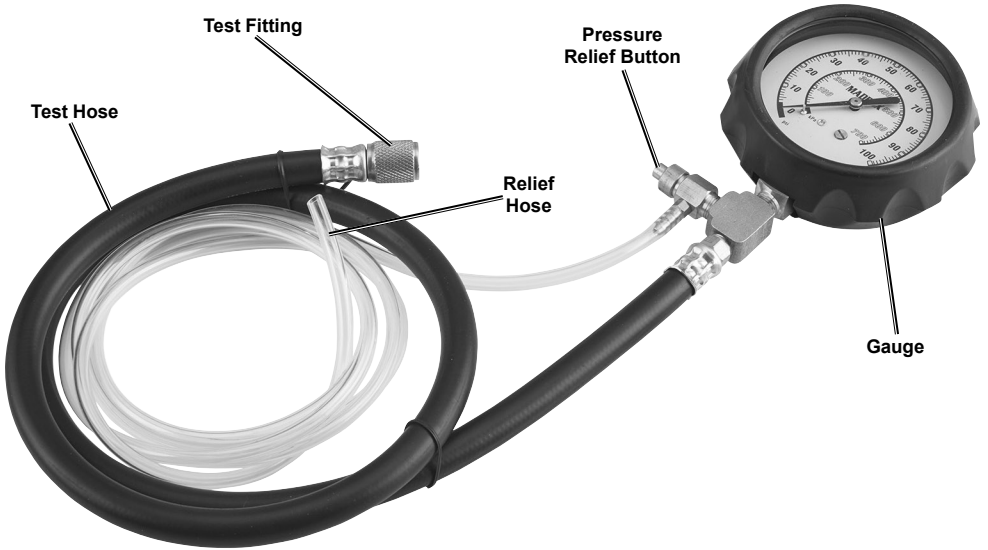

MADDOX™
SUPERIOR AUTOMOTIVE TOOLS

Operating Instructions



Read the **ENTIRE IMPORTANT SAFETY INFORMATION** section at the beginning of this document including all text under subheadings therein before set up or use of this product.

Note: Tools referenced in these instructions are sold separately.

1. WARNING! TO PREVENT SERIOUS INJURY: Before testing:

- a. **Make sure the area is well-ventilated and free of ignition sources and flammable materials.**
 - b. Place a dry chemical (class B) fire extinguisher nearby.
 - c. Turn ignition off.
 - d. Inspect engine, vacuum, fuel and electrical system for additional problems and broken or worn components. Repair problems before proceeding, particularly problems that may ignite spilled fuel or allow a fuel leak.
 - e. Make sure fuel tank is full and starting battery is charged.
 - f. If the vehicle has an fuel shutoff inertia switch, confirm it has not been tripped. Inertia switches are found on certain Ford/Lincoln/Mercury vehicles.
2. Lay shop rags down to collect any spilled fuel. A small amount of fuel will leak even during a correct connection. Have plenty of extra shop rags available in the event of any additional unexpected leak.
3. Find the correct connection method for your vehicle. Refer to service instructions as needed.

A. Vehicles with a test port:

- a. Remove cap from test port.
- b. (Ford vehicles only) Thread Ford Test Adapter (7) onto the end of the test port. Finger tighten securely.
- c. Connect the Test Fitting to the test port/Adapter securely.

B. GM TBI vehicles without a test port:

- a. Disable all fuel pumps and properly release pressure from the fuel lines as needed according to the vehicle's service instructions.
- b. Be prepared to catch any excess fuel and disconnect the fuel line at the point directed in the service instructions.
- c. Attach the GM TBI Adapter (3) to the fuel line and the port it was previously attached to.
- d. Finger-tighten both connections securely, then turn one-half turn farther using a wrench.
- e. Attach the Test Fitting to the remaining fitting on the GM TBI Adapter.

C. Vehicles with a banjo bolt connection:

- a. Disable all fuel pumps and properly release pressure from the fuel lines as needed according to the vehicle's service instructions.
- b. Be prepared to catch any excess fuel and remove banjo bolt connector at point directed in the vehicle's service instructions.
- c. Place the stock banjo bolt and washers in a safe location. They will be needed for reassembly.
- d. Replace the stock banjo bolt with a correctly-sized Banjo Bolt Adapter (4-6) from this kit. Use one washer from the Banjo Bolt Adapter above the banjo fitting, and one below it.
WARNING! TO PREVENT SERIOUS INJURY: If none of the Banjo Bolt Adapters in this kit fit securely, then this kit is not compatible and should not be used.
- e. Tighten Banjo Bolt Adapter finger tight, then use a wrench to gently turn it snug.
- f. Attach the Test Fitting to the remaining fitting on the Banjo Bolt Adapter.

D. Vehicles with rubber hose connections:

- a. Disable all fuel pumps and properly release pressure from the fuel lines as needed according to the vehicle's service instructions.
- b. Be prepared to catch any excess fuel and disconnect fuel hose at point directed in the vehicle's service instructions.
- c. Determine size of fuel hose, either 1/4" or 3/8" inner diameter. Connect the appropriate Hose (8,9) from the kit to one of the aluminum fittings on the Hose Manifold (2). If using the 3/8" Hose, slide it all the way onto the inner part of the Hose Manifold. Secure the Hose using a Hose Clamp (10).
- d. Slide a Hose Clamp over the end of the vehicle's fuel hose. Connect the vehicle's fuel hose to the other aluminum fitting on the Hose Manifold. If it is a 3/8" hose, slide it all the way onto the inner part of the Hose Manifold. Secure it using a Hose Clamp.
- e. Slide a Hose Clamp over the end of the Hose that is attached to the Hose Manifold. Connect this Hose to the vehicle's fuel connector where the fuel hose used to be connected. Secure it using a Hose Clamp.
- f. Tighten all Hose Clamps securely using a screwdriver.
- g. Attach the Test Fitting to the remaining fitting on the Hose Manifold.

WARNING! TO PREVENT SERIOUS INJURY AND DEATH FROM FIRE, do not proceed with testing unless all connections are the correct size and seal completely.

4. Secure end of clear relief hose inside an appropriate fuel collection container in a safe place that will not be damaged, heated, or knocked over.
5. If fuel pumps were disabled for connecting the kit, re-enable them.

Note: This is a generic procedure. Follow vehicle service instructions for correct test procedure.

6. Turn ignition to on position.

7. Turn off all accessories, such as radio, air conditioning, etc.
8. Listen that fuel pump starts briefly.
9. Check for leaks. If a leak is found, turn ignition off, then clean up and fix any leaks before proceeding.
10. Turn ignition off, then back on to cycle fuel pump again. Continue cycling fuel pump to ensure pressure builds to manufacturer's specification.
11. Again check for leaks. If a leak is found, turn ignition off, then clean up and fix any leaks before proceeding.
12. Perform any additional idle or other test measurements as directed in vehicle's service instructions.
13. Turn ignition off.
14. Make sure end of clear relief hose is still secured inside an appropriate fuel collection container. Then press and hold the pressure relief button until the pressure gauge reads 0.
15. Allow remaining fuel to drain out of relief hose, then remove it from the fuel collection container and seal that container.
16. Use shop rags to catch any spilled fuel while disconnecting the kit from the fuel system. If a banjo bolt connection was used, put the stock banjo bolt and washers back in place exactly as they were before the test. Tighten all connections according to manufacturer specifications.

WARNING! TO PREVENT SERIOUS INJURY AND DEATH FROM FIRE, place all shop rags and other materials that contain fuel or fuel vapor into an approved, ignition-resistant safety oily waste can or dispose of them properly.

17. Allow kit to dry completely in an area away from ignition sources and other flammable materials before storing it.

MADDOX™
SUPERIOR AUTOMOTIVE TOOLS

User-Maintenance Instructions



Procedures not specifically explained in this manual must be performed only by a qualified technician.

!WARNING

TO PREVENT SERIOUS INJURY AND DEATH FROM FIRE:
Do not use damaged equipment. If any damage or wear is found, have the problem corrected before further use.

Cleaning, Maintenance, and Lubrication

1. **BEFORE EACH USE**, inspect the general condition of the tool. Check for:
 - loose hardware or housing,
 - misalignment or binding of moving parts,
 - worn or cracked hoses,
 - deformed fittings,
 - cracked or broken parts, and
 - any other condition that may affect its safe operation.
2. Before storage, make sure all fuel has been drained from all hoses and fittings and all fuel vapors have dissipated. Keep all flammable materials and ignition sources away from this kit.

Parts List and Diagram

Part	Description	Qty
1	Pressure Gauge Assembly	1
2	Hose Manifold	1
3	GM TBI Adapter	1
4	Banjo Bolt Adapter M12*1.5	1
5	Banjo Bolt Adapter M12*1.25	1
6	Banjo Bolt Adapter M8*1.0	1
7	Ford Test Adapter	1
8	5/16" Hose	1
9	1/4" Hose	1
10	Hose Clamp	4
11	Repair Kit	1

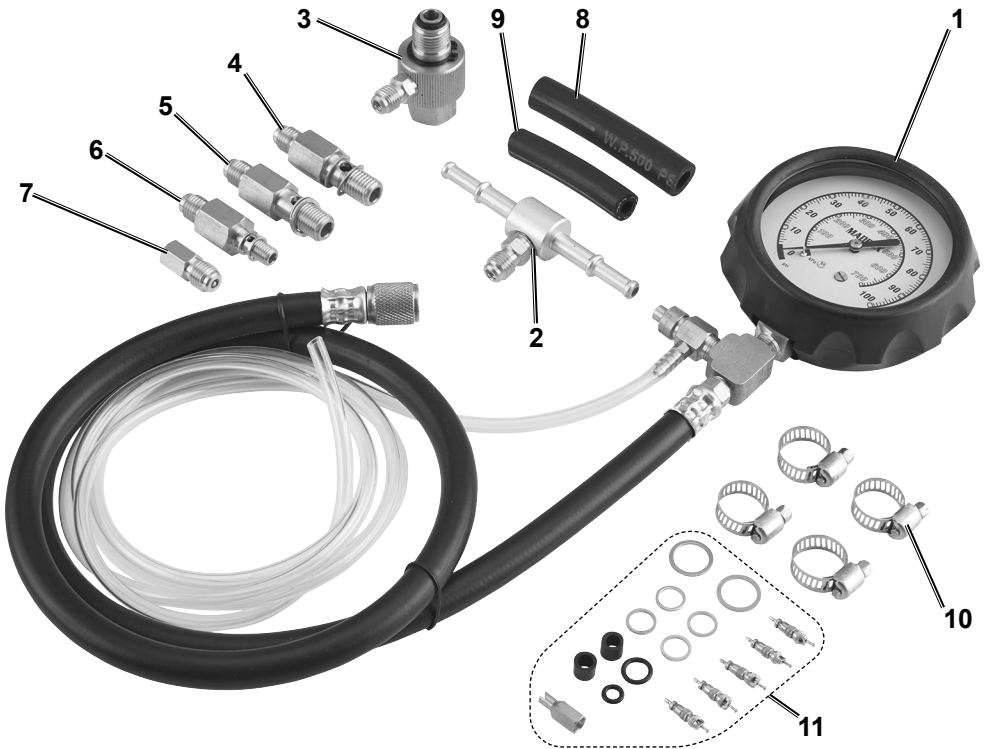

Record Product's Serial Number Here: _____

Note: If product has no serial number, record month and year of purchase instead.

Note: Some parts are listed and shown for illustration purposes only, and are not available individually as replacement parts. Specify UPC 193175446893 when ordering parts.

PLEASE READ THE FOLLOWING CAREFULLY

THE MANUFACTURER AND/OR DISTRIBUTOR HAS PROVIDED THE PARTS LIST AND ASSEMBLY DIAGRAM IN THIS DOCUMENT AS A REFERENCE TOOL ONLY. NEITHER THE MANUFACTURER OR DISTRIBUTOR MAKES ANY REPRESENTATION OR WARRANTY OF ANY KIND TO THE BUYER THAT HE OR SHE IS QUALIFIED TO MAKE ANY REPAIRS TO THE PRODUCT, OR THAT HE OR SHE IS QUALIFIED TO REPLACE ANY PARTS OF THE PRODUCT. IN FACT, THE MANUFACTURER AND/OR DISTRIBUTOR EXPRESSLY STATES THAT ALL REPAIRS AND PARTS REPLACEMENTS SHOULD BE UNDERTAKEN BY CERTIFIED AND LICENSED TECHNICIANS, AND NOT BY THE BUYER. THE BUYER ASSUMES ALL RISK AND LIABILITY ARISING OUT OF HIS OR HER REPAIRS TO THE ORIGINAL PRODUCT OR REPLACEMENT PARTS THERETO, OR ARISING OUT OF HIS OR HER INSTALLATION OF REPLACEMENT PARTS THERETO.

Limited 90 Day Warranty

Harbor Freight Tools Co. makes every effort to assure that its products meet high quality and durability standards, and warrants to the original purchaser that this product is free from defects in materials and workmanship for the period of 90 days from the date of purchase. This warranty does not apply to damage due directly or indirectly, to misuse, abuse, negligence or accidents, repairs or alterations outside our facilities, criminal activity, improper installation, normal wear and tear, or to lack of maintenance. We shall in no event be liable for death, injuries to persons or property, or for incidental, contingent, special or consequential damages arising from the use of our product. Some states do not allow the exclusion or limitation of incidental or consequential damages, so the above limitation of exclusion may not apply to you. THIS WARRANTY IS EXPRESSLY IN LIEU OF ALL OTHER WARRANTIES, EXPRESS OR IMPLIED, INCLUDING THE WARRANTIES OF MERCHANTABILITY AND FITNESS.

To take advantage of this warranty, the product or part must be returned to us with transportation charges prepaid. Proof of purchase date and an explanation of the complaint must accompany the merchandise. If our inspection verifies the defect, we will either repair or replace the product at our election or we may elect to refund the purchase price if we cannot readily and quickly provide you with a replacement. We will return repaired products at our expense, but if we determine there is no defect, or that the defect resulted from causes not within the scope of our warranty, then you must bear the cost of returning the product.

This warranty gives you specific legal rights and you may also have other rights which vary from state to state.

MADDOX™
SUPERIOR AUTOMOTIVE TOOLS

26541 Agoura Road • Calabasas, CA 91302 • 1-888-866-5797