

Owner's Manual & Safety Instructions

Save This Manual Keep this manual for the safety warnings and precautions, assembly, operating, inspection, maintenance and cleaning procedures. Write the product's serial number in the back of the manual near the assembly diagram (or month and year of purchase if product has no number). Keep this manual and the receipt in a safe and dry place for future reference.

24f

PITTSBURGH™

12 VOLT DIESEL TRANSFER PUMP



Item

66784

Visit our website at: <http://www.harborfreight.com>
Email our technical support at: productsupport@harborfreight.com

When unpacking, make sure that the product is intact and undamaged. If any parts are missing or broken, please call 1-888-866-5797 as soon as possible.

Copyright© 2024 by Harbor Freight Tools®. All rights reserved.
No portion of this manual or any artwork contained herein may be reproduced in any shape or form without the express written consent of Harbor Freight Tools. Diagrams within this manual may not be drawn proportionally. Due to continuing improvements, actual product may differ slightly from the product described herein.
Tools required for assembly and service may not be included.

⚠ WARNING





Read this material before using this product.
Failure to do so can result in serious injury.
SAVE THIS MANUAL.

Table of Contents

Safety	2	Maintenance	9
Specifications	6	Parts List and Diagram	10
Setup	7	Warranty	12
Operation.....	8		

PITTSBURGH™

WARNING SYMBOLS AND DEFINITIONS

	This is the safety alert symbol. It is used to alert you to potential personal injury hazards. Obey all safety messages that follow this symbol to avoid possible injury or death.
	Indicates a hazardous situation which, if not avoided, will result in death or serious injury.
	Indicates a hazardous situation which, if not avoided, could result in death or serious injury.
	Indicates a hazardous situation which, if not avoided, could result in minor or moderate injury.
	Addresses practices not related to personal injury.

IMPORTANT SAFETY INFORMATION

General Safety Warnings

WARNING

Read all safety warnings and all instructions.

Failure to follow the warnings and instructions may result in electric shock, fire and/or serious injury.

Save all warnings and instructions for future reference.

The warnings, precautions, and instructions discussed in this instruction manual cannot cover all possible conditions and situations that may occur. It must be understood by the operator that common sense and caution are factors which cannot be built into this product, but must be supplied by the operator.

Work Area Safety

- Keep work area clean and well lit.** *Cluttered or dark areas increase the risks of electric shock, fire, and injury to persons.*
- Do not operate pumps in explosive atmospheres, such as in the presence of flammable liquids, gases or dust.** *Pumps create sparks which may ignite the dust or fumes.*
- Keep bystanders, children, and visitors away while operating the pump.** *Distractions are able to result in the loss of control of the pump.*

Electrical Safety

1. **Do not expose pumps to rain or wet conditions.** *Water entering a pump will increase the risk of electric shock.*
2. **Do not abuse the Power Cables. Never use the cables for carrying or pulling the pump. Keep cables away from heat, oil, sharp edges or moving parts.** *Damaged or entangled cables increase the risk of electric shock.*

Personal Safety

1. **Stay alert, watch what you are doing and use common sense when operating a pump. Do not use a pump while you are tired or under the influence of drugs, alcohol or medication.** *A moment of inattention while operating pumps may result in serious personal injury.*
2. **Prevent unintentional starting.** *Ensure the switch is in the off-position before connecting to the power supply.*
3. **Do not overreach. Keep proper footing and balance at all times.** *Proper footing and balance enables better control of the pump in unexpected situations.*
4. **Use safety equipment.** *A dust mask, non-skid safety shoes and a hard hat must be used for the applicable conditions.*
5. **Dress properly. Do not wear loose clothing or jewelry. Keep your hair, clothing and gloves away from moving parts.** *Loose clothes, jewelry or long hair can be caught in moving parts.*
6. **Wear ANSI-approved safety goggles during setup and use.**

Pump Use and Care

1. **Do not force the pump. use the correct pump for your application.** *The correct pump will do the job better and safer at the rate for which it was designed.*
2. **Do not use the pump if the switch does not turn it on and off.** *Any pump that cannot be controlled with the switch is dangerous and must be repaired.*
3. **Disconnect the Cables from the power supply before making any adjustments, changing accessories, or storing pumps.** *Such preventive safety measures reduce the risk of starting the pump accidentally.*
4. **Store idle pumps out of the reach of children and do not allow persons unfamiliar with the pump or these instructions to operate the pump.** *Pumps are dangerous in the hands of untrained users.*
5. **Maintain pumps. Check for misalignment or binding of moving parts, breakage of parts and any other condition that may affect the pump's operation. If damaged, have the pump repaired before use.** *Many accidents are caused by poorly maintained pumps.*
6. **Use the pump, accessories and pump bits etc. in accordance with these instructions, taking into account the working conditions and the work to be performed.** *Use of the pump for operations different from those intended could result in a hazardous situation.*

Battery Precautions

Under abusive conditions, liquid may be ejected from the battery. avoid contact. If contact accidentally occurs, flush with water. If liquid contacts eyes, additionally seek medical help. *Liquid ejected from the battery may cause irritation or burns.*

Service

Pump service must be performed only by qualified repair personnel, using only identical replacement parts. *This will ensure that the safety of the pump is maintained.*

Specific Safety Instructions

SAFETY

1. **This Pump is designed for use with diesel fuel or kerosene only. Not for use with fluids that have a flash point below 100° F (i.e., gasoline, alcohol).**
2. **Never smoke near the Pump or use the Pump near an open flame.**
3. **Do not use for fluid transfer into or from aircraft.**
4. **This product is not designed for use with medical products, water, or fluids for human consumption.**
5. **Anchor the barrel or tank (not included) to prevent tipping.**
6. **Do not use while on a motorized vehicle while the engine is running.**
7. Avoid unintentional starting. Prepare to begin work before turning on the Pump.
8. When using a handheld pump, maintain a firm grip on the pump with both hands to resist starting torque.
9. Do not leave the Pump unattended when it is connected to a power supply. Turn off the pump, and disconnect it from its power supply before leaving.
10. This product is not a toy. Keep it out of reach of children.
11. Maintain labels and nameplates on the Pump. These carry important safety information. If unreadable or missing, contact Harbor Freight Tools for a replacement.
12. People with pacemakers should consult their physician(s) before use. Electromagnetic fields in close proximity to heart pacemaker could cause pacemaker interference or pacemaker failure. In addition, people with pacemakers should:
 - Avoid operating alone.
 - Do not use with power switch locked on.
 - Properly maintain and inspect to avoid electrical shock.
13. The warnings, precautions, and instructions discussed in this instruction manual cannot cover all possible conditions and situations that may occur. It must be understood by the operator that common sense and caution are factors which cannot be built into this product, but must be supplied by the operator.

SETUP

OPERATION





MAINTENANCE



SAVE THESE INSTRUCTIONS.

Symbology

	Double Insulated
V	Volts
~	Alternating Current
A	Amperes
n_0 xxxx/min.	No Load Revolutions per Minute (RPM)

	WARNING marking concerning Risk of Eye Injury. Wear ANSI-approved safety goggles with side shields.
	Read the manual before set-up and/or use.
	WARNING marking concerning Risk of Fire. Do not cover ventilation ducts. Keep flammable objects away.
	WARNING marking concerning Risk of Electric Shock. Properly connect power cord to appropriate outlet.

Specifications

Product Applications	Only use with diesel fuel or kerosene. Do not use with gasoline, alcohol, water, corrosive chemicals, solvents, or liquids that have a flash point below 100°F.
Electrical Input	12VDC / 13.5A
Fuse	25A (included)
Motor	30 Minute Duty Cycle* 2800RPM
Pump	Self-Priming, Volumetric, Rotating Vane, with Bypass Valve Inlet/Outlet: 3/4" Female NPT Lift: 6.6 Feet Flow Rate: 10GPM
Operating Conditions	-4° – 140°F up to 90% Relative Humidity
Hose Size	3/4" I.D., 1-1/4" O.D., 13' Long
Thermal Overload Protection	Yes

*Duty Cycle (Duration of Use)

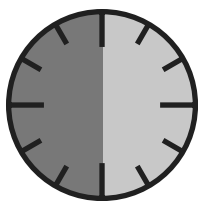

30 Minute Duty Cycle
30 minutes pumping
followed by
at least 30 minutes of rest

Avoid damage to the Pump by not pumping for more than the prescribed duty cycle time. The Duty Cycle defines the number of minutes, within a one hour period, during which a given pump can pump without overheating. For example, this Pump with a 30 minute duty cycle must be allowed to rest for at least 30 minutes after every 30 minutes of use. Failure to carefully observe duty cycle limitations can easily over-stress a pump contributing to premature pump failure.

This pump has an internal thermal protection system to help prevent this sort of over-stress. When the unit overheats, it automatically shuts down, then it automatically begins pumping again after cooling off. When the pump can be used again, use shorter pumping periods and longer rest periods to prevent needless wear.

PITTSBURGH[™]

Setup - Before Use:



Read the **ENTIRE IMPORTANT SAFETY INFORMATION** section at the beginning of this manual including all text under subheadings therein before set up or use of this product.

WARNING

TO PREVENT SERIOUS INJURY FROM ACCIDENTAL OPERATION:
Disconnect the Pump from its power supply before assembly/installation.

Note: For additional information regarding the parts listed in the following pages, refer to *Parts List and Diagram* on page 10.

Assembly

Note: Thread seal tape mentioned hereafter is not supplied with this pump.

1. Cut the supplied hose, into two lengths, keeping in mind that the suction end should be long enough to reach within one inch of the supply tank bottom and at the same time to be long enough so that the Pump could be located at a point away from the supply tank opening.

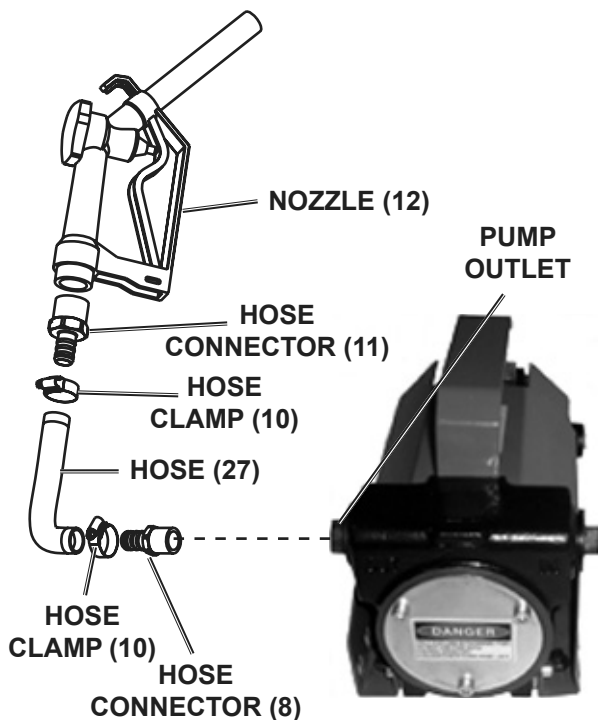

2. Apply pipe thread seal tape to the threads of one 3/4" Hose Connector (8) and screw it firmly into the Pump outlet.
3. Apply pipe thread seal tape to the threads of the 1" Hose Connector (11) and screw it firmly into the Nozzle (12).

Note: The included Hose (27) can be cut to provide an inlet and outlet hose, or another hose of the same size can be purchased as needed.
Any hose used with this product must be designed for use with the liquid being pumped.

4. Slide two Hose Clamps (10) onto the discharge Hose (27). Twist each end of the hose over the two barbed fittings and push forward until the hose ends presses firmly over the O-rings and against the fitting shoulder.
5. Slide the Hose Clamps to within 3/8" of the fitting shoulder and tighten the screws, securing the hose onto the fittings.
6. Apply pipe thread seal tape to the threads of one 3/4" Hose Connector (8) and screw it firmly into the Pump inlet.

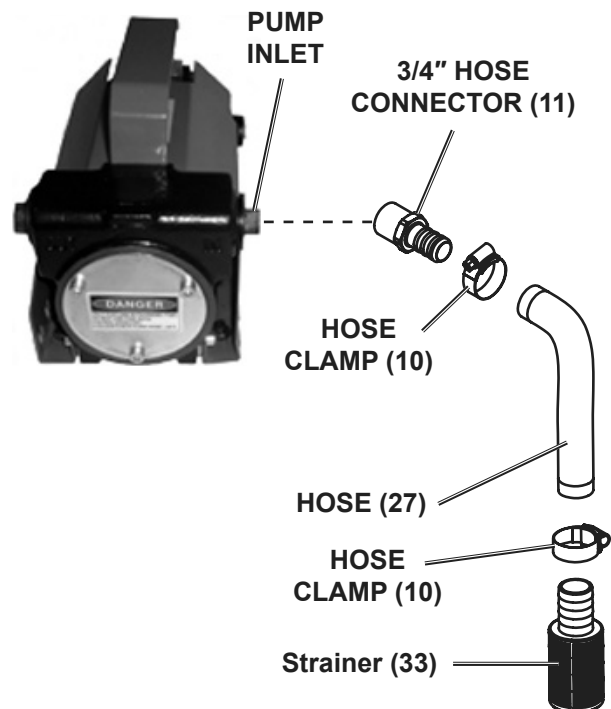

7. Slide two Hose Clamps (10) onto the inlet Hose (27). Twist one end of the hose over the pump inlet barbed fitting and the other end over the barbed fitting on the strainer. Push the hose forward until the hose ends presses firmly over the O-rings and against the fitting shoulders.
8. Slide the Hose Clamps to within 3/8" of the fitting shoulder and tighten the screws, securing the hose onto the fittings.

Operating Instructions



Read the **ENTIRE IMPORTANT SAFETY INFORMATION** section at the beginning of this manual including all text under subheadings therein before set up or use of this product. Inspect pump before use, looking for damaged, loose, and missing parts. If any problems are found, do not use pump until repaired.

Pump Set Up

⚠️ WARNING

TO PREVENT SERIOUS INJURY FROM ACCIDENTAL OPERATION:
Disconnect the Pump from its 12 volt power source before performing any inspection, maintenance, or cleaning procedures.

1. Designate a work area that is clean and well-lit. The work area must not allow access by children or pets to prevent distraction or injury.
2. Route the Power Cables along a safe route to reach the work area without creating a tripping hazard or exposing the cables to possible damage. The cables must reach the work area with enough extra length to allow free movement while working.
3. There must not be hazardous objects, such as utility lines or foreign objects, nearby that will present a hazard while working.
4. Have rags nearby to clean up any fuel spills.
5. Have multiple fully charged ABC fire extinguishers nearby in case of fire.

General Operating Instructions

1. Connect the Cables with Clamps to a 12 volt power supply (such as a battery, not included). Connect the RED Clamp to the Positive (+) terminal and the BLACK Clamp to the Negative (-) terminal.
2. Insert the Nozzle into the destination tank.
3. Insert the Hose with its Strainer into the fuel supply tank. Immerse the Strainer in the fuel fully.
4. Press the Power Switch to start the Pump.
5. Squeeze trigger of the Nozzle to discharge fuel into the destination tank. Hold the Nozzle firmly during the fuel transfer.
6. To reduce hand fatigue during extended pumping, lock the Trigger in one of the two positions by lifting and positioning the spring loaded trigger lock into one of the two recessed steps under the trigger. Ease back on trigger to lock it in place. To stop pumping, pull slightly on the trigger to release the lock.
7. When the fuel has been transferred, release pressure on the Nozzle Trigger. When fuel stops flowing, turn off the Pump.
8. Disconnect the Cables with Clamps black first, then red, from the 12 volt power supply.
9. Remove the Nozzle from the destination tank and place in a secure location.
10. Remove the Hose with its Strainer from the fuel supply tank, allowing fuel to drain out of the Hose before removing it.
11. Cap both supply and the destination tanks to prevent fuel spills.
12. Clean and dry all exterior parts of the Pump Body, Hose, Nozzle, and Cables with Clamps.
13. Store the Pump indoors and out of reach of children and other unauthorized persons.

Maintenance and Servicing



Procedures not specifically explained in this manual must be performed only by a qualified technician.

!WARNING

TO PREVENT SERIOUS INJURY FROM ACCIDENTAL OPERATION:
Disconnect the Pump from its 12 volt power source before performing any inspection, maintenance, or cleaning procedures.

TO PREVENT SERIOUS INJURY FROM PUMP FAILURE:
Do not use damaged equipment. If abnormal noise, vibration, or leaking air occurs, have the problem corrected before further use.

Cleaning, Maintenance, and Lubrication

- BEFORE EACH USE**, inspect the general condition of the pump. Check for:
 - loose hardware,
 - misalignment or binding of moving parts,
 - damaged cord/electrical wiring,
 - cracked or broken parts, and
 - any other condition that may affect its safe operation.
- AFTER USE**, wipe external surfaces of the pump with clean cloth.
- TO REPLACE THE FUSE:**
 - Disconnect the Cables from the 12V power source.
 - Open the Fuse Holder on the Cable.
 - Remove the Fuse by pulling it straight out of the Fuse Holder. Then press in a new Fuse of the same type, size, and rating (25A).
 - Close the Fuse Holder on the Cable.

Troubleshooting

Problem	Possible Causes	Likely Solutions
Pump will not start.	<ol style="list-style-type: none">Battery is dead or discharged.Clamps are not properly connected.Fuse burned out.	<ol style="list-style-type: none">Check battery power.Make sure clamps are securely connected.Replace with new fuse.
Pump will not operate or pumps fuel in wrong direction.	Clamps are connected in wrong polarity.	Reverse clamps. (Red clamp on positive (+) terminal. Black clamp on negative (-) terminal).
Poor fuel transfer.	<ol style="list-style-type: none">Intake hose is not submerged in fuel or supply tank is low or empty.Clogged Strainer.Kinked hoses.Hoses are leaking.Hoses or handle is clogged.	<ol style="list-style-type: none">Check intake hose and supply tank.Wash/replace Strainer.Straighten Hose.Check hoses for leaks and repair or replace.Check and clean hoses and handle.



Follow all safety precautions whenever diagnosing or servicing the tool.
Disconnect power supply before service.

PLEASE READ THE FOLLOWING CAREFULLY

THE MANUFACTURER AND/OR DISTRIBUTOR HAS PROVIDED THE PARTS LIST AND ASSEMBLY DIAGRAM IN THIS MANUAL AS A REFERENCE TOOL ONLY. NEITHER THE MANUFACTURER OR DISTRIBUTOR MAKES ANY REPRESENTATION OR WARRANTY OF ANY KIND TO THE BUYER THAT HE OR SHE IS QUALIFIED TO MAKE ANY REPAIRS TO THE PRODUCT, OR THAT HE OR SHE IS QUALIFIED TO REPLACE ANY PARTS OF THE PRODUCT. IN FACT, THE MANUFACTURER AND/OR DISTRIBUTOR EXPRESSLY STATES THAT ALL REPAIRS AND PARTS REPLACEMENTS SHOULD BE UNDERTAKEN BY CERTIFIED AND LICENSED TECHNICIANS, AND NOT BY THE BUYER. THE BUYER ASSUMES ALL RISK AND LIABILITY ARISING OUT OF HIS OR HER REPAIRS TO THE ORIGINAL PRODUCT OR REPLACEMENT PARTS THERETO, OR ARISING OUT OF HIS OR HER INSTALLATION OF REPLACEMENT PARTS THERETO.

Parts List

Part	Description	Qty
1	Screw (M5x10)	8
2	Front Cover	1
3	O-Ring	1
4	Rotor	1
5	Blade	5
6	Pump Body	1
7	Bypass Valve	1
8	3/4" Male Hose Connector	2
9	Handle	1
10	Hose Clamp	4
11	1" Hose Connector	1
12	Nozzle	1
13	Fuse (25A)	1
15	Power Switch	1
16	Cables with Clamps and Fuse Holder	1

Part	Description	Qty
17	Terminal Board	1
18	Screw (M4x15)	2
19	Compression Nut	1
20	Tapered Ring	1
21	Nut (M5)	2
22	Terminal	2
23	12VDC Motor	1
24	Bearing	2
25	Spring Collar	1
26	Seal	1
27	Hose	1
30	Bypass Spring	1
31	Base	1
32	Key	1
33	Strainer	1

Record Product's Serial Number Here: _____

Note: If product has no serial number, record month and year of purchase instead.

Note: Some parts are listed and shown for illustration purposes only, and are not available individually as replacement parts. Reference UPC 193175542670.

Assembly Diagram

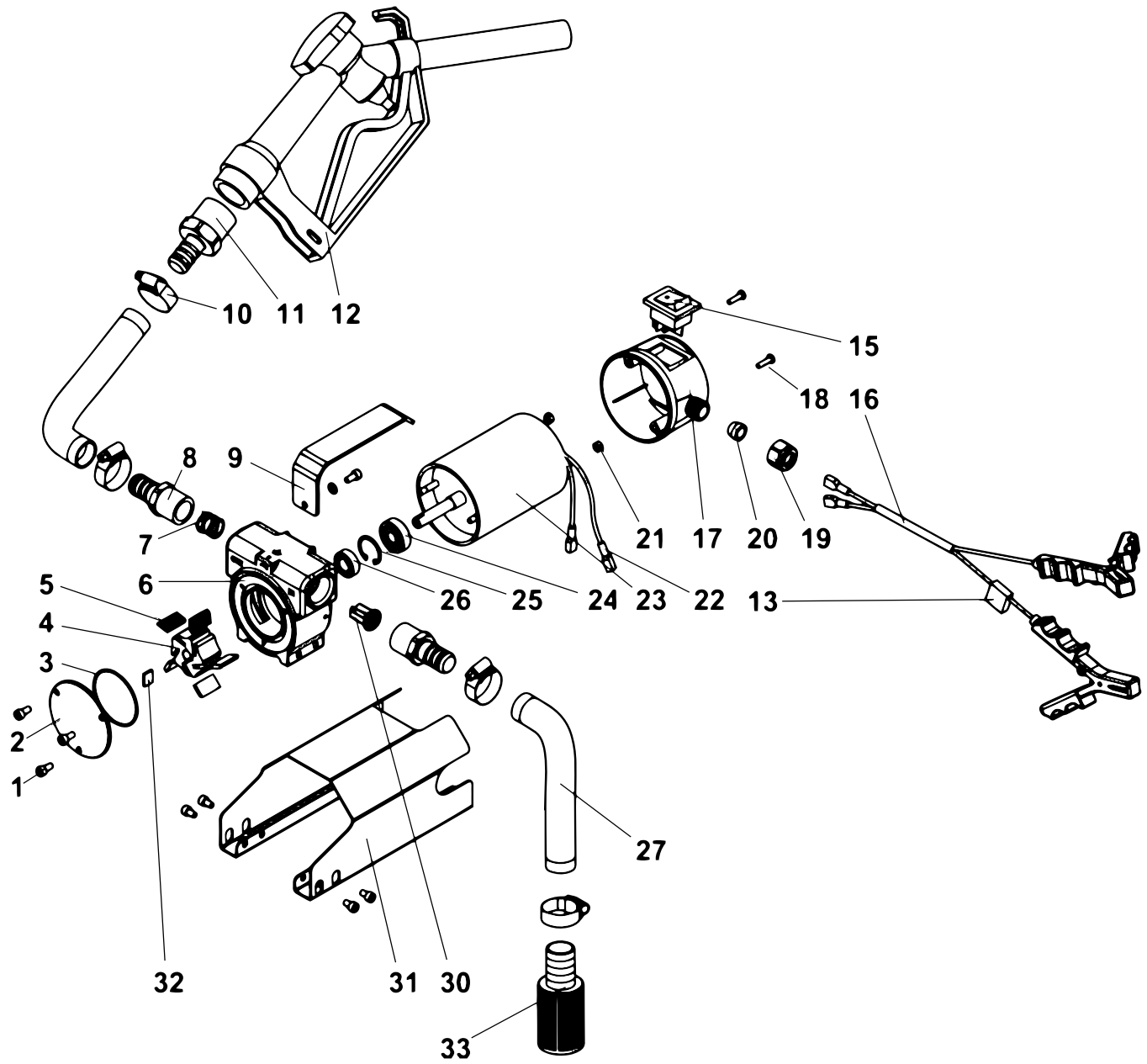

SAFETY

SETUP

OPERATION

MAINTENANCE

Limited 90 Day Warranty

Harbor Freight Tools Co. makes every effort to assure that its products meet high quality and durability standards, and warrants to the original purchaser that this product is free from defects in materials and workmanship for the period of 90 days from the date of purchase. This warranty does not apply to damage due directly or indirectly, to misuse, abuse, negligence or accidents, repairs or alterations outside our facilities, criminal activity, improper installation, normal wear and tear, or to lack of maintenance. We shall in no event be liable for death, injuries to persons or property, or for incidental, contingent, special or consequential damages arising from the use of our product. Some states do not allow the exclusion or limitation of incidental or consequential damages, so the above limitation of exclusion may not apply to you. THIS WARRANTY IS EXPRESSLY IN LIEU OF ALL OTHER WARRANTIES, EXPRESS OR IMPLIED, INCLUDING THE WARRANTIES OF MERCHANTABILITY AND FITNESS.

To take advantage of this warranty, the product or part must be returned to us with transportation charges prepaid. Proof of purchase date and an explanation of the complaint must accompany the merchandise. If our inspection verifies the defect, we will either repair or replace the product at our election or we may elect to refund the purchase price if we cannot readily and quickly provide you with a replacement. We will return repaired products at our expense, but if we determine there is no defect, or that the defect resulted from causes not within the scope of our warranty, then you must bear the cost of returning the product.

This warranty gives you specific legal rights and you may also have other rights which vary from state to state.

PITTSBURGH[™]

26677 Agoura Road • Calabasas, CA 91302 • 1-888-866-5797