

Owner's Manual & Safety Instructions

Save This Manual Keep this manual for the safety warnings and precautions, assembly, operating, inspection, maintenance and cleaning procedures. Write the product's serial number in the back of the manual near the assembly diagram (or month and year of purchase if product has no number). Keep this manual and the receipt in a safe and dry place for future reference.

20g

PITTSBURGH[®] AUTOMOTIVE

67338

1500 LB CAPACITY VEHICLE DOLLIES



Visit our website at: <http://www.harborfreight.com>
Email our technical support at: productsupport@harborfreight.com

When unpacking, make sure that the product is intact and undamaged. If any parts are missing or broken, please call 1-888-866-5797 as soon as possible.

⚠ WARNING

Read this material before using this product. Failure to do so can result in serious injury. **SAVE THIS MANUAL.**

Copyright © 2020 by Harbor Freight Tools®. All rights reserved.
No portion of this manual or any artwork contained herein may be reproduced in any shape or form without the express written consent of Harbor Freight Tools. Diagrams within this manual may not be drawn proportionally. Due to continuing improvements, actual product may differ slightly from the product described herein. Tools required for assembly and service may not be included.

Specifications

Rated Capacity	1500 lb.
----------------	----------

Important Safety Information

1. Study, understand, and follow all instructions before operating this device.
2. Do not exceed rated capacity.
3. Use only on hard level surface.
4. Before moving a load, assure that the load is centered and secured with a load restraint device.
5. No alterations shall be made to this product.
6. Wear ANSI-approved safety goggles and heavy-duty work gloves during use.
7. Keep clear of load's path while placing on and removing from dollies, and while moving.
8. Use as intended only. Do not use for aircraft purposes. Use only in pairs.
9. Inspect before every use; do not use if parts loose or damaged.
10. Be aware of dynamic loading! Sudden load movement may briefly create excess load causing product failure.
11. Use two Vehicle Dollies to support the front or rear end of the vehicle. Use four Dollies (two pairs) to support entire vehicle.
12. Read vehicle owner's manual and instruction manual for Jack (not included) for proper jacking positions before use.
13. Do not work under vehicle while on Dollies.
14. If used for extended storage under vehicle tires, periodically lift vehicle to rotate tires.
15. Keep lifting area free of spectators and do not allow anyone into vehicle while on Dollies.
16. Use wheel chocks when raising front of vehicle for placement onto Dollies.
17. Assemble only according to instructions. Improper assembly can create hazards.
18. This product is not a toy. Do not allow children to play with or near this item.
19. Maintain product labels and nameplates. These carry important safety information. If unreadable or missing, contact Harbor Freight Tools for a replacement.

PITTSBURGH AUTOMOTIVE

Instructions



Read the **ENTIRE IMPORTANT SAFETY INFORMATION** section at the beginning of this document including all text under subheadings therein before set up or use of this product.

Assembly

1. Insert Casters (3) through holes in Frame (4). Fasten using Spring Washers (2) and Acorn Nuts (1).
2. Once Dollies are assembled, roll Dollies along surface to verify all connections are secure and Dollies roll freely.

Operation

1. Chock opposite end wheels to keep vehicle from rolling. Chocks sold separately.
2. Place Dolly in position under raised front or rear wheels and lower vehicle slowly onto Dollies.
3. To move a vehicle supported by four Dollies: remove wheel chocks, unlock Casters, and use Handles to guide vehicle to location.
4. Lock casters once vehicle is in location.

Parts List and Diagram

Part	Description	Qty.
1	Acorn Nut (M12)	8
2	Spring Washer	8
3	Caster	8
4	Frame	2

Note: Some parts are listed and shown for illustration purposes only, and are not available individually as replacement parts. Specify UPC 193175315540 when ordering parts.

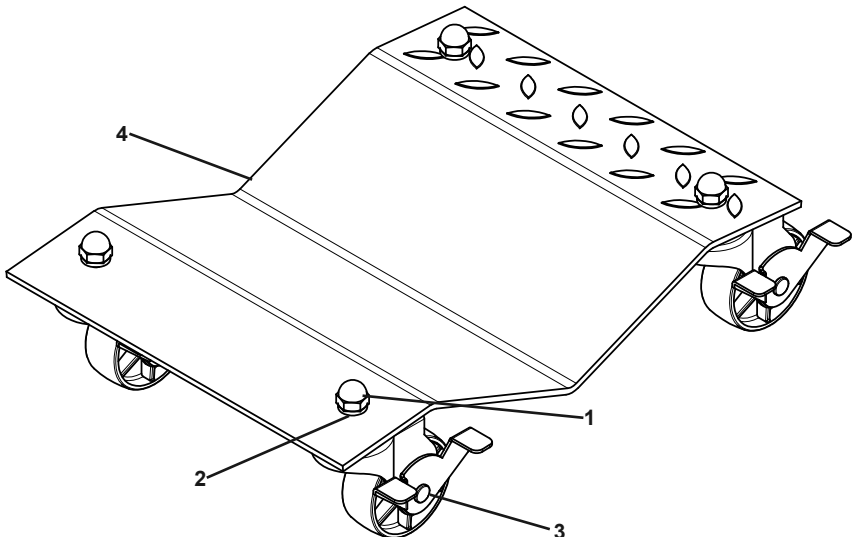

Record Serial Number Here: _____

Note: If product has no serial number, record month and year of purchase instead.

PLEASE READ THE FOLLOWING CAREFULLY

THE MANUFACTURER AND/OR DISTRIBUTOR HAS PROVIDED THE PARTS LIST AND ASSEMBLY DIAGRAM IN THIS DOCUMENT AS A REFERENCE TOOL ONLY. NEITHER THE MANUFACTURER OR DISTRIBUTOR MAKES ANY REPRESENTATION OR WARRANTY OF ANY KIND TO THE BUYER THAT HE OR SHE IS QUALIFIED TO MAKE ANY REPAIRS TO THE PRODUCT, OR THAT HE OR SHE IS QUALIFIED TO REPLACE ANY PARTS OF THE PRODUCT. IN FACT, THE MANUFACTURER AND/OR DISTRIBUTOR EXPRESSLY STATES THAT ALL REPAIRS AND PARTS REPLACEMENTS SHOULD BE UNDERTAKEN BY CERTIFIED AND LICENSED TECHNICIANS, AND NOT BY THE BUYER. THE BUYER ASSUMES ALL RISK AND LIABILITY ARISING OUT OF HIS OR HER REPAIRS TO THE ORIGINAL PRODUCT OR REPLACEMENT PARTS THERETO, OR ARISING OUT OF HIS OR HER INSTALLATION OF REPLACEMENT PARTS THERETO.

Limited 90 Day Warranty

Harbor Freight Tools Co. makes every effort to assure that its products meet high quality and durability standards, and warrants to the original purchaser that this product is free from defects in materials and workmanship for the period of 90 days from the date of purchase. This warranty does not apply to damage due directly or indirectly, to misuse, abuse, negligence or accidents, repairs or alterations outside our facilities, criminal activity, improper installation, normal wear and tear, or to lack of maintenance. We shall in no event be liable for death, injuries to persons or property, or for incidental, contingent, special or consequential damages arising from the use of our product. Some states do not allow the exclusion or limitation of incidental or consequential damages, so the above limitation of exclusion may not apply to you. THIS WARRANTY IS EXPRESSLY IN LIEU OF ALL OTHER WARRANTIES, EXPRESS OR IMPLIED, INCLUDING THE WARRANTIES OF MERCHANTABILITY AND FITNESS.

To take advantage of this warranty, the product or part must be returned to us with transportation charges prepaid. Proof of purchase date and an explanation of the complaint must accompany the merchandise. If our inspection verifies the defect, we will either repair or replace the product at our election or we may elect to refund the purchase price if we cannot readily and quickly provide you with a replacement. We will return repaired products at our expense, but if we determine there is no defect, or that the defect resulted from causes not within the scope of our warranty, then you must bear the cost of returning the product.

This warranty gives you specific legal rights and you may also have other rights which vary from state to state.

PITTSBURGH[®] AUTOMOTIVE

26541 Agoura Road • Calabasas, CA 91302 • 1-888-866-5797