

Owner's Manual & Safety Instructions

Save This Manual Keep this manual for the safety warnings and precautions, assembly, operating, inspection, maintenance and cleaning procedures. Write the product's serial number in the back of the manual near the assembly diagram (or month and year of purchase if product has no number). Keep this manual and the receipt in a safe and dry place for future reference.

20k

PITTSBURGH MOTORCYCLE

1000 LB. CAPACITY MOTORCYCLE LIFT



68892

Visit our website at: <http://www.harborfreight.com>
Email our technical support at: productsupport@harborfreight.com

When unpacking, make sure that the product is intact and undamaged. If any parts are missing or broken, please call 1-888-866-5797 as soon as possible.

Copyright© 2020 by Harbor Freight Tools®. All rights reserved.
No portion of this manual or any artwork contained herein may be reproduced in any shape or form without the express written consent of Harbor Freight Tools. Diagrams within this manual may not be drawn proportionally. Due to continuing improvements, actual product may differ slightly from the product described herein. Tools required for assembly and service may not be included.





⚠ WARNING

Read this material before using this product. Failure to do so can result in serious injury. **SAVE THIS MANUAL.**

Table of Contents

Safety	3	Maintenance	7
Specifications	4	Parts Lists and Assembly Diagrams	8
Assembly	5	Warranty	12
Operation.....	6		

PITTSBURGH *MOTORCYCLE*

WARNING SYMBOLS AND DEFINITIONS	
	This is the safety alert symbol. It is used to alert you to potential personal injury hazards. Obey all safety messages that follow this symbol to avoid possible injury or death.
 DANGER	Indicates a hazardous situation which, if not avoided, will result in death or serious injury.
 WARNING	Indicates a hazardous situation which, if not avoided, could result in death or serious injury.
 CAUTION	Indicates a hazardous situation which, if not avoided, could result in minor or moderate injury.
NOTICE CAUTION	Addresses practices not related to personal injury.

IMPORTANT SAFETY INSTRUCTIONS

WARNING

FAILURE TO HEED THESE INSTRUCTIONS MAY RESULT IN PERSONAL INJURY AND/OR PROPERTY DAMAGE.

1. **Study, understand, and follow all instructions before operating this device.**
2. **Do not exceed 1000 lb. rated capacity.**
3. **Use only on hard, level surfaces.**
4. **Center load on lift platform.**
5. **Immediately after lifting, ensure lift mechanical load holding means is engaged.**
6. **Secure load with appropriate restraint device.**
7. **Do not adjust safety valve.**
8. **Wear ANSI-approved safety goggles and heavy-duty work gloves during use.**
9. **Keep clear of load while lifting and lowering.**
10. **Lower load slowly.**
11. **Do not use for aircraft purposes.**
12. **Apply parking brake and chock tires before lifting vehicle.**
13. **Inspect before every use; do not use if parts are loose or damaged.**
14. **Do not lift motorcycle with rear tire on ramp.**
15. **Keep work area clean and well lit.**
Cluttered or dark areas invite accidents.
16. **Keep children and bystanders away while operating. Distractions can cause you to lose control.**
17. **Stay alert.** Watch what you are doing, and use common sense when operating. Do not use while tired or under the influence of drugs, alcohol, or medication. A moment of inattention while operating may result in serious personal injury.
18. **Store idle lifts out of the reach of children and do not allow persons unfamiliar with the lift or these instructions to operate it.**
Lifts are dangerous in the hands of untrained users.
19. **Have your lift serviced by a qualified repair person using only identical replacement parts.** This will ensure that the safety of the lift is maintained.
20. **Maintain labels and nameplates on the lift.** These carry important information. If unreadable or missing, contact Harbor Freight Tools for a replacement.
21. **Read lifting requirements in service manual of the motorcycle being lifted.**
22. **Industrial applications must follow OSHA requirements.**
23. **Do not allow anyone on the lift or the motorcycle/ATV while on the lift.**
24. **Raise Casters off the ground to prevent movement before loading, unloading, raising, or lowering.**
25. **Before lowering, remove all tools and equipment from under lift.**
26. **Only use this lift to raise a motorcycle or an ATV to perform maintenance.** Do not attempt to transport or relocate motorcycle/ATV while on the Lift.
27. **The warnings, cautions, and instructions discussed in this instruction manual cannot cover all possible conditions and situations that may occur.** It must be understood by the operator that common sense and caution are factors which cannot be built into this product, but must be supplied by the operator.



SAVE THESE INSTRUCTIONS.

Specifications

Max. Load Capacity	1000 lb.
Max. Lift Height	33"
Min. Lift Height	8- ¹ / ₈ "
Ram Travel	4- ¹ / ₄ "
Platform Dimensions	86- ¹ / ₂ " L x 26- ¹ / ₂ " W

PITTSBURGH **MOTORCYCLE**

Assembly Instructions



Read the **ENTIRE IMPORTANT SAFETY INSTRUCTIONS** section at the beginning of this manual including all text under subheadings therein before set up or use of this product.

1. Raise the front of the Frame Asm. (14) and put it on blocks.
2. Assemble the Casters (11) to the Frame Asm. (14) using Bolts (10), Washers (9), and Nuts (8).
3. Thread the Adjustment Screws (13) into the Frame Asm. (14) and attach their bases.
4. Lower the front of the Frame Asm. (14) off the blocks.
5. Attach the Stop Plate (41) to the Platform (36) using Bolts (42), Washers (33), and Nuts (43).
6. Attach the Stop Plate (41) to the Platform (36) using Bolts (42), Washers (33), and Nuts (43).
7. Attach the Foot Pedal (15) to the Pump Input Shaft (18).
8. Attach the Release Pedal (16) to the valve shaft, as shown in Figure C.

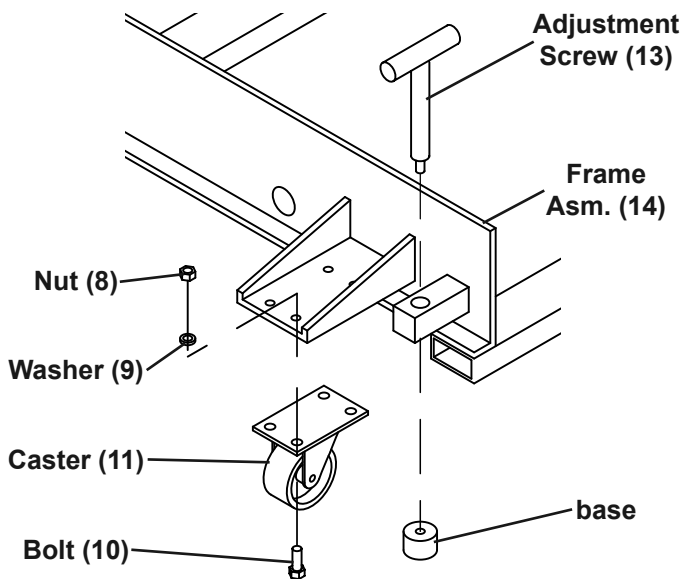

Figure A: Caster and Adjusting Screw Assembly

5. Attach the Vise Base (40) to the front of the Platform (36) using Bolts (42), Washers (33), and Nuts (43).

Note: Location of Vise Base (40) in relation to the Stop Plate (41) is adjustable by means of removing fasteners 42, 33, & 43. Tighten Nuts and Bolts only after determining the proper tire mounting position.

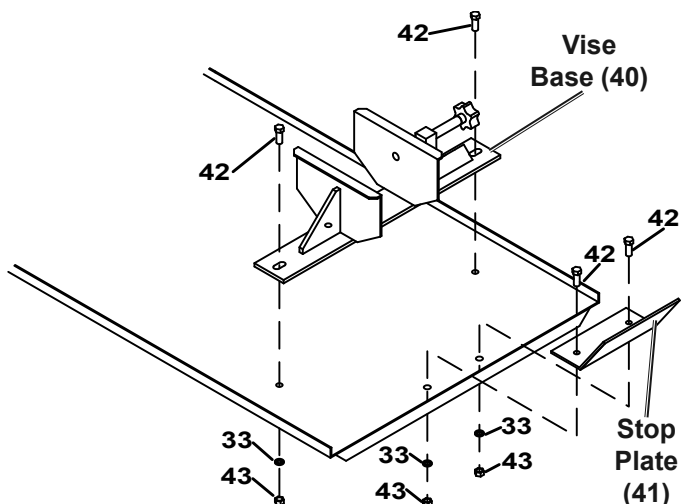

Figure B: Vise Base and Stop Plate Assembly

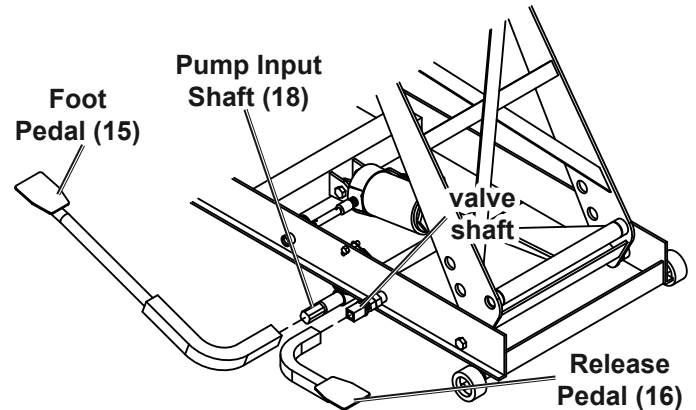

Figure C: Pedal Assembly

9. Use the Access Panel (35) to cover the large hole in the Platform (36).
10. Attach the Ramp (34) to the back of the Platform (36), inserting both pins under the Ramp into the holes in the Platform.

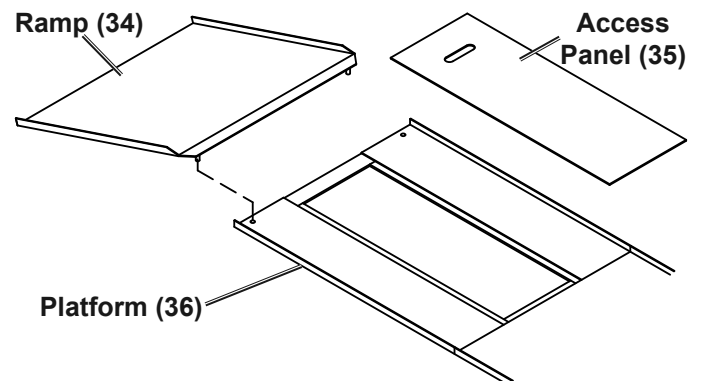

Figure D: Ramp and Access Panel Assembly

Operating Instructions



Read the **ENTIRE IMPORTANT SAFETY INFORMATION** section at the beginning of this manual including all text under subheadings therein before set up or use of this product.

Before First Use

1. Check and fill oil as needed. See **Checking and Filling Hydraulic Fluid** instructions on page 7.
2. Bleed the Lift Jack according to the **Bleeding** instructions on page 7.
3. Test the Lift several times for proper operation before attempting to lift a load. **If, after bleeding twice, the Lift still does not appear to be working properly, do not use the Lift until it has been repaired by a qualified service technician.**

Lifting

1. Position the lift on a flat, level, hard surface able to support at least 1350 lb.
2. Turn the Lifting Screws clockwise to evenly raise the Casters off the ground and limit movement.
3. With the Access Panel in place, roll the motorcycle onto the lift. Kick the center stand of the motorcycle down to stabilize it on the Platform.
4. Clamp the front wheel of the motorcycle into the Vise to prevent movement of the wheel.
5. Once the Stop Plate is adjusted against the motorcycle tire, tighten the Bolts that hold it in place.
6. Secure the motorcycle to the lift using tie-down straps (not included). See motorcycle's owner manual for locations of strap attachments.
7. Pump the Foot Pedal repeatedly to raise the lift.
8. When the platform has been raised to the working height, pass the Locking Bar through the holes in the Rear Lifting Arm so the lift cannot be accidentally lowered.
9. Gently press Release Pedal to lower the platform to rest the load on Locking Bar and not on the lift jack.

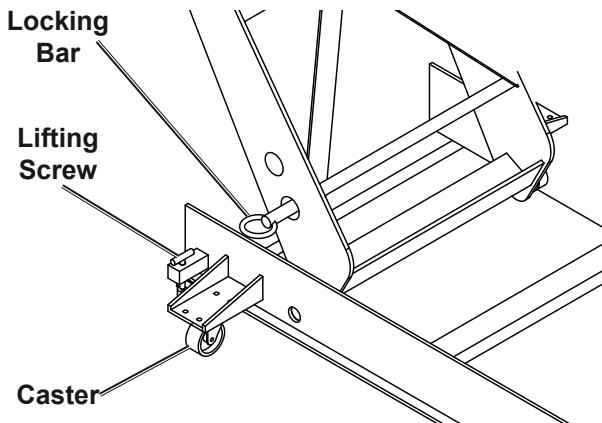

Figure E: Lifting Screw and Locking Bar

Lowering

1. Remove all tools, parts, etc. from under the vehicle.
 2. Slightly raise the platform to free the Locking Bar.
 3. Remove the Locking Bar, then slowly press the Release Pedal to ease down the unit.
 4. After lowering, open the Vise and remove the motorcycle from the lift.
 5. Turn the Lifting Screws counterclockwise to lower the lift onto the Casters.
 6. Store in a safe, dry location out of reach of children.
- NOTE:** The speed of lowering is controlled by the Release Pedal. Operate this Pedal slowly in a controlled and safe manner.

Small ATV Application

1. The Lift can be used to support small ATV's under certain conditions. A small ATV can be rolled onto the Lift if the wheel width of the ATV falls within the 26-3/4" width of the Lift's platform. **Never attempt to ride an ATV onto the platform.** The Lift should not be used to support an ATV unless all 4 tires of the ATV can completely rest on the platform.
2. Use at least 2 wheel chocks (one for a front ATV wheel and one for a back ATV wheel) to prevent movement of the ATV while it is being worked on. Wheel chocks sold separately.
3. Before lifting, secure the ATV to the Lift using tie down straps (not included).

Maintenance and Servicing



Procedures not specifically explained in this manual must be performed only by a qualified technician.

!WARNING

TO PREVENT SERIOUS INJURY FROM TOOL FAILURE:

Do not use damaged equipment. If abnormal noise or vibration occurs, have the problem corrected before further use. Lock the lift with the Locking Bar before servicing in the raised position.

1. **Before each use**, inspect the general condition of the Lift. Check for broken, cracked, or bent parts, loose or missing parts, and any condition that may affect the proper operation of the product. If a problem occurs, have the problem corrected before further use.
Do not use damaged equipment.
2. **If the Lift appears *not* to be working properly, follow *Bleeding* instructions.**
3. The mechanical parts of the Lift, such as the pedal lift and release shafts should be occasionally lubricated with heavy oil or grease.
4. Protect the Lift Cylinder from dirt or grit when in the raised position. If it becomes dirty, wipe it off with a clean cloth before lowering.
5. Maintain and store the Lift in a reasonably protected environment. Do not expose to rain or excess moisture. Protect from salt water or other corrosive materials. If it becomes dirty or contaminated, clean it promptly with clean water or a suitable detergent. If using a pressure washer, be aware that you may remove some paint from the outer surface. Never spray a pressure washer at the seal areas near the pistons or valves. Lubricate external moving parts after cleaning.
6. If the lift slowly lowers on its own, it may have damaged seals or insufficient oil. First check the oil level. If the level is OK, take the lift to a qualified service technician for seal replacement. Damaged seals may be caused by overloading, or exposure to harmful conditions or inappropriate use of a pressure washer.

NOTE: If the lift can be raised to its highest position, it indicates that there is enough oil. If the lift slowly lowers from this position, it indicates that the problem is likely with the seals.

NOTE: Do not tamper with the check valves. Any repairs should be performed by a qualified technician.

Checking and Filling Hydraulic Fluid

1. Lower the lift completely. Remove the Access Panel and the Oil Plug on the side of the Jack underneath.
2. The oil level should be even with the bottom of the filler plug hole. You should be able to see the oil.
3. If the oil level is low, add SAE Hydraulic Jack fluid only. Avoid mixing different brands of oils.
Do not use any other fluid or brake fluid.

Bleeding

Note: If the Lift appears not to be working properly, it may be necessary to *bleed* trapped air from its hydraulic system.

1. Check oil level. Replace plug.
2. Depress Release Pedal.
3. Pump the Foot Pedal several times.
4. Let up on Release Pedal.
5. Pump Foot Pedal.
If the motorcycle lift does not elevate smoothly or Foot Pedal feels “spongy”, repeat steps 2 - 5.

PLEASE READ THE FOLLOWING CAREFULLY

THE MANUFACTURER AND/OR DISTRIBUTOR HAS PROVIDED THE PARTS LIST AND ASSEMBLY DIAGRAM IN THIS MANUAL AS A REFERENCE TOOL ONLY. NEITHER THE MANUFACTURER OR DISTRIBUTOR MAKES ANY REPRESENTATION OR WARRANTY OF ANY KIND TO THE BUYER THAT HE OR SHE IS QUALIFIED TO MAKE ANY REPAIRS TO THE PRODUCT, OR THAT HE OR SHE IS QUALIFIED TO REPLACE ANY PARTS OF THE PRODUCT. IN FACT, THE MANUFACTURER AND/OR DISTRIBUTOR EXPRESSLY STATES THAT ALL REPAIRS AND PARTS REPLACEMENTS SHOULD BE UNDERTAKEN BY CERTIFIED AND LICENSED TECHNICIANS, AND NOT BY THE BUYER. THE BUYER ASSUMES ALL RISK AND LIABILITY ARISING OUT OF HIS OR HER REPAIRS TO THE ORIGINAL PRODUCT OR REPLACEMENT PARTS THERETO, OR ARISING OUT OF HIS OR HER INSTALLATION OF REPLACEMENT PARTS THERETO.

Frame Parts List

Part	Description	Qty
1	Pin	2
2	Washer	22
3	Front Wheel	2
4	Bolt M12x60	8
5	Liner Tube	4
6	Bolt M8x25	2
7	Plate	1
8	Nut M6	8
9	Ø6 Washer	8
10	Bolt M6x16	8
11	Caster	2
12	“U” Bolt	2
13	Adjustment Screw	2
14	Frame Asm.	1
15	Foot Pedal	1
16	Release Pedal	1
17	Nut M16	3
18	Pump Input Shaft	1
19	Bolt M16x85	1
20	Ø16 Washer	1
21	Ø16 Spring Washer	1
22	Bolt M8x30	1
23	Spring	1
24	Release Valve Spindle	1

Part	Description	Qty
25	Pump	1
26	T-connector	1
27	Bolt M10x20	2
28	Pin	1
29	Locking Bar	1
30	Front Lifting Arm	1
31	Rear Lifting Arm	1
32	Handle	1
33	Ø10 Washer	4
34	Ramp	1
35	Access Panel	1
36	Platform	1
37	Nut M12	8
38	Vise Jaw	1
39	Bolt	1
40	Vise Base	1
41	Stop Plate	1
42	Bolt M10x25	4
43	Nut M10	12
44	Nut M8	4
45	Link	2
46	Stud Bolt	1
47	Spring	1



Frame Assembly Diagram

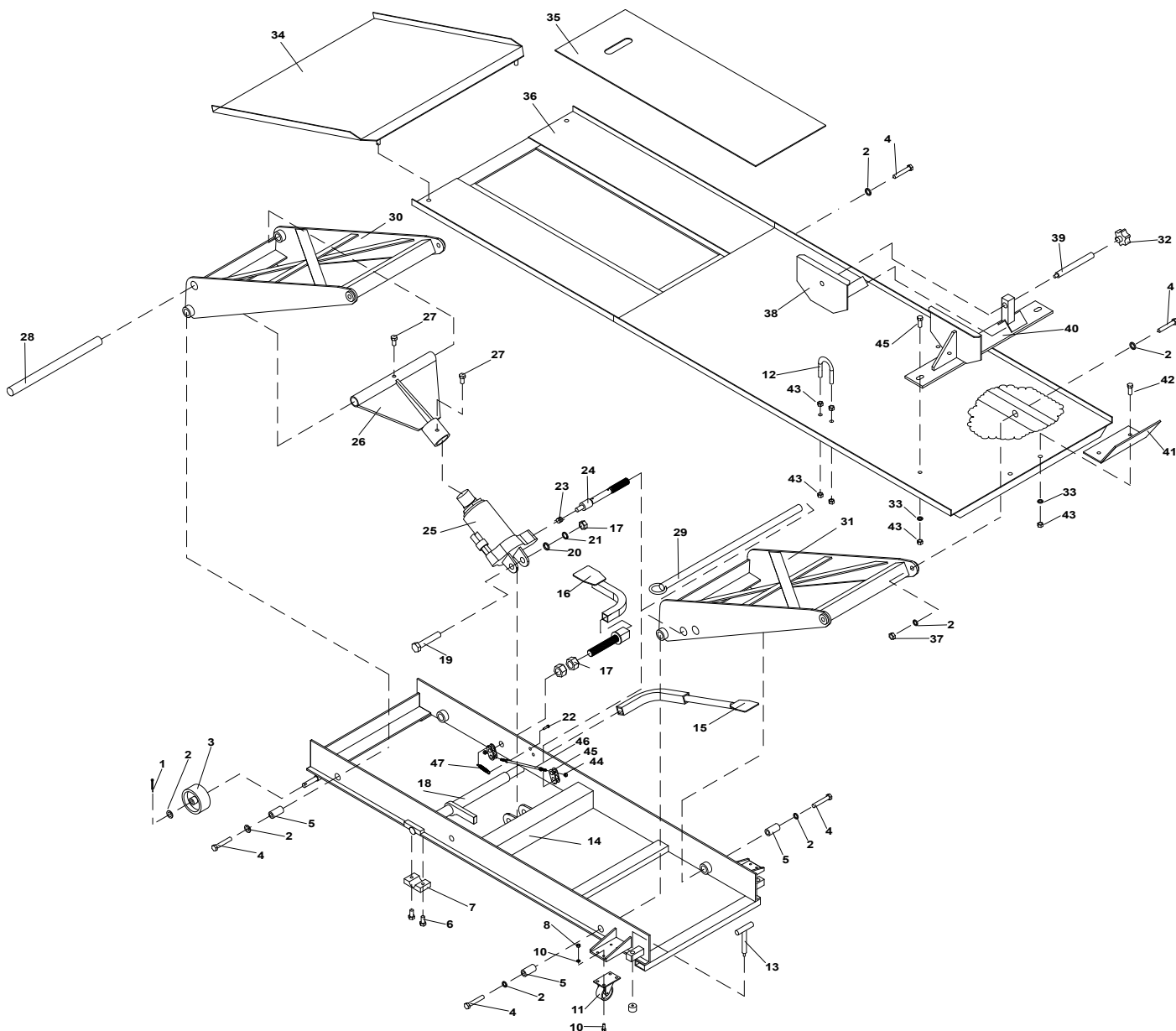

Record Product's Serial Number Here: _____

Note: If product has no serial number, record month and year of purchase instead.

Note: Some parts are listed and shown for illustration purposes only, and are not available individually as replacement parts. Specify UPC 193175054531 when ordering parts.

PITTSBURGH MOTORCYCLE

Parts List A - Pump

Part	Description	Qty
1A	Top Nut	1
2A	O-ring	1
3A	Nylon Ring	1
4A	Reservoir	1
5A	Oil Plug	1
6A	Nylon Ring	1
7A	Piston Rod	1
8A	Nylon Ring	1
9A	O-ring	1
10A	Cylinder	1
11A	Nylon Ring	1
12A	Steel Ball	3
13A	Steel Ball	1
14A	Ring	1
15A	Adjustable Spring	1
16A	Adjustable Screw	1

Part	Description	Qty
17A	O-ring	1
18A	Screw	1
19A	Set Nut	1
20A	R-pin	2
21A	Cover	1
22A	Short Axle	1
23A	Long Axle	1
24A	Pump Piston	1
25A	Sealing Ring	1
26A	O-ring	1
27A	Regulating Plug	1
28A	Copper Washer	1
29A	Release Valve	1
30A	Ring	1
31A	Base	1

PITTSBURGH **MOTORCYCLE**

Assembly Diagram A - Pump

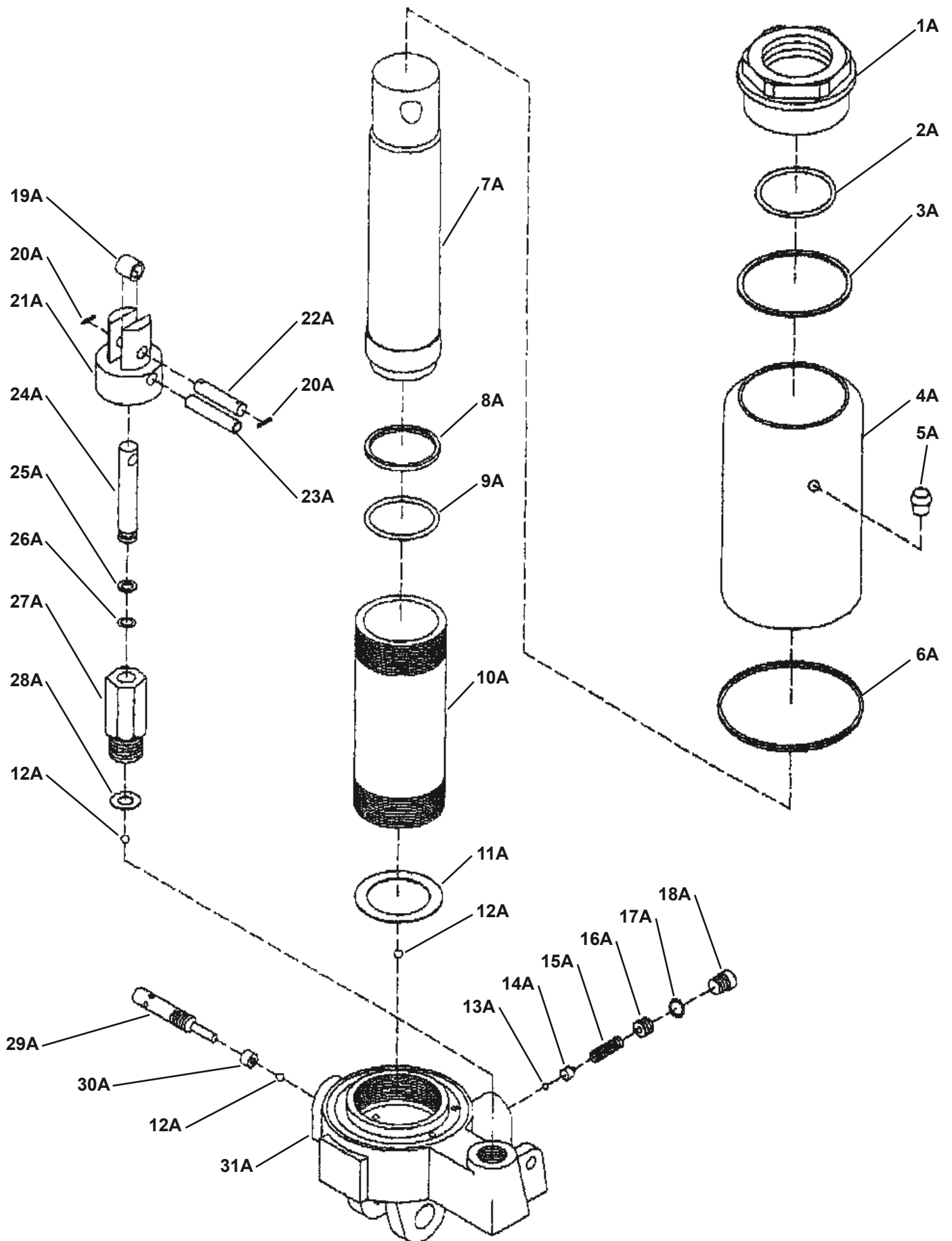

Limited 90 Day Warranty

Harbor Freight Tools Co. makes every effort to assure that its products meet high quality and durability standards, and warrants to the original purchaser that this product is free from defects in materials and workmanship for the period of 90 days from the date of purchase. This warranty does not apply to damage due directly or indirectly, to misuse, abuse, negligence or accidents, repairs or alterations outside our facilities, criminal activity, improper installation, normal wear and tear, or to lack of maintenance. We shall in no event be liable for death, injuries to persons or property, or for incidental, contingent, special or consequential damages arising from the use of our product. Some states do not allow the exclusion or limitation of incidental or consequential damages, so the above limitation of exclusion may not apply to you. THIS WARRANTY IS EXPRESSLY IN LIEU OF ALL OTHER WARRANTIES, EXPRESS OR IMPLIED, INCLUDING THE WARRANTIES OF MERCHANTABILITY AND FITNESS.

To take advantage of this warranty, the product or part must be returned to us with transportation charges prepaid. Proof of purchase date and an explanation of the complaint must accompany the merchandise. If our inspection verifies the defect, we will either repair or replace the product at our election or we may elect to refund the purchase price if we cannot readily and quickly provide you with a replacement. We will return repaired products at our expense, but if we determine there is no defect, or that the defect resulted from causes not within the scope of our warranty, then you must bear the cost of returning the product.

This warranty gives you specific legal rights and you may also have other rights which vary from state to state.

PITTSBURGH **MOTORCYCLE**