

Owner's Manual & Safety Instructions

Save This Manual Keep this manual for the safety warnings and precautions, assembly, operating, inspection, maintenance and cleaning procedures. Write the product's serial number in the back of the manual (or month and year of purchase if product has no number). Keep this manual and the receipt in a safe and dry place for future reference.

22e



METAL SHRINKER/STRETCHER SET



Visit our website at: <http://www.harborfreight.com>
Email our technical support at: productsupport@harborfreight.com

68897

When unpacking, make sure that the product is intact and undamaged. If any parts are missing or broken, please call 1-888-866-5797 as soon as possible.

Copyright© 2022 by Harbor Freight Tools®. All rights reserved.

No portion of this manual or any artwork contained herein may be reproduced in any shape or form without the express written consent of Harbor Freight Tools. Diagrams within this manual may not be drawn proportionally. Due to continuing improvements, actual product may differ slightly from the product described herein.

Tools required for assembly and service may not be included.

⚠ WARNING

**Read this material before using this product.
Failure to do so can result in serious injury.
SAVE THIS MANUAL.**

Table of Contents

Safety	2	Maintenance	6
Specifications	4	Parts List and Diagram	7
Setup	4	Warranty	8
Operation	5		



SAFETY

SETUP

OPERATION

MAINTENANCE

WARNING SYMBOLS AND DEFINITIONS

	This is the safety alert symbol. It is used to alert you to potential personal injury hazards. Obey all safety messages that follow this symbol to avoid possible injury or death.
⚠ DANGER	Indicates a hazardous situation which, if not avoided, will result in death or serious injury.
⚠ WARNING	Indicates a hazardous situation which, if not avoided, could result in death or serious injury.
⚠ CAUTION	Indicates a hazardous situation which, if not avoided, could result in minor or moderate injury.
NOTICE CAUTION	Addresses practices not related to personal injury.

IMPORTANT SAFETY INFORMATION

General Tool Safety Warnings

⚠ WARNING

Read all safety warnings and instructions.

Failure to follow the warnings and instructions may result in electric shock, fire and/or serious injury.

Save all warnings and instructions for future reference.

- Keep work area clean.** Cluttered areas invite injuries.
- Observe work area conditions.** Keep work area well lighted.
- Keep children away.** Do not allow children in the work area. Do not let them handle tools.
- Store idle equipment.** When not in use, store tools in a dry location to inhibit rust. Store out of reach of children.
- Use eye and hand protection.** Wear ANSI-approved impact safety goggles and leather work gloves when setting up and using this product.
- Maintain tools.** Keep tools clean for better and safer performance. Follow instructions for lubricating and changing accessories. The handle must be kept clean, dry and free from oil and grease at all times.

7. **Maintain power tools.** Check for misalignment or binding of moving parts, breakage of parts and any other condition that may affect the power tool's operation. If damaged, have the power tool repaired before use. Many accidents are caused by poorly maintained power tools.
8. **Stay alert.** Watch what you are doing. Do not operate any tool when tired or under the influence of drugs, alcohol or medication.
9. **Replacement parts and accessories.** When servicing, use only identical replacement parts. Use of any other parts will void the warranty. Only use accessories intended for use with this tool.
10. **Use caution when handling workpieces.** Metal workpieces have sharp edges. Use heavy duty gloves when handling the workpiece.
11. **Attach the Metal Shrinker/Stretchers to a stand or table before use.**
12. **Do not use a handle extension to increase force.**
13. **Keep hands and fingers clear of the Jaws when using this tool.**



SAVE THESE INSTRUCTIONS.

Specifications

Operation	Hand operated or Foot pedal (Foot pedal stand sold separately)
Thickness Capacity	16 gauge aluminum 18 gauge mild steel 20 gauge stainless
Bend Capacity	up to 3" radius

Setup - Before Use:



Read the **ENTIRE IMPORTANT SAFETY INFORMATION** section at the beginning of this manual including all text under subheadings therein before set up or use of this product.

WARNING

Note: For additional information regarding the parts listed in the following pages, refer to the Assembly Diagram near the end of this manual.

Assembly/Mounting

1. The Shrinker/Stretchers have pre-drilled holes in their bases able to accept M10 sized bolts (sold separately).
2. Secure each tool to a workbench or stand (sold separately) using appropriate sized bolts, washers and nuts (all sold separately).
3. For portability, the tool may be clamped into the jaws of a vise (sold separately).

Functions

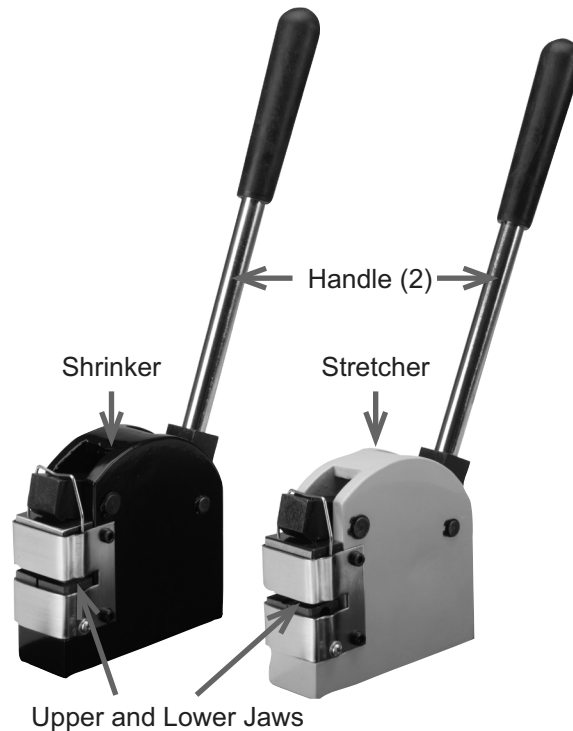

Figure 1

Upper and Lower Jaws

Operating Instructions



Read the **ENTIRE IMPORTANT SAFETY INFORMATION** section at the beginning of this manual including all text under subheadings therein before set up or use of this product.

Work Piece and Work Area Set Up

1. Designate a work area that is clean and well-lit. The work area must not allow access by children or pets to prevent distraction and injury.
2. When forming large pieces, use work horses (sold separately) or other supports to help maneuver the workpiece while forming.

General Operating Instructions

To learn how the metal handles, and how much pressure to use with the tool, practice using the Shrinker/Stretchers on a piece of scrap metal before forming your workpiece. Use a scrap that is the same type of metal and hardness as your workpiece.

Note: If bending a flange as shown below, first form the workpiece's 90° angle using a Sheet Metal Brake (sold separately), creating a maximum flange depth of 1".



Figure 2 - Shrinker



Figure 3 - Stretcher

1. Make a cardboard or wire template of the desired finished size and shape of the workpiece.
2. Working with the leading edge first, insert the workpiece halfway into the jaws.
3. Press firmly on the handle or foot pedal and move the metal back and forth to form the workpiece. The amount of pressure used with the handle determines the amount of bending achieved.
4. Remove the workpiece often and check against the template, continuing until the desired shape is achieved.

Note: Bunching or pocketing that typically occurs when shrinking can be hammered out.

Note: The jaws of the tools are "toothed" to better grip the workpiece. These teeth leave slight markings which can be removed with an abrasive cloth or wheel.

Maintenance and Servicing



Procedures not specifically explained in this manual must be performed only by a qualified technician.

CAUTION

TO PREVENT INJURY FROM TOOL FAILURE:

Do not use damaged equipment. If abnormal noise or vibration occurs, have the problem corrected before further use.

Cleaning, Maintenance, and Lubrication

1. **BEFORE EACH USE**, inspect the general condition of the tool. Check for loose hardware, misalignment or binding of moving parts, cracked or broken parts, and any other condition that may affect its safe operation.
2. When not in use, lightly oil the jaws with machine oil to prevent corrosion.

3. Clean the jaws if tool does not function properly. To clean the jaws:

Note: Refer to the Parts List and Diagram opposite for the following procedure.

- a. Loosen the Screws (25) to remove the Jaw Cover (8), allowing the Jaws to be removed.
- b. Remove the Jaws and V-Block as a single unit, being careful not to lose the Suspension Springs (23).
- c. Remove the Suspension Springs (23) and clean them.

Note: Keep track of the parts' orientation. They need to be replaced in the same way.

- d. There is a small Jaw opposite a large Jaw, top and bottom. Clean the Jaws with cleaning fluid and a bristle brush (sold separately). Do not use a wire brush or a wire wheel. Brush in the same direction as the teeth, with the grooves.
- e. Clean the V-Blocks (10, 13, 17, 20) in the same way.
- f. Lubricate the surface between the Jaws and V-Blocks with machine oil.
- g. Reassembly, being careful to place the large jaws opposite the small Jaws.



PLEASE READ THE FOLLOWING CAREFULLY

THE MANUFACTURER AND/OR DISTRIBUTOR HAS PROVIDED THE PARTS LIST AND ASSEMBLY DIAGRAM IN THIS MANUAL AS A REFERENCE TOOL ONLY. NEITHER THE MANUFACTURER OR DISTRIBUTOR MAKES ANY REPRESENTATION OR WARRANTY OF ANY KIND TO THE BUYER THAT HE OR SHE IS QUALIFIED TO MAKE ANY REPAIRS TO THE PRODUCT, OR THAT HE OR SHE IS QUALIFIED TO REPLACE ANY PARTS OF THE PRODUCT. IN FACT, THE MANUFACTURER AND/OR DISTRIBUTOR EXPRESSLY STATES THAT ALL REPAIRS AND PARTS REPLACEMENTS SHOULD BE UNDERTAKEN BY CERTIFIED AND LICENSED TECHNICIANS, AND NOT BY THE BUYER. THE BUYER ASSUMES ALL RISK AND LIABILITY ARISING OUT OF HIS OR HER REPAIRS TO THE ORIGINAL PRODUCT OR REPLACEMENT PARTS THERETO, OR ARISING OUT OF HIS OR HER INSTALLATION OF REPLACEMENT PARTS THERETO.

Parts List

Part	Description	Qty
1	Base	2
2	Handle	2
3	Handle Cover	2
4	Back Block	2
5	Back Shaft	2
6	Front Block	2
7	Front Shaft	2
8	Jaw Cover	1
9	Shrinker Hook	1
10	Shrinker Upper V-Block	1
11	Shrinker Upper Small Jaw	1
12	Shrinker Lower Small Jaw	1
13	Shrinker Lower V-Block	1
14	Shrinker Upper Large Jaw	1
15	Shrinker Lower Large Jaw	1
16	Stretcher Hook	1
17	Stretcher Upper V-Block	1
18	Stretcher Upper Jaw 1	1
19	Stretcher Lower Jaw 1	1

Part	Description	Qty
20	Stretcher Lower V-Block	1
21	Stretcher Upper Jaw 2	1
22	Stretcher Lower Jaw 2	1
23	Suspension Spring	4
24	Spring	2
25	Screw M5X8	8
26	Pin	4
27	Washer 10mm	4
28	Washer 13mm	4
29	C-Ring	4
30	C-Ring	4
31	Screw M5X12	4
32	Washer 5mm	4
33	Screw M5X25	2
34	Screw M8X20	2
35	Screw M6X10	2
36	Hex Head Wrench 3mm	1
37	Hex Head Wrench 4mm	1
38	Jaw Cover	1

Assembly Diagram

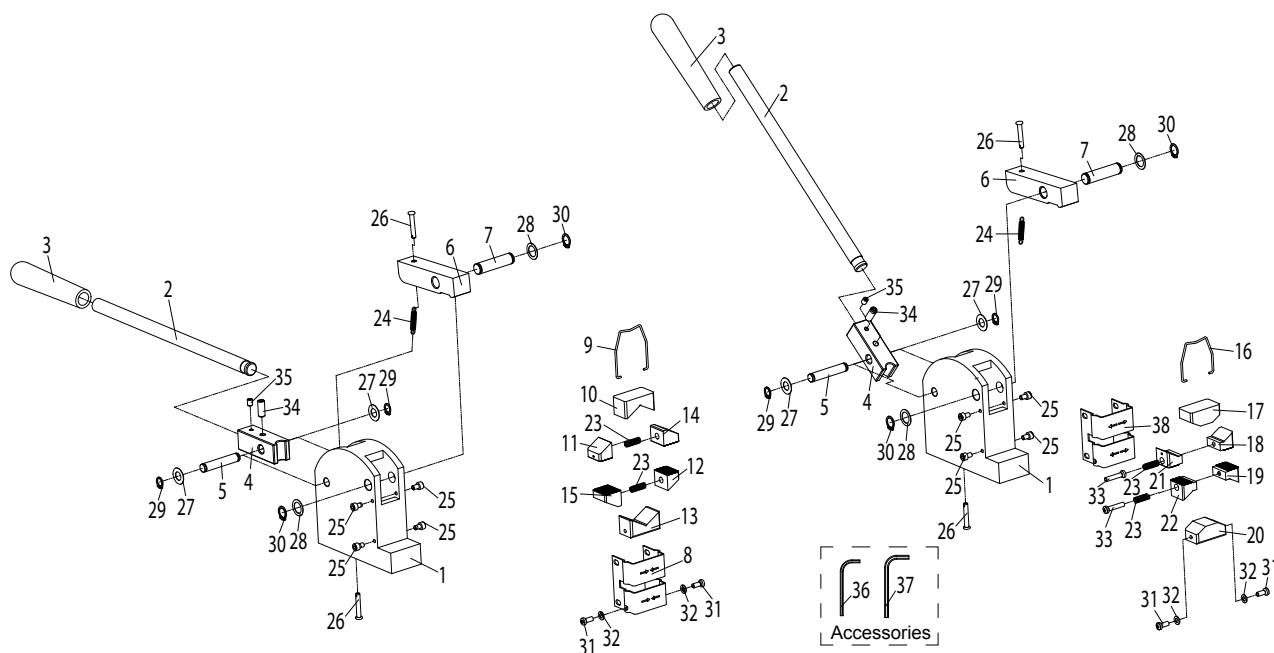

SAFETY

SETUP

OPERATION

MAINTENANCE

Record Product's Serial Number Here: _____

Note: If product has no serial number, record month and year of purchase instead.

Note: Some parts are listed and shown for illustration purposes only, and are not available individually as replacement parts. Specify UPC 792363688970 when ordering parts.

Limited 90 Day Warranty

Harbor Freight Tools Co. makes every effort to assure that its products meet high quality and durability standards, and warrants to the original purchaser that this product is free from defects in materials and workmanship for the period of 90 days from the date of purchase. This warranty does not apply to damage due directly or indirectly, to misuse, abuse, negligence or accidents, repairs or alterations outside our facilities, criminal activity, improper installation, normal wear and tear, or to lack of maintenance. We shall in no event be liable for death, injuries to persons or property, or for incidental, contingent, special or consequential damages arising from the use of our product. Some states do not allow the exclusion or limitation of incidental or consequential damages, so the above limitation of exclusion may not apply to you. THIS WARRANTY IS EXPRESSLY IN LIEU OF ALL OTHER WARRANTIES, EXPRESS OR IMPLIED, INCLUDING THE WARRANTIES OF MERCHANTABILITY AND FITNESS.

To take advantage of this warranty, the product or part must be returned to us with transportation charges prepaid. Proof of purchase date and an explanation of the complaint must accompany the merchandise. If our inspection verifies the defect, we will either repair or replace the product at our election or we may elect to refund the purchase price if we cannot readily and quickly provide you with a replacement. We will return repaired products at our expense, but if we determine there is no defect, or that the defect resulted from causes not within the scope of our warranty, then you must bear the cost of returning the product.

This warranty gives you specific legal rights and you may also have other rights which vary from state to state.

