

Owner's Manual & Safety Instructions

Save This Manual Keep this manual for the safety warnings and precautions, assembly, operating, inspection, maintenance and cleaning procedures. Write the product's serial number in the back of the manual near the assembly diagram (or month and year of purchase if product has no number). Keep this manual and the receipt in a safe and dry place for future reference.

CHICAGO ELECTRIC  **WELDING**

100 LB. CAPACITY WELDING CART



Visit our website at: <http://www.harborfreight.com>
Email our technical support at: tech@harborfreight.com

ITEM 69340

When unpacking, make sure that the product is intact and undamaged. If any parts are missing or broken, please call 1-800-444-3353 as soon as possible.

WARNING

**Read this material before using this product.
Failure to do so can result in serious injury.
SAVE THIS MANUAL.**

Copyright© 2012 by Harbor Freight Tools®. All rights reserved.
No portion of this manual or any artwork contained herein may be reproduced in any shape or form without the express written consent of Harbor Freight Tools. Diagrams within this manual may not be drawn proportionally. Due to continuing improvements, actual product may differ slightly from the product described herein. Tools required for assembly and service may not be included.

Specifications

Weight Capacity	100 lb.
Overall Dim.	27-3/4" x 16-1/2" x 30-1/2"
Cylinder Chain Dim.	32-1/4" L x 5/8" D
Torch Assy. Bracket	6" H x 1-7/8" W x 3/4" D
Tank Capacity	11-1/4" x 10-1/8"



Important Safety Information

Assembly Precautions

1. Assemble only according to these instructions. Improper assembly can create hazards.
2. Wear ANSI-approved safety goggles and heavy-duty work gloves during assembly.
3. Keep assembly area clean and well lit.
4. Keep bystanders out of the area during assembly.
5. Do not assemble when tired or when under the influence of drugs or medication.
6. Weight capacity and other product capabilities apply to properly and completely assembled product only.

Use Precautions

1. This product is not a toy. Do not allow children to play with or near this item.
2. Use as intended only.
3. Inspect before every use; do not use if parts are loose or damaged.
4. Do not exceed listed weight capacity, evenly distributed and balanced.
Be aware of dynamic loading!
Sudden load movement may briefly create excess load causing product failure.
5. Maintain product labels and nameplates. These carry important safety information. If unreadable or missing, contact Harbor Freight Tools for a replacement.
6. Operate and store the Cart on a flat, dry, level surface.
7. Read welding equipment manual before use.
8. If using gas cylinders, be especially careful to prevent tipping or damage to the cylinders. Follow gas cylinder supplier's and gas supplier's safety instructions at all times.

Assembly Instructions



Read the **ENTIRE IMPORTANT SAFETY INFORMATION** section at the beginning of this document including all text under subheadings therein before set up or use of this product.

Note: When attaching hardware, hand tighten only until the unit is together, then use the appropriate tools to tighten the hardware.

1. Put a Wheel (12) on the end of the Axle (13) and secure it with Washer (11) and Cotter Pin (10). See Figure A. Repeat on the other side.
2. Using four Bolts (9) and Nuts (7), attach a Caster (6) to the Bottom Shelf (5). See Figure B. Repeat on other side.

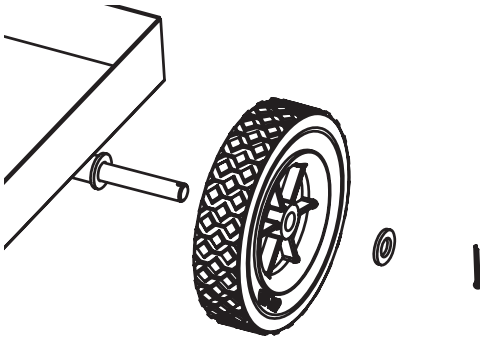

Figure A: Wheel Attachment

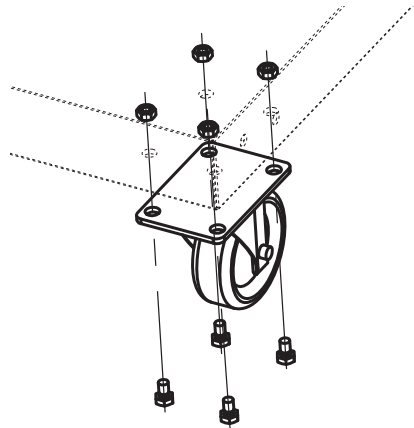

Figure B: Caster (6) Attachment

CHICAGO  **ELECTRIC** **WELDING**

3. Connect the bottom (note the hole locations in the diagram) of the Left Support (4) to the Bottom Shelf (5) using Bolts (9) and Nuts (7). See Figure C. Repeat on other side with Right Support (8).

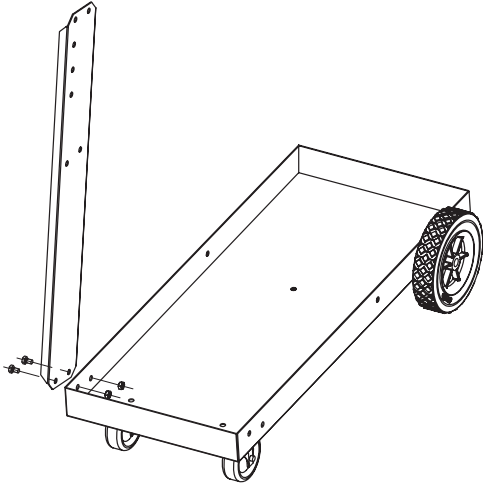

Figure C: Connection of Bottom Shelf (5) and Left Support (4)

4. Attach the Middle Shelf (3) to the Left and Right Supports (4,8) using Bolts (9) and Nuts (7).
5. Place a Hook (2) over the holes on the outside of the top of a Support (4/8), and place the Bolts (9) through both the Hook (2), Support (4), and the Top Shelf (1). Secure with Nuts (7). Repeat on other side.
6. Attach the Back Panel (14) to the Bottom Shelf (5) using Bolts (9) and Nuts (7).
7. Attach the Back Panel (14) to the Middle Shelf (3) and the Top Shelf (1) using Bolts (9) and Nuts (7).
8. Insert the Chains (15) through the holes in the Back Panel (14).
9. Wrench tighten all of the hardware.



Operation

1. Make sure that the welder and all accessories combined do not exceed the weight capacity of this cart.
2. Place any gas cylinders on the back shelf, and secure in place with both chains. Adjust chains' length to hold the cylinder(s) securely.
3. Place the welder on the top shelf and the other accessories on the other shelves.
4. Make sure everything is secure and the cart is well balanced. If the welder is unstable or does not fit securely on the shelf, do not use that welder with this cart.

Maintenance

1. Periodically tighten all of the hardware.
2. Make sure the casters and wheels are free of all dirt, debris, or grease.



Parts List and Diagram

Part	Description	Qty.
1	Top Shelf	1
2	Hook	2
3	Middle Shelf	1
4	Left Support	1
5	Bottom Shelf	1
6	Caster (Ø2.5")	2
7	Nut (M6)	34
8	Right Support	1

Part	Description	Qty.
9	Bolt (M6 x 10)	34
10	Cotter Pin (2.5 x 25)	2
11	Washer (Ø12mm)	4
12	Wheel (Ø6")	2
13	Axle	1
14	Back Panel	1
15	Chain	2

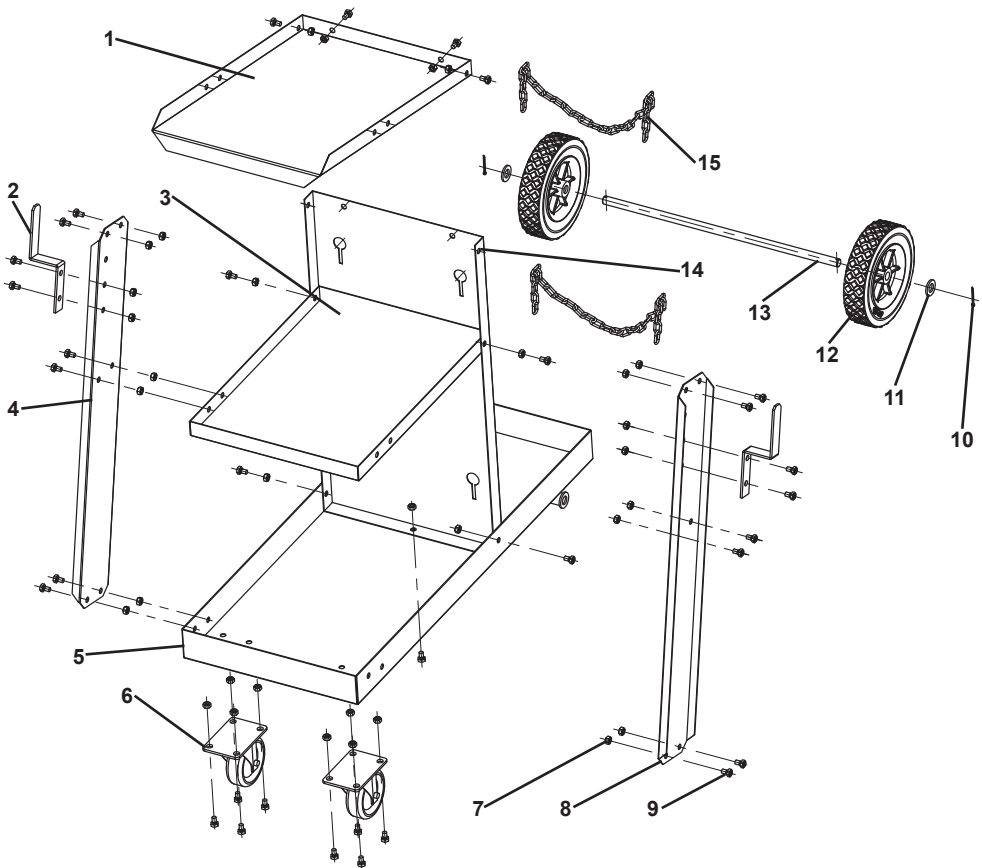

Record Serial Number Here: _____

Note: If product has no serial number, record month and year of purchase instead.

Note: Some parts are listed and shown for illustration purposes only, and are not available individually as replacement parts.

PLEASE READ THE FOLLOWING CAREFULLY

THE MANUFACTURER AND/OR DISTRIBUTOR HAS PROVIDED THE PARTS LIST AND ASSEMBLY DIAGRAM IN THIS DOCUMENT AS A REFERENCE TOOL ONLY. NEITHER THE MANUFACTURER OR DISTRIBUTOR MAKES ANY REPRESENTATION OR WARRANTY OF ANY KIND TO THE BUYER THAT HE OR SHE IS QUALIFIED TO MAKE ANY REPAIRS TO THE PRODUCT, OR THAT HE OR SHE IS QUALIFIED TO REPLACE ANY PARTS OF THE PRODUCT. IN FACT, THE MANUFACTURER AND/OR DISTRIBUTOR EXPRESSLY STATES THAT ALL REPAIRS AND PARTS REPLACEMENTS SHOULD BE UNDERTAKEN BY CERTIFIED AND LICENSED TECHNICIANS, AND NOT BY THE BUYER. THE BUYER ASSUMES ALL RISK AND LIABILITY ARISING OUT OF HIS OR HER REPAIRS TO THE ORIGINAL PRODUCT OR REPLACEMENT PARTS THERETO, OR ARISING OUT OF HIS OR HER INSTALLATION OF REPLACEMENT PARTS THERETO.

Limited 90 Day Warranty

Harbor Freight Tools Co. makes every effort to assure that its products meet high quality and durability standards, and warrants to the original purchaser that this product is free from defects in materials and workmanship for the period of 90 days from the date of purchase. This warranty does not apply to damage due directly or indirectly, to misuse, abuse, negligence or accidents, repairs or alterations outside our facilities, criminal activity, improper installation, normal wear and tear, or to lack of maintenance. We shall in no event be liable for death, injuries to persons or property, or for incidental, contingent, special or consequential damages arising from the use of our product. Some states do not allow the exclusion or limitation of incidental or consequential damages, so the above limitation of exclusion may not apply to you. THIS WARRANTY IS EXPRESSLY IN LIEU OF ALL OTHER WARRANTIES, EXPRESS OR IMPLIED, INCLUDING THE WARRANTIES OF MERCHANTABILITY AND FITNESS.

To take advantage of this warranty, the product or part must be returned to us with transportation charges prepaid. Proof of purchase date and an explanation of the complaint must accompany the merchandise. If our inspection verifies the defect, we will either repair or replace the product at our election or we may elect to refund the purchase price if we cannot readily and quickly provide you with a replacement. We will return repaired products at our expense, but if we determine there is no defect, or that the defect resulted from causes not within the scope of our warranty, then you must bear the cost of returning the product.

This warranty gives you specific legal rights and you may also have other rights which vary from state to state.

