

# Owner's Manual & Safety Instructions

**Save This Manual** Keep this manual for the safety warnings and precautions, assembly, operating, inspection, maintenance and cleaning procedures. Write the product's serial number in the back of the manual near the assembly diagram (or month and year of purchase if product has no number). Keep this manual and the receipt in a safe and dry place for future reference.

19j



## Weatherproof Color Security Camera



Visit our website at: <http://www.harborfreight.com>  
Email our technical support at: [productsupport@harborfreight.com](mailto:productsupport@harborfreight.com)

**69654**





When unpacking, make sure that the product is intact and undamaged. If any parts are missing or broken, please call 1-888-866-5797 as soon as possible.

### **⚠ WARNING**

Read this material before using this product. Failure to do so can result in serious injury. **SAVE THIS MANUAL.**

Copyright© 2012 by Harbor Freight Tools®. All rights reserved.  
No portion of this manual or any artwork contained herein may be reproduced in any shape or form without the express written consent of Harbor Freight Tools. Diagrams within this manual may not be drawn proportionally. Due to continuing improvements, actual product may differ slightly from the product described herein. Tools required for assembly and service may not be included.

## WARNING SYMBOLS AND DEFINITIONS

	This is the safety alert symbol. It is used to alert you to potential personal injury hazards. Obey all safety messages that follow this symbol to avoid possible injury or death.
 <b>DANGER</b>	Indicates a hazardous situation which, if not avoided, will result in death or serious injury.
 <b>WARNING</b>	Indicates a hazardous situation which, if not avoided, could result in death or serious injury.
 <b>CAUTION</b>	Indicates a hazardous situation which, if not avoided, could result in minor or moderate injury.
<b>NOTICE</b> <b>CAUTION</b>	Addresses practices not related to personal injury.

## Important Safety Information

### **WARNING**

**Read all safety warnings and instructions.**

*Failure to follow the warnings and instructions may result in electric shock, fire and/or serious injury.*

**Save all warnings and instructions for future reference.**

## Installation Safety

---

1. **Keep children and bystanders away while installing a camera.** *Distractions can cause you to lose control.*
2. **Do not overreach when installing this product. Keep proper footing and balance at all times.** *This enables better control in unexpected situations.*
3. Wear ANSI-approved safety goggles during installation.
4. This product is not a toy. Mount it out of reach of children.

## Operation Safety

---

1. **Do not operate electrically powered products in explosive atmospheres, such as in the presence of flammable liquids, gases, or dust.** *Electrically powered products create sparks which may ignite the dust or fumes.*
2. **The adapter must match the outlet. Never modify the plug in any way.** *Unmodified plugs and matching outlets will reduce risk of electric shock.*
3. **Do not expose the Power Adapter of this product to rain or wet conditions.** *Water entering the Power Adapter will increase the risk of electric shock.*
4. **Do not abuse the Power Cord. Never use the cord for unplugging the plug from the outlet. Keep cord away from heat, oil, sharp edges or moving parts.** *Damaged or entangled cords increase the risk of electric shock.*
5. The warnings, precautions, and instructions discussed in this instruction manual cannot cover all possible conditions and situations that may occur. It must be understood by the operator that common sense and caution are factors which cannot be built into this product, but must be supplied by the operator.

## Service Safety

---

1. **Product service must be performed only by a qualified technician.**
2. **When servicing a product, use only identical replacement parts.**
3. **Maintain this product with care. Keep this product clean.** *Do not use a damaged product. Tag damaged products "Do not use" until repaired.*
4. **Disconnect the Power Adapter from the power source before making any adjustments, changing accessories, or storing this product.** *Such preventive safety measures reduce the risk of electric shock.*
5. Maintain labels and nameplates on the camera. These carry important safety information. If unreadable or missing, contact Harbor Freight Tools for a replacement.



**SAVE THESE INSTRUCTIONS.**

# Grounding

## ⚠ WARNING



**TO PREVENT ELECTRIC SHOCK AND DEATH FROM INCORRECT GROUNDING WIRE CONNECTION:**

Check with a qualified electrician if you are in doubt as to whether the outlet is properly grounded. Do not modify the power cord plug provided with the camera. Never remove the grounding prong from the plug. Do not use the camera if the power cord or plug is damaged. If damaged, have it repaired by a service facility before use. If the plug will not fit the outlet, have a proper outlet installed by a qualified electrician.

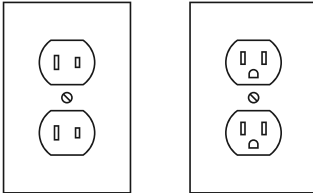

Figure A: Outlets for 2-Prong Plug

1. The included adapter does not require grounding.
2. The adapter may be used in either of the 120 volt outlets shown in the preceding illustration. (See Figure A.)

## Extension Cords

**Note:** Do not use an extension cord with this item's adapter.

## Symbology

	Double Insulated
<b>VAC</b>	Volts Alternating Current

<b>A</b>	Amperes
----------	---------

## Specifications

Power Adapter	120 VAC / 60 Hz Input 12 VDC / 200 mA Output
Resolution	300 x 380 TV lines
Cable	80 feet
Angle	40° down, 20° up, 360° side to side

Night Vision Type	Infrared LED's with Low Light Sensor
Image Type	Daylight: Color Infrared: Black & White
Operating Temperature	14° to 122° F

# Installation Instructions



Read the **ENTIRE IMPORTANT SAFETY INFORMATION** section at the beginning of this manual including all text under subheadings therein before set up or use of this product.

## **WARNING**

**TO PREVENT SERIOUS INJURY FROM ELECTRIC SHOCK:**

**Unplug the Power Adapter from its electrical outlet before installation.**

## Components

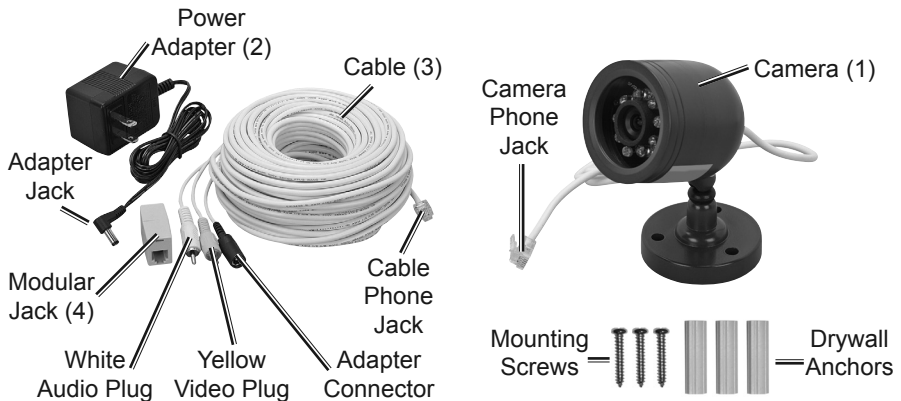

**Figure B**

## Before Mounting

1. Before mounting the Security Camera, test the camera by connecting all the cables and making sure that the unit functions properly as described in the following Set Up section.
2. When planning the mounting location and angle of the Camera, consider the following:
  - a. Do not mount the Camera in bright or direct sunlight.
  - b. At night windows can reflect back into the Camera, interfering with the image. Test the Camera in the intended location before mounting.
  - c. Choose a location high enough so that it is out of reach of children and others who might tamper with the unit, but still covers the desired viewing area adequately.
  - d. Take into consideration the length of the cable and the need to place the Modular Jack (4) in a safe, dry location. Do not expose the modular Jack to weather. Route the cord so as to avoid a tripping hazard.

# Mounting

---

The Security Camera can be mounted with the Camera Base, so that its position is adjustable, or the base can be removed and the Camera can be mounted in a stationary position. If the camera is to be mounted outdoors, do not use the adhesive pad for attachment.

## Mounting the Camera with the Base

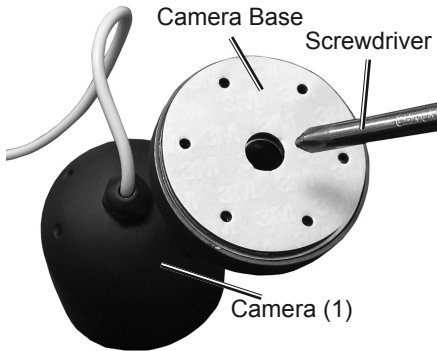

**Figure C**

1. Adjust the Camera to the desired angle:
  - a. Insert a Phillips head screwdriver (sold separately) into the center of the Camera base and loosen the bolt.
  - b. Adjust the angle of the Camera, then tighten the bolt.

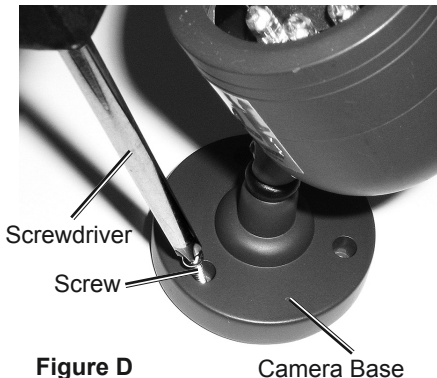

**Figure D**

2. Mount the Camera to the chosen location, using the three included bolts through the three holes in the Camera Base.

**WARNING!** Check for hidden wiring before securing.

**Note:** The adhesive pad can be used instead of the screws for indoor locations.

**Do not use adhesive pad to mount outdoors, it is not weatherproof.**

## Mounting the Camera without the Base

1. Using a Phillips head screwdriver (sold separately), unthread the two screws that hold the Camera Base in place and remove the Camera Base. Store in a dry safe place.
2. Use the holes on the back of the Camera to secure the unit in place. Note the angle of the holes when planning any drilling.

## Cable Connection

---

1. Use the Modular Jack (4) to connect the Camera Phone Jack to the Cable Phone Jack.
2. Insert the Yellow Plug of the Cable (3) into the television's Video Input Port (television/monitor sold separately).
3. Insert the White Plug of the Cable (3) into the television's Audio Input Port.
4. Insert the Power Adapter's (2) plug into the black Power Connector of the Cable (3).
5. Then, plug the Power Adapter (2) into the nearest 120 volt, grounded, electrical outlet.

**CAUTION!** The Power Adapter **MUST** be used indoors in a clean, dry location.

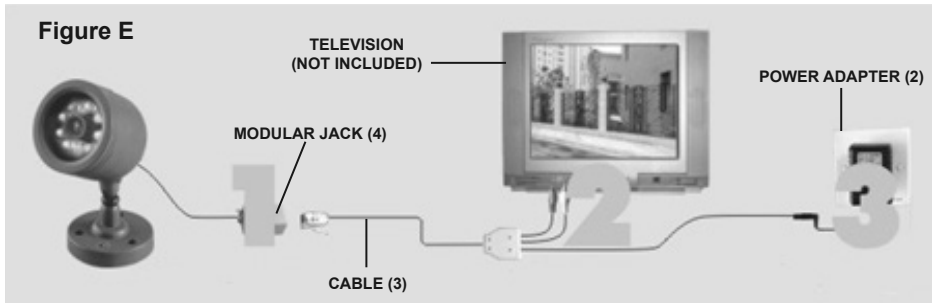

 **Bunker Hill Security**®

## Operating Instructions



Read the **ENTIRE IMPORTANT SAFETY INFORMATION** section at the beginning of this manual including all text under subheadings therein before set up or use of this product.

1. Turn on the television and set to video/AV mode. The camera's view should appear on the screen.
2. The Camera will operate continuously (day and night) while the Power Adapter (2) is plugged in.
3. When not using the Camera, unplug the Power Adapter (2) from the electrical outlet.





# Inspection, Maintenance, and Cleaning



Procedures not specifically explained in this manual must be performed only by a qualified technician.



**TO PREVENT SERIOUS INJURY FROM ELECTRIC SHOCK:**  
Unplug the Power Adapter from its electrical outlet

before inspection, maintenance, or cleaning.

- BEFORE EACH USE**, inspect the general condition of the Camera. Check for loose screws, misalignment or binding of moving parts, cracked or broken parts, damaged electrical wiring, and any other condition that may affect its safe operation. If a problem occurs, have the problem corrected before further use.  
**Do not use damaged equipment.**
- WEEKLY:** Wipe off Camera Lens with a soft, clean, moist cloth. Then dry.

## Troubleshooting

Problem	Possible Causes	Probable Solutions
Camera does not work.	1. No power at outlet. 2. Cables not properly connected.	1. Check power at outlet. 2. Check that all cables are securely connected.
Poor image quality.	Camera lens is dirty.	Clean Camera lens.
View undesirable.	Camera out of adjustment.	Adjust Camera up, down, left, and right to obtain desired view.
Image on the television is upside down.	Camera not mounted correctly.	Reposition camera mount to mounting holes at the top rear of the camera (see page 8).

## Parts List and Diagram

Part	Description	Qty
1	Camera	1
2	Power Adapter	1
3	Cable	1
4	Modular Jack	1

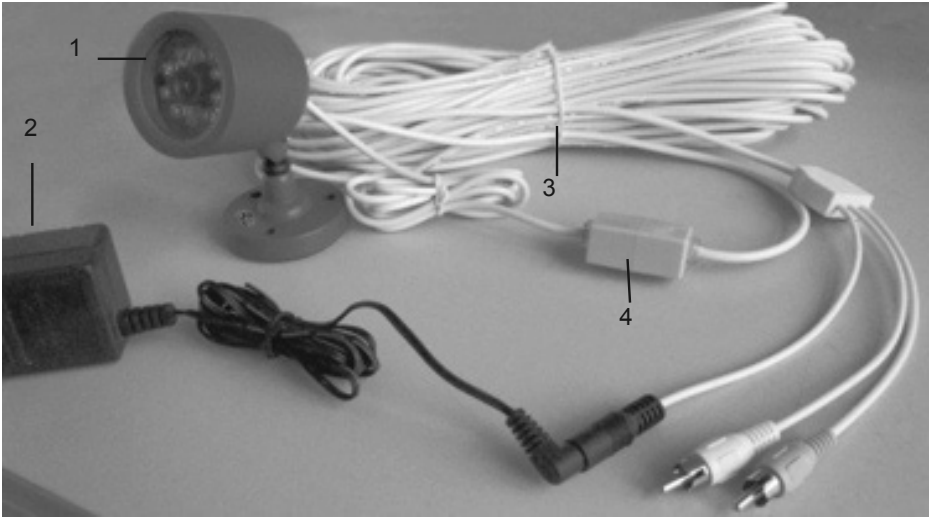

**Record Product's Serial Number Here:** \_\_\_\_\_

**Note:** If product has no serial number, record month and year of purchase instead.

**Note:** Some parts are listed and shown for illustration purposes only, and are not available individually as replacement parts. Specify UPC 792363696548 when ordering parts.

## **PLEASE READ THE FOLLOWING CAREFULLY**

---

THE MANUFACTURER AND/OR DISTRIBUTOR HAS PROVIDED THE PARTS LIST AND ASSEMBLY DIAGRAM IN THIS MANUAL AS A REFERENCE TOOL ONLY. NEITHER THE MANUFACTURER OR DISTRIBUTOR MAKES ANY REPRESENTATION OR WARRANTY OF ANY KIND TO THE BUYER THAT HE OR SHE IS QUALIFIED TO MAKE ANY REPAIRS TO THE PRODUCT, OR THAT HE OR SHE IS QUALIFIED TO REPLACE ANY PARTS OF THE PRODUCT. IN FACT, THE MANUFACTURER AND/OR DISTRIBUTOR EXPRESSLY STATES THAT ALL REPAIRS AND PARTS REPLACEMENTS SHOULD BE UNDERTAKEN BY CERTIFIED AND LICENSED TECHNICIANS, AND NOT BY THE BUYER. THE BUYER ASSUMES ALL RISK AND LIABILITY ARISING OUT OF HIS OR HER REPAIRS TO THE ORIGINAL PRODUCT OR REPLACEMENT PARTS THERETO, OR ARISING OUT OF HIS OR HER INSTALLATION OF REPLACEMENT PARTS THERETO.

## Limited 90 Day Warranty

Harbor Freight Tools Co. makes every effort to assure that its products meet high quality and durability standards, and warrants to the original purchaser that this product is free from defects in materials and workmanship for the period of 90 days from the date of purchase. This warranty does not apply to damage due directly or indirectly, to misuse, abuse, negligence or accidents, repairs or alterations outside our facilities, criminal activity, improper installation, normal wear and tear, or to lack of maintenance. We shall in no event be liable for death, injuries to persons or property, or for incidental, contingent, special or consequential damages arising from the use of our product. Some states do not allow the exclusion or limitation of incidental or consequential damages, so the above limitation of exclusion may not apply to you. **THIS WARRANTY IS EXPRESSLY IN LIEU OF ALL OTHER WARRANTIES, EXPRESS OR IMPLIED, INCLUDING THE WARRANTIES OF MERCHANTABILITY AND FITNESS.**

To take advantage of this warranty, the product or part must be returned to us with transportation charges prepaid. Proof of purchase date and an explanation of the complaint must accompany the merchandise. If our inspection verifies the defect, we will either repair or replace the product at our election or we may elect to refund the purchase price if we cannot readily and quickly provide you with a replacement. We will return repaired products at our expense, but if we determine there is no defect, or that the defect resulted from causes not within the scope of our warranty, then you must bear the cost of returning the product.

This warranty gives you specific legal rights and you may also have other rights which vary from state to state.

