

Owner's Manual & Safety Instructions

Save This Manual Keep this manual for the safety warnings and precautions, assembly, operating, inspection, maintenance and cleaning procedures. Write the product's serial number in the back of the manual near the assembly diagram (or month and year of purchase if product has no number). Keep this manual and the receipt in a safe and dry place for future reference.

21d

PITTSBURGH[®] AUTOMOTIVE

69686

Portable Tire Changer



Visit our website at: <http://www.harborfreight.com>
Email our technical support at: productsupport@harborfreight.com

When unpacking, make sure that the product is intact and undamaged. If any parts are missing or broken, please call 1-888-866-5797 as soon as possible.

⚠ WARNING

Read this material before using this product. Failure to do so can result in serious injury. SAVE THIS MANUAL.

Copyright© 2021 by Harbor Freight Tools®. All rights reserved.
No portion of this manual or any artwork contained herein may be reproduced in any shape or form without the express written consent of Harbor Freight Tools. Diagrams within this manual may not be drawn proportionally. Due to continuing improvements, actual product may differ slightly from the product described herein. Tools required for assembly and service may not be included.

Specifications

Tire Capacity	All tires from 8 IN. to Light Truck Tires (7-1/2 IN. x 16 IN.) Flotation Tires: Up to 12.5L16
Includes	1 Bead Breaker Handle 37 IN. Long Mount/ Demount Tool

IMPORTANT SAFETY INFORMATION

1. **Do not exceed max. tire capacities.** Do not use on standard tires exceeding 16" or on flotation tire exceeding size 12.5L16.
2. **CAUTION!** Do not use on tires with high-end rims. Tire removal and installation can result in scratches and slight marring on rims.
3. Wear ANSI-approved safety goggles and heavy-duty work gloves during assembly, mounting and use.
4. Do not modify Tire Changer to perform tasks for which it was not designed.
5. Use only with accessories included with the Tire Changer.
6. Do not use without mounting to floor. Mount only to a secure, level surface able to support weight of Manual Tire Changer and tire assembly.
7. Verify that mounting surface has no hidden utility lines before drilling or driving screws.
8. Deflate tire before use. Keep tire's valve stem uncovered during use to allow any remaining air to flow out of tire.
9. Lubricate Breaker Handle (7) when removing tire from rim; failure do so can lead to tire damage.
10. Keep work area clean and well lit.
11. Keep bystanders out of the area during use.
12. Do not use when tired or when under the influence of drugs, medication or alcohol.
13. This product is not a toy. Do not allow children to play with or near this item.
14. Inspect before every use; do not use if parts are loose or damaged.
15. Maintain product labels and nameplates. These carry important safety information. If unreadable or missing, contact Harbor Freight Tools for a replacement.

Assembly/Mounting Instructions



Read the **ENTIRE IMPORTANT SAFETY INFORMATION** section at the beginning of this document including all text under subheadings therein before set up or use of this product.

1. The Tire Changer will require some assembly after unpacking. See the assembly components in Figure 1, below.

NOTE: Assembly of the Base units (9, 13) to the Center Post (1) will be easier if done on a worktable.

2. Set the bottom of the Center Post diagonally across the middle of the Post Base. See Figure 2, below

NOTE: Make sure to align the Center Post with the Post Base so that the Center Post's bracket faces the longer end of the Post Base.

3. Fasten Center Post and Post Base together using the Hex Bolts (6), Washers (11), and Nuts (12). See Figure 2, below.

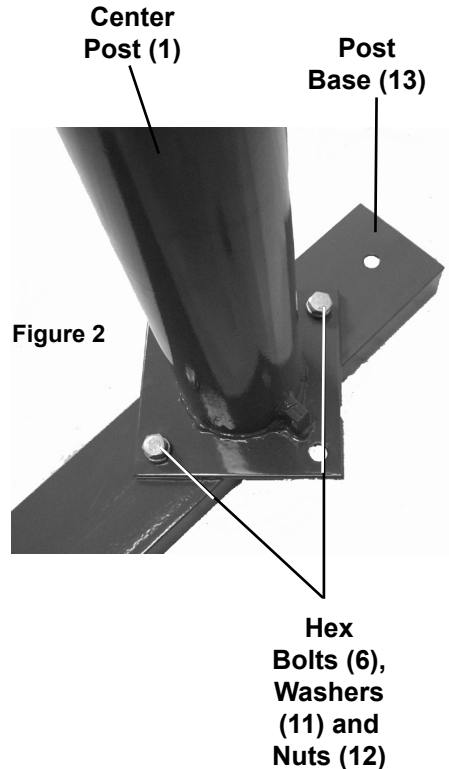
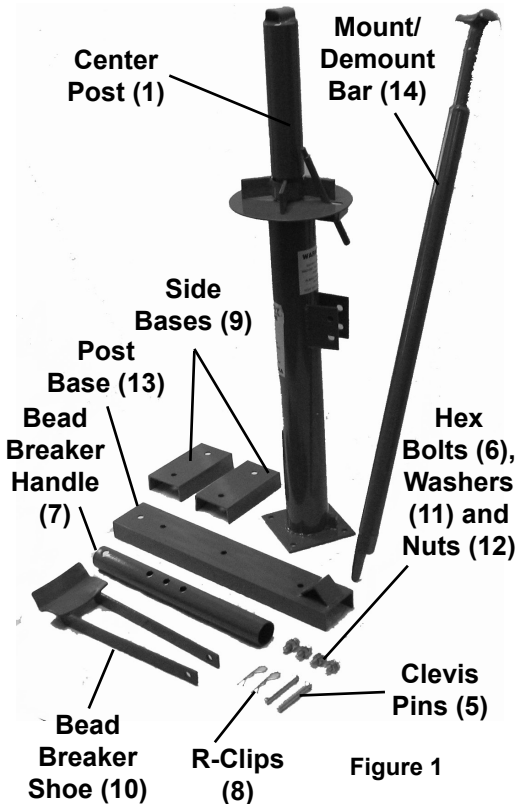

- Set each of the Side Bases (9) along either side of the Post Base until the holes align. Fasten together using the Hex Bolts (6), Washers (11), and Nuts (12). See Figure 3, below.

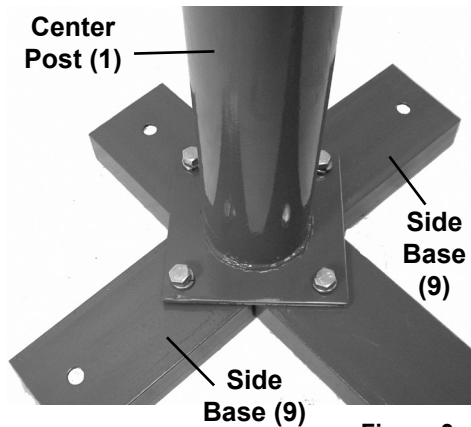

Figure 3

- At this point, the assembled base should be mounted to the selected floor surface (such as a wood pallet or concrete floor) using the 7/16 IN. mounting holes at the ends of the Side Bases and the Post Base.

NOTE: The floor surface should be at least 4 IN. in depth.

- With assistance, move the Tire Changer to the selected location. Use the four 7/16 IN. mounting holes as templates to mark four 7/16 IN. holes on the mounting surface.

NOTE: If mounting to a concrete surface, do not use a concrete drill bit larger in diameter than 7/16 IN.

- Drill four holes in the floor surface equal to the length of four 7/16 IN. diameter anchors (not included) to secure the Tire Changer.
- Set the Tire Changer back on the floor surface and align its four mounting holes at its base with the four pre-drilled holes in the floor surface.
- If necessary, level the Tire Changer on the floor surface using a carpenter's level and steel shims (neither included).
- Use a hammer (not included) to tap the four anchors through the four mounting holes in the base of the Tire Changer and into the floor surface. Continue tapping the anchors until their washers rest against the base of the Tire Changer.
- Firmly tighten the nuts of the four anchors to secure the Tire Changer to the floor surface.
- Place the end of the Bead Breaker Handle (7) in the bracket on the side of the Center Post until the hole on the Handle's end aligns with top or bottom holes of the bracket (depending on the size of the tire.)
- Slide a Clevis Pin (5) through the bracket and Bead Breaker Handle, securing it using the R-Clip (8). See Figure 4, below.

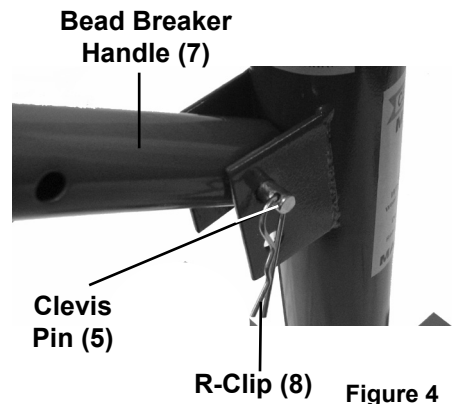

Figure 4

14. Slide the end slots of Bead Breaker Shoe (10) over the mounting holes along the middle of the Bead Breaker Handle. Align with the end or middle holes (depending on which tire size, the closest hole to the Center Post being for smaller tires). Secure in place using the other Clevis Pin and R-Clip. See Figure 5, below.

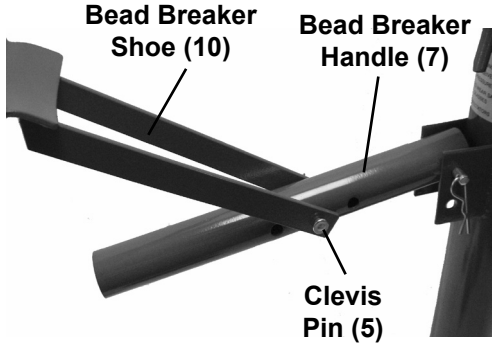

Figure 5

15. Once fully assembled and mounted to the floor, the assembled Tire Changer will look as it does in Figure 6, below.

NOTE: Tire is not included.



Figure 6

Operation

Breaking the Tire Bead

1. Once the tire is deflated, apply bead oil (not included) to tire bead.

NOTE: Tire removal and installation will be much easier when using bead oil.

2. Set Tire down on the longer end of the Post Base (the end with the mounting tab). Position the tire so that the rim is set against the mounting tab, which will keep the tire in place.

NOTE: Make sure the tire's valve stems is facing up.

3. Set the Bead Breaker Shoe against the edge of tire rim. See Figure 7, below.
4. Insert Mounting/Demounting Bar into Bead Breaker Handle. Once inserted, push down on Bead Breaker Handle, allowing the Bead Breaker Shoe to lift tire bead off of rim. See Figure 7, below.

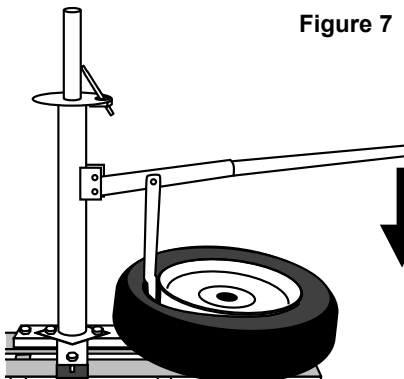

Figure 7

5. Lift Bead Breaker Handle up and slide tire around so that Bead Breaker Shoe can be set against the opposite end of rim.
6. Set the Bead Breaker Shoe against the edge of tire rim. Push down on Bead Breaker Handle, allowing the Bead Breaker Shoe to lift other end of tire bead off of rim.

7. Lift Bead Breaker Handle up, flip tire over and reposition tire against mounting tab.
8. Set Bead Breaker Shoe against the edge of tire rim and push down on Bead Breaker Handle, removing bead from rim. See Figure 8, below.

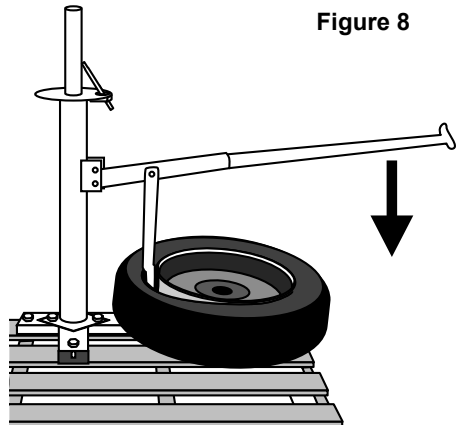
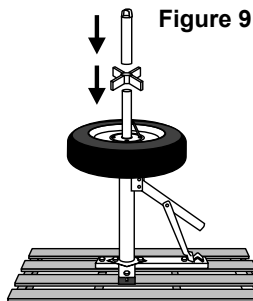

Figure 8

9. Raise Bead Breaker Shoe and slide tire around. Push down on Bead Breaker Handle, removing bead from rim.
 10. Lift Bead Handle up and remove tire from Post Base.
 11. Remove Post Cap (2) and Spider Post (4) from top of Center Post.
 12. Set tire onto the Center Post.
- NOTE:** Make sure tire's valve stem is facing up and Lug Pin (3) is sticking up through lug hole of rim.
13. Thread Spider Post over Center Post with tapered side going into wheel hub. See Figure 9, below.

14. Thread Post Cap onto Center Post. This will tighten Spider Post, locking tire into place. See Figure 9, below.



15. To tighten Post Cap, place flat end of Mount/Demount Bar through top of Post Cap and pull on Mount/Demount Bar. See Figure 10, below.

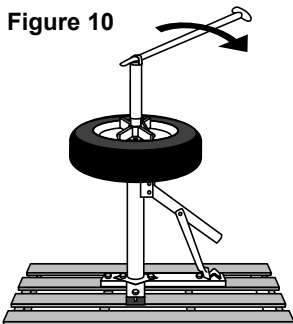

16. Remove Mount/Demount Bar from Post Cap and set end against bead. Push down on Bar, forcing bead away from rim.
17. Slide bar down and, using the Post Cap as leverage, pull the Bar around, continuing to separate the bead from rim. See Figure 11, below.

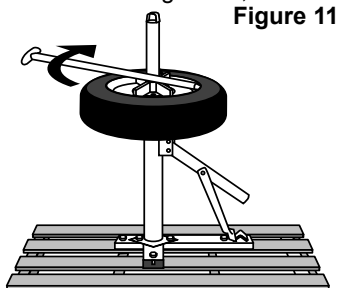

18. Once bead on outer side of tire is separated from rim, pull tire up with free hand and push Bar down so it is against bead on inner rim. See Figure 12, below.

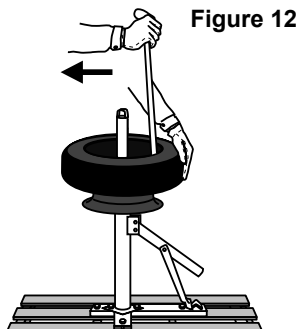

19. Using Post Cap as leverage, pull Bar around, separating inner bead from tire rim.

NOTE: You may need to hold onto Post Cap with your free hand for added leverage. See Figure 13, below.

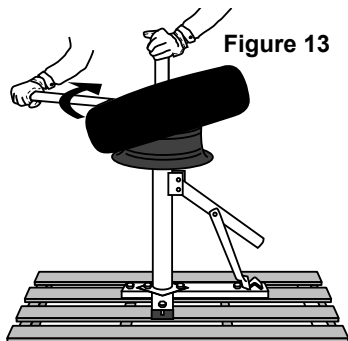

20. Continue pulling Bar around tire until bead is fully separated from rim. Then lift tire off of Center Post.
21. If desired, unthread Post Cap and Spider Post and remove rim from Tire Changer.

Mounting Tire Onto Rim

1. Set rim on Center Post and lock into place using the Spider Post and Post Cap (if not already done).
2. Set tire on rim and push down on opposite ends of the tire. See Figure 14, below.

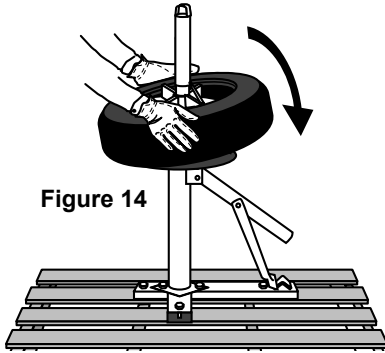

Figure 14

NOTE: Be sure to apply bead lubricant before tire mounting.

3. Stick Mounting/Demounting Bar through tire (with flat edge facing down) to help wedge bead back behind rim.
4. Push down on tire with free hand as you work bead behind rim. If needed push Bar along Center Post for added leverage. See Figure 15, below.

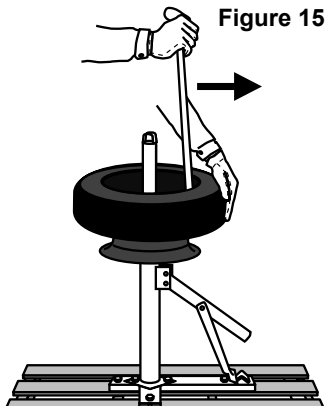

Figure 15

5. Once inner side of tire is mounted to rim, push down on tire again until one side of outer bead is under rim.
6. Remove Bar and switch ends, so that hook side is pressed against bead.
7. Push Bar down so that hook end wedges bead under rim. See Figure 16, below.

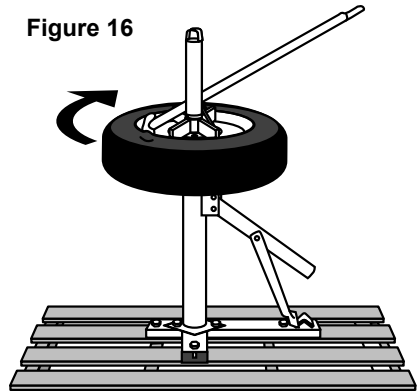

Figure 16

NOTE: Be sure to apply more bead lubricant, if needed.

8. Continue to work around rim until tire mounts over edge of bead.

IMPORTANT: If tire bead starts to seat during mounting, the tire will need to stretch more and will be more difficult to mount. To prevent this, push down on tire with your free hand so it doesn't seat on the upper edge of rim during mounting.

- Depending on the flexibility of rubber (and the amount of bead lubricant used), you may not to switch the Bar around and use the flat edge of Bar to wedge the last sections of the bead under the rim. See Figure 17, below.

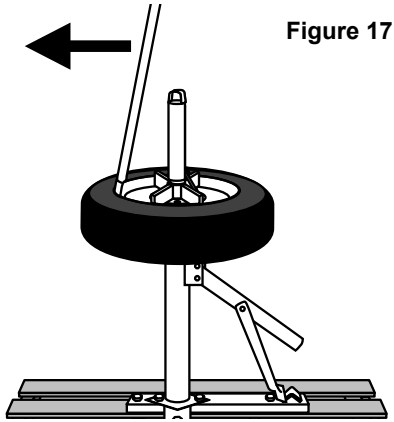

- WARNING!** Do not use the bar to hammer on the side of the tire during mounting. Doing so can damage the tire.
- Once tire is properly mounted onto the rim, inflate tire to the PSI recommended in tire's owner manual. **WARNING! TO PREVENT SERIOUS INJURY:** Do not over-inflate tire.
- WARNING!** Check for any leaks and balance tire before putting inflated tire back onto vehicle.

NOTE: This Tire Changer works best with standard sized tires only. For changing smaller tires, use the **Mini-Tire Changer (34552)** that is also available from Harbor Freight Tools.

Maintenance

- After each use, wipe any excess bead oil off of Tire Changer.
- Regularly inspect Tire Changer to ensure that all connections are secure.

Parts List and Diagram

PLEASE READ THE FOLLOWING CAREFULLY

THE MANUFACTURER AND/OR DISTRIBUTOR HAS PROVIDED THE PARTS LIST AND ASSEMBLY DIAGRAM IN THIS MANUAL AS A REFERENCE TOOL ONLY. NEITHER THE MANUFACTURER OR DISTRIBUTOR MAKES ANY REPRESENTATION OR WARRANTY OF ANY KIND TO THE BUYER THAT HE OR SHE IS QUALIFIED TO MAKE ANY REPAIRS TO THE PRODUCT, OR THAT HE OR SHE IS QUALIFIED TO REPLACE ANY PARTS OF THE PRODUCT. IN FACT, THE MANUFACTURER AND/OR DISTRIBUTOR EXPRESSLY STATES THAT ALL REPAIRS AND PARTS REPLACEMENTS SHOULD BE UNDERTAKEN BY CERTIFIED AND LICENSED TECHNICIANS, AND NOT BY THE BUYER. THE BUYER ASSUMES ALL RISK AND LIABILITY ARISING OUT OF HIS OR HER REPAIRS TO THE ORIGINAL PRODUCT OR REPLACEMENT PARTS THERETO, OR ARISING OUT OF HIS OR HER INSTALLATION OF REPLACEMENT PARTS THERETO.

Parts List

Part	Description	Qty.
1	Center Post	1
2	Post Cap	1
3	Lug Pin	1
4	Spider Post	1
5	Clevis Pin (7/16")	2
6	Bolt (3/8" x 16 x 1")	4
7	Bead Breaker Handle	1
8	R-Clip	2
9	Side Base	2
10	Bead Breaker Shoe	1
11	Lock Washer (3/8")	4
12	Nut (3/8" x 16)	4
13	Post Base	1
14	Mount/Demount Bar	1

Record Product's Serial Number Here: _____

Note: If product has no serial number, record month and year of purchase instead.

Note: Some parts are listed and shown for illustration purposes only, and are not available individually as replacement parts. Specify UPC 792363696869 when ordering parts.

Assembly Diagram

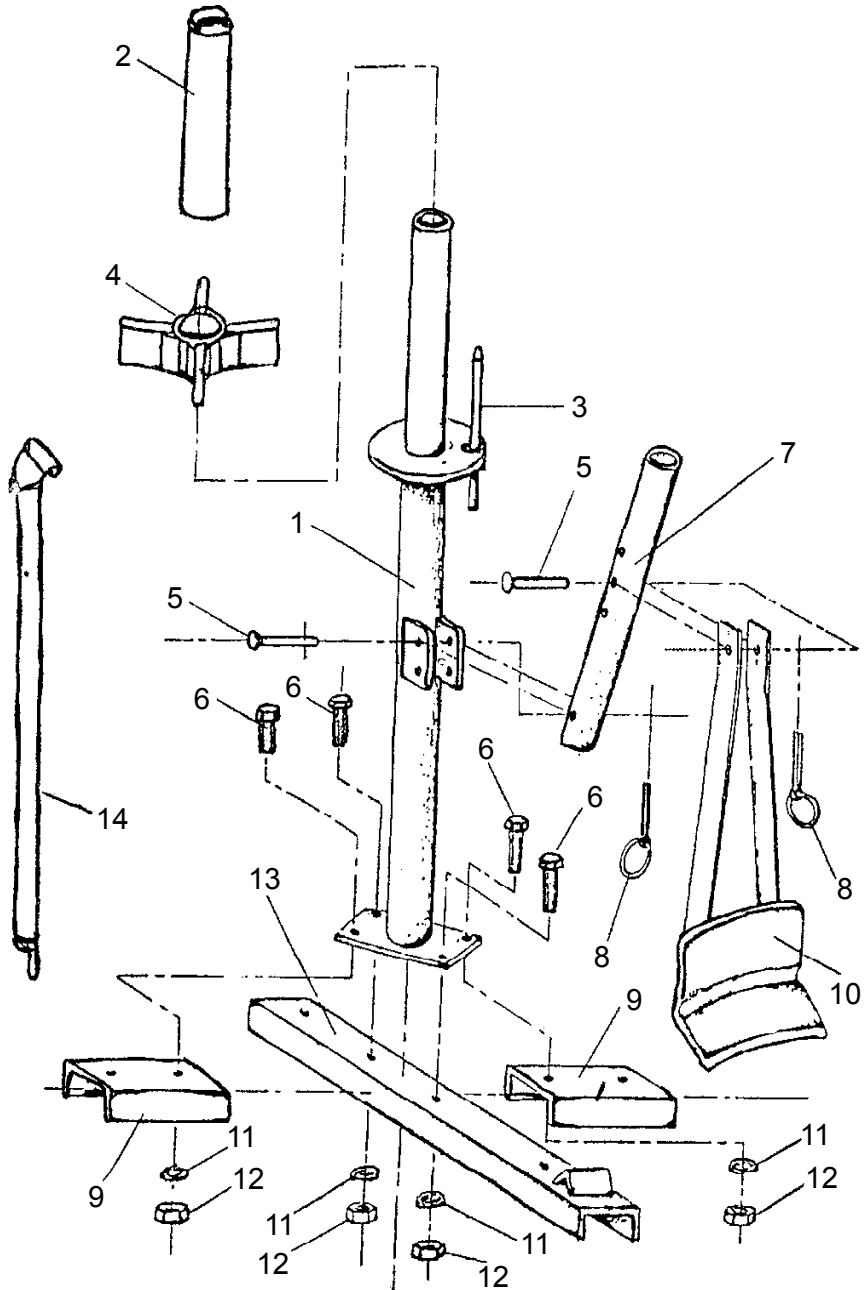

Limited 90 Day Warranty

Harbor Freight Tools Co. makes every effort to assure that its products meet high quality and durability standards, and warrants to the original purchaser that this product is free from defects in materials and workmanship for the period of 90 days from the date of purchase. This warranty does not apply to damage due directly or indirectly, to misuse, abuse, negligence or accidents, repairs or alterations outside our facilities, criminal activity, improper installation, normal wear and tear, or to lack of maintenance. We shall in no event be liable for death, injuries to persons or property, or for incidental, contingent, special or consequential damages arising from the use of our product. Some states do not allow the exclusion or limitation of incidental or consequential damages, so the above limitation of exclusion may not apply to you. THIS WARRANTY IS EXPRESSLY IN LIEU OF ALL OTHER WARRANTIES, EXPRESS OR IMPLIED, INCLUDING THE WARRANTIES OF MERCHANTABILITY AND FITNESS.

To take advantage of this warranty, the product or part must be returned to us with transportation charges prepaid. Proof of purchase date and an explanation of the complaint must accompany the merchandise. If our inspection verifies the defect, we will either repair or replace the product at our election or we may elect to refund the purchase price if we cannot readily and quickly provide you with a replacement. We will return repaired products at our expense, but if we determine there is no defect, or that the defect resulted from causes not within the scope of our warranty, then you must bear the cost of returning the product.

This warranty gives you specific legal rights and you may also have other rights which vary from state to state.

PITTSBURGH[®] AUTOMOTIVE

26541 Agoura Road • Calabasas, CA 91302 • 1-888-866-5797