

Owner's Manual & Safety Instructions

Save This Manual Keep this manual for the safety warnings and precautions, assembly, operating, inspection, maintenance and cleaning procedures. Write the product's serial number in the back of the manual near the assembly diagram (or month and year of purchase if product has no number). Keep this manual and the receipt in a safe and dry place for future reference.

21a

HaulMaster®

2000 LB.

TRAILER JACK



Visit our website at: <http://www.harborfreight.com>
Email our technical support at: productsupport@harborfreight.com

69782

When unpacking, make sure that the product is intact and undamaged. If any parts are missing or broken, please call 1-888-866-5797 as soon as possible.

Copyright© 2020 by Harbor Freight Tools®. All rights reserved.
No portion of this manual or any artwork contained herein may be reproduced in any shape or form without the express written consent of Harbor Freight Tools. Diagrams within this manual may not be drawn proportionally. Due to continuing improvements, actual product may differ slightly from the product described herein.
Tools required for assembly and service may not be included.

⚠️ WARNING

Read this material before using this product.
Failure to do so can result in serious injury.
SAVE THIS MANUAL.

Table of Contents

Safety	2	Maintenance	6
Specifications	3	Parts List and Assembly Diagram.....	7
Installation	4	Warranty	8
Operation.....	5		



WARNING SYMBOLS AND DEFINITIONS

	This is the safety alert symbol. It is used to alert you to potential personal injury hazards. Obey all safety messages that follow this symbol to avoid possible injury or death.
	Indicates a hazardous situation which, if not avoided, will result in death or serious injury.
	Indicates a hazardous situation which, if not avoided, could result in death or serious injury.
	Indicates a hazardous situation which, if not avoided, could result in minor or moderate injury.
	Addresses practices not related to personal injury.

IMPORTANT SAFETY INFORMATION

WARNING

Read all safety warnings and instructions.
Failure to follow the warnings and instructions may result in serious injury.
Save all warnings and instructions for future reference.

Basic Safety Information

Keep work area clean and well lit.
Cluttered or dark areas invite accidents.

Personal safety

- Stay alert, watch what you are doing and use common sense when operating a tool. Do not use a tool while you are tired or under the influence of drugs, alcohol or medication.**
A moment of inattention while operating tools may result in serious personal injury.
- Use personal protective equipment. Always wear eye protection.** *Safety equipment such as non-skid safety shoes or a hard hat used for appropriate conditions will reduce personal injuries.*

Service

Have your tool serviced by a qualified repair person using only identical replacement parts. *This will ensure that the safety of the tool is maintained.*

Specific Safety Warnings

1. Mounting bracket must be attached by certified welder.
2. Do not exceed rated capacity.
3. Lock Trailer Jack in vertical position before applying load.
4. Use on flat, level, hard surface capable of supporting load.
5. Wear ANSI-approved safety goggles during use.
6. Prevent trailer wheels from moving using wheel chocks while raising or lowering.
7. Before towing, fully raise trailer jack and secure properly in its horizontal position, or remove it.
8. Keep out from under jack and tongue when applying and releasing load, or moving trailer.
9. Inspect before use. Do not use if parts are loose or damaged.
10. Use in accordance with the Department of Transportation (DOT) regulations.
11. Maintain labels and nameplates on the tool. These carry important safety information. If unreadable or missing, contact Harbor Freight Tools for a replacement.
12. Do not use blocks for additional ground clearance.
13. Apply force to jack vertically only. Side forces will compromise the jack.
14. Do not climb aboard any vehicle supported by jack.
15. This product is not a toy. Keep it out of reach of children.
16. Follow all state regulations for boat safety and towing when using Trailer Jack, including using safety chains securely attached to the towing vehicle when the trailer is hooked to the vehicle.
17. Not for aircraft purposes.
18. Trailer Jack must always be in the folded up position (horizontal to ground), or removed, when towing the trailer.
19. The warnings, precautions, and instructions discussed in this instruction manual cannot cover all possible conditions and situations that may occur. It must be understood by the operator that common sense and caution are factors which cannot be built into this product, but must be supplied by the operator.



SAVE THESE INSTRUCTIONS.

Specifications

Rated Capacity	2000 lb.
Height Range	10-1/2" to 20-1/2"
Plate Dimensions	7" x 4"

Installation Instructions



Read the **ENTIRE IMPORTANT SAFETY INFORMATION** section at the beginning of this manual including all text under subheadings therein before set up or use of this product.

Note: For additional information regarding the parts listed in the following pages, refer to *Parts List and Assembly Diagram* on page 6.

Components

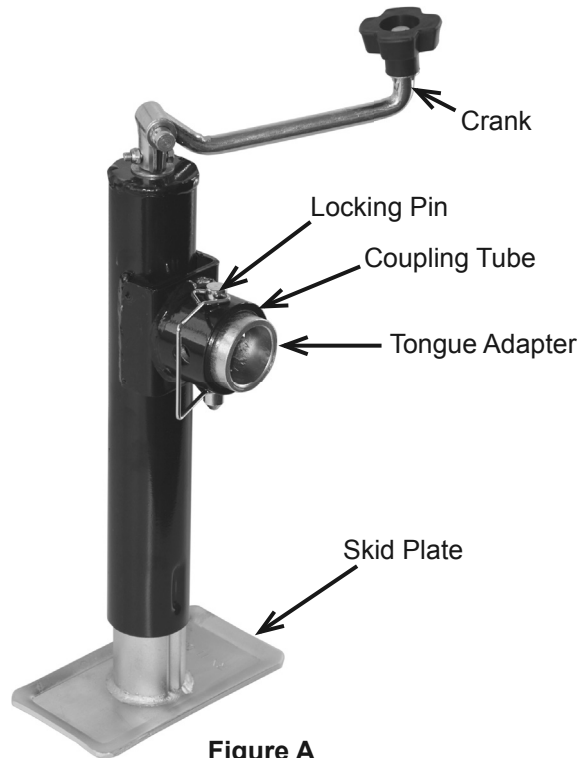

Figure A

Mounting

WARNING! The Trailer Jack Tongue Adapter must be welded in place by a qualified and certified welder. A poor weld may cause the trailer to fall suddenly, causing serious personal injury or property damage.

1. Measure the trailer tongue for the best location to mount the Jack. With the trailer mounted on the towing vehicle hitch, consider the following:
 - a. Allow room on both sides of the mounting location for the Jack to swing up to its horizontal position.
 - b. Check that the Jack will not interfere with the Vehicle or trailer when turning or passing over speed bumps, boat ramps, etc.
 - c. To prevent overloading the Jack, attach it as near to the coupler as is practical.
 2. Once the location is determined, remove the Tongue Adapter from the Jack by pulling the Locking Pin from the Coupling Tube and pulling out the Tongue Adapter.
 3. Position the Tongue adapter so that the holes will line up with the Coupling Tube holes when the Jack is in use, then weld the Tongue Adapter to the trailer tongue.
- CAUTION!** Position the Tongue Adapter holes so the Jack is stable and vertical for use.
4. Raise the Jack so that the Coupling Tube is level with the welded Tongue Adapter, and attach the Trailer Jack by fitting the Coupling Tube over the Tongue Adapter.
 5. Slide the Locking Pin through the appropriate hole in the Coupling Tube and the Tongue Adapter to secure the Trailer Jack to the trailer tongue.
 6. Test the operation of the Trailer Jack by making sure that the Crank lowers and raises it, and that it locks it into its vertical and horizontal position with the Locking Pin.

Operation Instructions



Read the **ENTIRE IMPORTANT SAFETY INFORMATION** section at the beginning of this manual including all text under subheadings therein before set up or use of this product.

Mount and dismount Trailer only on smooth, level surfaces.

Dismounting The Trailer From The Towing Vehicle

1. Chock the trailer wheels to prevent the trailer from rolling. Set the towing vehicle's transmission in park/neutral, and set its parking brake.
1. With the trailer on the hitch, support the weight of the Jack with one hand and pull the Locking Pin out of the Coupling Tube/Tongue Adapter holes, allowing the Jack to rotate downwards. Keep fingers away from the Coupling Tube/Tongue Adapter area, and feet away from the Skid plate as the Jack swings downward.
2. Replace the Locking Pin into the Coupling Tube/Tongue Adapter, locking the Jack into the lowered position.
3. Rotate the Crank counterclockwise to lower the Skid Plate to the ground. Continue to crank just enough for the Trailer Jack to take the weight of the trailer. This will make it easier to disengage the trailer hitch.
4. Unlatch the trailer hitch. Disengage any safety chains, electrical connections and other connections between the vehicle and the trailer.
5. Continue rotating the crank until the trailer is clear of the hitch ball.
6. When the vehicle is completely clear, and it is safe to do so, drive the vehicle away from the trailer.

CAUTION! Have a spotter watch this operation to be sure the trailer is clear of the vehicle, and does not roll away.

Using The Jack To Mount The Trailer To The Towing Vehicle

Note: If the trailer tongue is too heavy, do not attempt to lift it; seek assistance.

1. Before dismounting, chock the trailer wheels to prevent the Trailer from rolling.
2. Move the towing vehicle in place so that the vehicle's hitch is in close proximity to the trailer's hitch.
3. If the trailer tongue is resting on the ground:
 - a. Support the weight of the Jack with one hand and pull the Locking Pin out of the Coupling Tube/Tongue Adapter, allowing the Jack to rotate downwards. Keep fingers away from the Coupling Tube/Tongue Adapter area, and feet away from the Skid plate as the Jack swings downward.
 - b. Lift the trailer tongue, while the Jack rotates into the lowered position.
 - c. When the holes align, insert the Locking Pin into the Coupling Tube/Tongue Adapter holes, locking the Jack into the lowered position.
4. Rotate the Crank to raise or lower the trailer to the level of the towing vehicle's hitch.
5. Have an assistant spot as you move the vehicle in close to the trailer's hitch. Mount the trailer onto the towing vehicle's hitch.
6. Turn the Crank Handle clockwise to lower the Jack slightly, transferring the trailer's weight onto the towing vehicle and to clear the Skid Plate from the ground.
7. Pull out the Locking Pin, and rotate the Jack into its horizontal position, then reinsert the Locking Pin.

Note: If preferred, the Jack and its pin can simply be removed and stored during transport.

8. Check all connections and remove wheel chocks before driving the vehicle.

Inspection, Testing, and Maintenance



Procedures not specifically explained in this manual must be performed only by a qualified technician.

WARNING

TO PREVENT SERIOUS INJURY:

Remove Jack from trailer before performing any inspection, maintenance, or cleaning procedures.

TO PREVENT SERIOUS INJURY FROM TOOL FAILURE:

Do not use damaged equipment. If abnormal noise or vibration occurs, have the problem corrected before further use.

Cleaning, Maintenance, and Lubrication

1. **BEFORE EACH USE**, inspect the general condition of the tool. Check for:
 - loose hardware,
 - misalignment or binding of moving parts,
 - cracked or broken parts, and
 - any other condition that may affect its safe operation.
2. Keep the Crank mechanism and Inner Tube lightly greased.
3. **AFTER USE**, wipe external surfaces of the tool with clean cloth.

Parts List and Assembly Diagram

PLEASE READ THE FOLLOWING CAREFULLY

THE MANUFACTURER AND/OR DISTRIBUTOR HAS PROVIDED THE PARTS LIST AND ASSEMBLY DIAGRAM IN THIS MANUAL AS A REFERENCE TOOL ONLY. NEITHER THE MANUFACTURER OR DISTRIBUTOR MAKES ANY REPRESENTATION OR WARRANTY OF ANY KIND TO THE BUYER THAT HE OR SHE IS QUALIFIED TO MAKE ANY REPAIRS TO THE PRODUCT, OR THAT HE OR SHE IS QUALIFIED TO REPLACE ANY PARTS OF THE PRODUCT. IN FACT, THE MANUFACTURER AND/OR DISTRIBUTOR EXPRESSLY STATES THAT ALL REPAIRS AND PARTS REPLACEMENTS SHOULD BE UNDERTAKEN BY CERTIFIED AND LICENSED TECHNICIANS, AND NOT BY THE BUYER. THE BUYER ASSUMES ALL RISK AND LIABILITY ARISING OUT OF HIS OR HER REPAIRS TO THE ORIGINAL PRODUCT OR REPLACEMENT PARTS THERETO, OR ARISING OUT OF HIS OR HER INSTALLATION OF REPLACEMENT PARTS THERETO.

Part	Description	Qty
1	Crank	1
2	Bolt M6x28	1
3	Lock Nut M6	1
4	Washer	1
5	Chain	1
6	Locking Pin	1
7	Chain Rivet	1

Part	Description	Qty
8	Tongue Adapter	1
9	Outer Tube Assembly	1
10	Bearing	1
11	Washer	1
12	Thread	1
13	Nut	1
14	Inner Tube	1

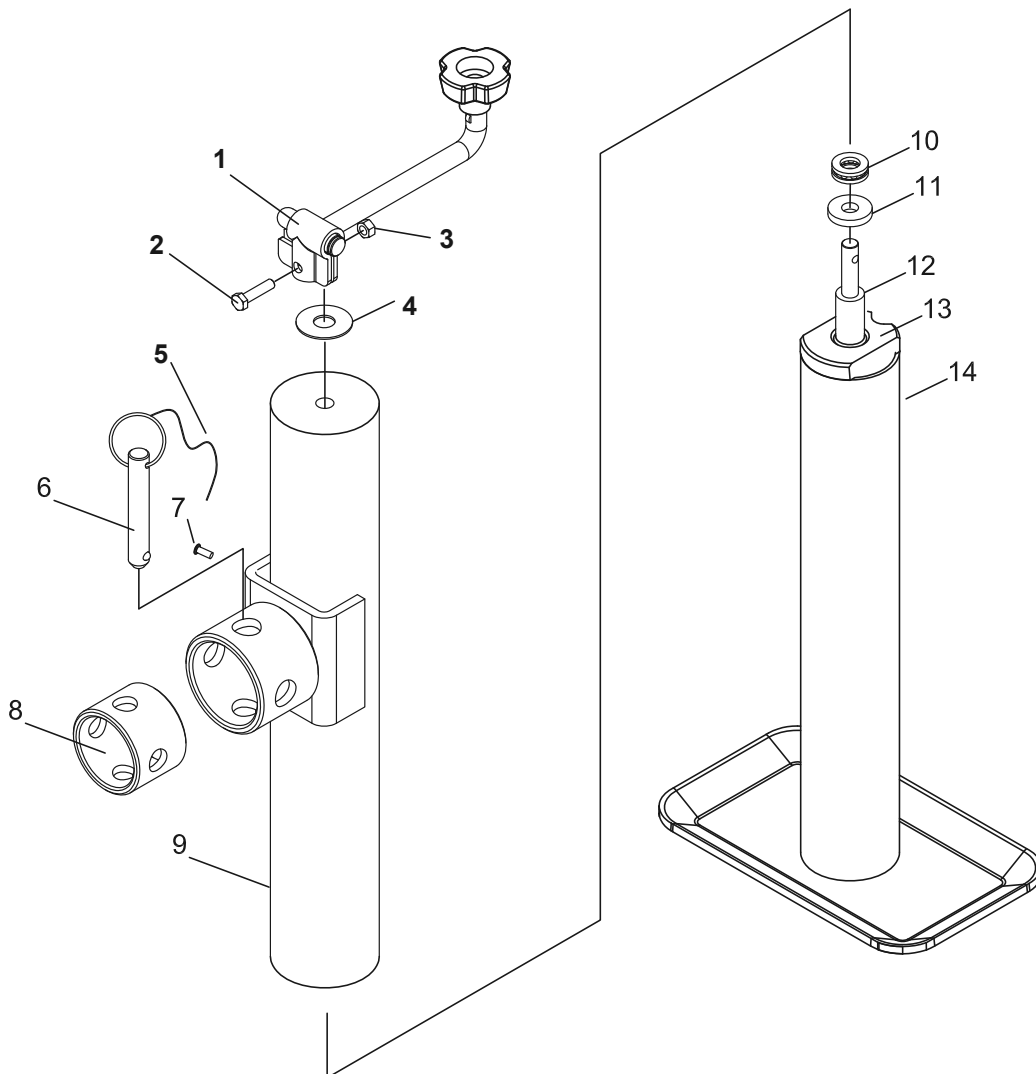

Record Product's Serial Number Here: _____

Note: If product has no serial number, record month and year of purchase instead.

Note: Some parts are listed and shown for illustration purposes only, and are not available individually as replacement parts. Specify UPC 792363697828 when ordering parts.

Limited 90 Day Warranty

Harbor Freight Tools Co. makes every effort to assure that its products meet high quality and durability standards, and warrants to the original purchaser that this product is free from defects in materials and workmanship for the period of 90 days from the date of purchase. This warranty does not apply to damage due directly or indirectly, to misuse, abuse, negligence or accidents, repairs or alterations outside our facilities, criminal activity, improper installation, normal wear and tear, or to lack of maintenance. We shall in no event be liable for death, injuries to persons or property, or for incidental, contingent, special or consequential damages arising from the use of our product. Some states do not allow the exclusion or limitation of incidental or consequential damages, so the above limitation of exclusion may not apply to you. THIS WARRANTY IS EXPRESSLY IN LIEU OF ALL OTHER WARRANTIES, EXPRESS OR IMPLIED, INCLUDING THE WARRANTIES OF MERCHANTABILITY AND FITNESS.

To take advantage of this warranty, the product or part must be returned to us with transportation charges prepaid. Proof of purchase date and an explanation of the complaint must accompany the merchandise. If our inspection verifies the defect, we will either repair or replace the product at our election or we may elect to refund the purchase price if we cannot readily and quickly provide you with a replacement. We will return repaired products at our expense, but if we determine there is no defect, or that the defect resulted from causes not within the scope of our warranty, then you must bear the cost of returning the product.

This warranty gives you specific legal rights and you may also have other rights which vary from state to state.



26541 Agoura Road • Calabasas, CA 91302 • 1-888-866-5797