



3" Swivel Vise

Item 7421

⚠ WARNING

Read this material before using this product.
Failure to do so can result in serious injury.
SAVE THIS MANUAL.

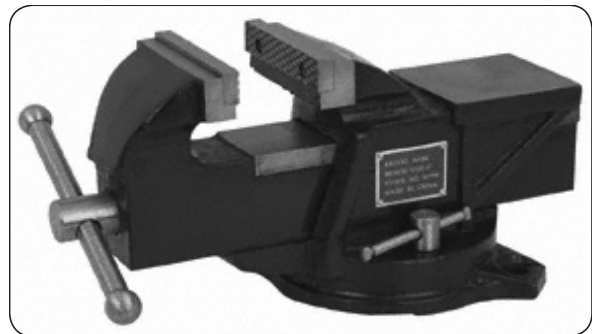

When unpacking, make sure that the product is intact and undamaged.
If any parts are missing or broken, please call 1-800-444-3353 as soon as possible.

Visit our website at: <http://www.harborfreight.com>

Email our technical support at: tech@harborfreight.com

SAVE THIS MANUAL

You will need the manual for the safety warnings and precautions, operating and maintenance procedures, parts list and diagram. Keep your invoice with this manual. Write the invoice number on the inside of the front cover. Keep the manual and invoice in a safe and dry place for future reference.

IMPORTANT SAFETY INFORMATION

1. Mount only according to these instructions. Improper mounting can create hazards.
2. Keep work area clean and well lit.
3. Keep bystanders out of the area during use.
4. This product is not a toy. Do not allow children to play with or near this item.
5. Use for intended purposes only.
6. Inspect before use; do not use if parts are loose or damaged.
7. Maintain product labels and nameplates. These carry important safety information. If unreadable or missing, contact Harbor Freight Tools for a replacement.
8. Before drilling holes, check for hidden utility lines in drilling path.
9. **DO NOT USE THIS PRODUCT IF UNDER THE INFLUENCE OF MEDICATION, ALCOHOL OR DRUGS.** Read warning labels on prescriptions to determine if your judgement or reflexes are impaired while taking drugs. If there is any doubt, do not use this product.
10. **USE EYE AND HAND PROTECTION.** Wear ANSI-approved safety impact goggles and heavy-duty work gloves during use.
11. **DRESS SAFELY.** Do not wear loose clothing or jewelry as they can become caught in moving parts. Wear a protective hair covering to prevent long hair from becoming caught in the moving parts.

12. **WHEN WORKING WITH THE ANVIL (6), DO NOT STRIKE WITH A HARDENED TOOL.** It could chip the Anvil and/or the tool.
13. **DO NOT OVERREACH.** Keep proper footing and balance at all times.
14. **STAY ALERT.** Watch what you are doing at all times. Use common sense. Do not operate this product when you are tired.
15. Damage could occur to your vise and/or workpiece if you overtighten the Handle (5).
16. **CHECK FOR DAMAGED PARTS.** Before using this product, carefully check that it will operate properly and perform its intended function. Check for damaged parts and any other conditions that may affect its operation. Replace or repair damaged or worn parts immediately.
17. **REPLACEMENT PARTS AND ACCESSORIES.** When servicing, use only identical replacement parts.
18. **MAINTAIN PRODUCT WITH CARE.** Keep this product clean and dry, and moving parts lightly lubricated for better performance. Keep the Handle dry, clean and free from oil, grease, and solvents.
19. **USE THE RIGHT PRODUCT FOR THE RIGHT JOB.** Do not attempt to force a small tool or attachment to do the work of a larger industrial tool. Do not modify this tool and do not use this tool for any purpose other than which it was intended.



SAVE THESE INSTRUCTIONS.

SPECIFICATIONS

Base	360° Swivel Base
Jaw Opening	2-1/2 IN. Maximum
Anvil Size	2-7/8 IN. L x 2-7/8 IN. W
Base	4-7/8 IN. x 4-7/8 IN.
Overall	10-1/4 IN. L x 4-7/8 IN. W x 5-1/4 IN. H

OPERATING INSTRUCTIONS



Read the **ENTIRE IMPORTANT SAFETY INFORMATION** section at the beginning of this document including all text under subheadings therein before set up or use of this product.

Set-Up:

1. Use the mounting holes on the Vise's Base (1) as a template to mark drill points. Set the Vise flat on the workbench so that the mounting holes are positioned as desired. With a pencil, mark the points at which to fasten the Vise onto the workbench. Set the Vise aside.
2. Drill holes of the appropriate size (where previously marked with a pencil) through the top of the workbench.
3. **NOTE:** There should be minimal clearance between the mounting lugs and the fasteners. Always drill one hole and attach a fastener and tighten. Then drill holes through remaining lugs, attach fasteners, and tighten.

WARNING! Before drilling holes, check for hidden electrical wires or cords in drilling path.

4. Carefully set the Base (1) of the Vise with the Mounting Holes corresponding to the holes previously drilled through the top of the workbench. (See Assembly Diagram on next page.)
5. Insert hardened steel bolts (not provided), of the appropriate diameter (to fit 7/16" diameter mounting holes) and length, downward through the Base (1) and through the workbench. The length of the mounting bolts will be determined by the thickness of the workbench. Secure the mounting bolts in place with the appropriate washers and nuts.
6. Turn the Handle (5) counterclockwise to open the Jaws (2) of the Vise. Place the item you are working on inside the Jaws. Tighten Jaws against the workpiece by turning the Handle clockwise until your workpiece is held securely against the Jaws.

CAUTION: Damage could occur to your vise and/or workpiece if you overtighten the Handle (6).

7. When opening Jaws, do not open beyond 3" to keep Jaw from separating from Anvil.

Swivel the Mounted Vise

By swiveling the Vise around you can access your workpiece easier.

1. Turn the two Locking T-Handles (3) until they release the Swivel Base (4) of the Vise.
2. Turn the Vise to the desired position. (Example: Swivel 180°).
3. Tighten the Locking T-Handles once you have the Vise in the position best suited for your work.

MAINTENANCE

1. Keep the moving parts lubricated. Wipe off any lubricant on the Handles and Jaws.
2. Keep the Jaws clean.
3. The jaws can be removed for cleaning and are replaceable. Each is held on by two 5mm cap screws. Use a 5mm hex wrench (not included) to loosen/tighten the cap screws.
4. Check and tighten the mounting screws or bolts to be sure the vise has not loosened from its mounting.

PLEASE READ THE FOLLOWING CAREFULLY

THE MANUFACTURER AND/OR DISTRIBUTOR HAS PROVIDED THE PARTS LIST AND ASSEMBLY DIAGRAM IN THIS DOCUMENT AS A REFERENCE TOOL ONLY. NEITHER THE MANUFACTURER OR DISTRIBUTOR MAKES ANY REPRESENTATION OR WARRANTY OF ANY KIND TO THE BUYER THAT HE OR SHE IS QUALIFIED TO MAKE ANY REPAIRS TO THE PRODUCT, OR THAT HE OR SHE IS QUALIFIED TO REPLACE ANY PARTS OF THE PRODUCT. IN FACT, THE MANUFACTURER AND/OR DISTRIBUTOR EXPRESSLY STATES THAT ALL REPAIRS AND PARTS REPLACEMENTS SHOULD BE UNDERTAKEN BY CERTIFIED AND LICENSED TECHNICIANS, AND NOT BY THE BUYER. THE BUYER ASSUMES ALL RISK AND LIABILITY ARISING OUT OF HIS OR HER REPAIRS TO THE ORIGINAL PRODUCT OR REPLACEMENT PARTS THERETO, OR ARISING OUT OF HIS OR HER INSTALLATION OF REPLACEMENT PARTS THERETO.

Record Serial Number Here: _____

Note: If product has no serial number, record month and year of purchase instead.

Note: Some parts are listed and shown for illustration purposes only, and are not available individually as replacement parts.

PARTS LIST AND ASSEMBLY DIAGRAM

Part	Description	Qty.
1	Base	1
2	Jaws	2
3	Locking T-Handles	2
4	Swivel Base	1
5	Handle	1
6	Base Nut	1

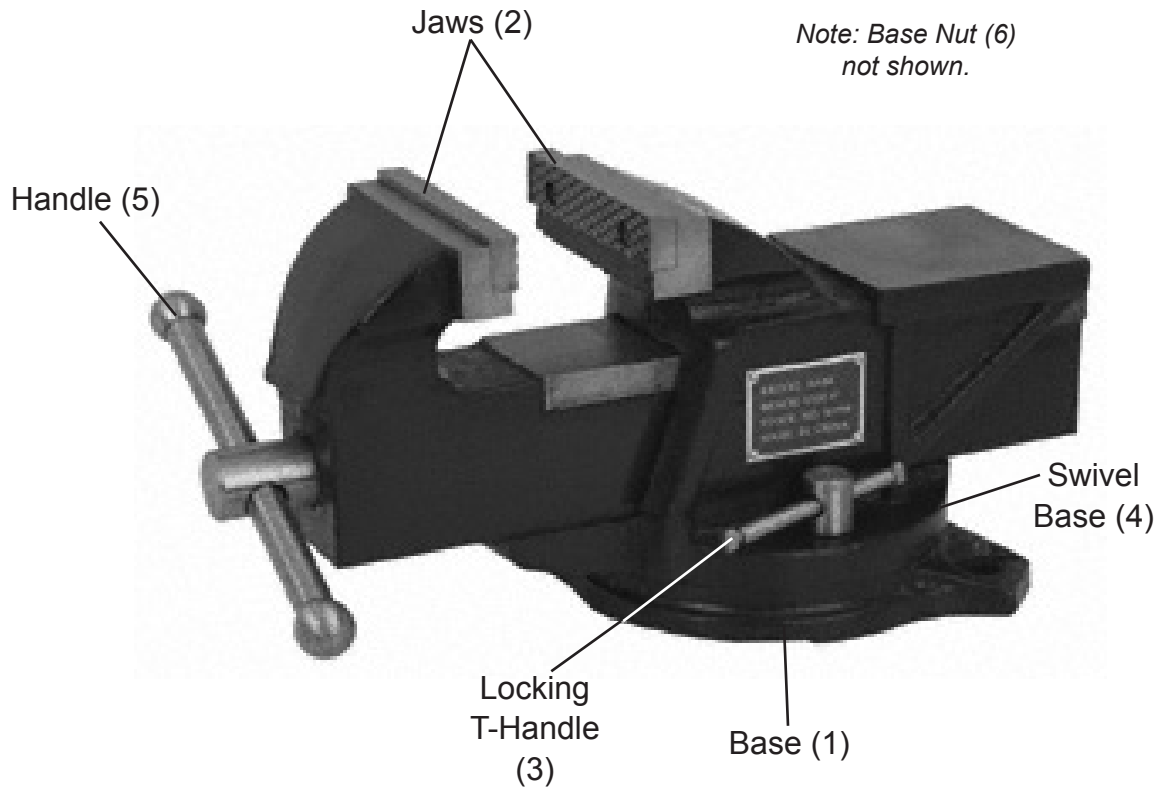

LIMITED 90 DAY WARRANTY

Harbor Freight Tools Co. makes every effort to assure that its products meet high quality and durability standards, and warrants to the original purchaser that this product is free from defects in materials and workmanship for the period of 90 days from the date of purchase. This warranty does not apply to damage due directly or indirectly, to misuse, abuse, negligence or accidents, repairs or alterations outside our facilities, criminal activity, improper installation, normal wear and tear, or to lack of maintenance. We shall in no event be liable for death, injuries to persons or property, or for incidental, contingent, special or consequential damages arising from the use of our product. Some states do not allow the exclusion or limitation of incidental or consequential damages, so the above limitation of exclusion may not apply to you. THIS WARRANTY IS EXPRESSLY IN LIEU OF ALL OTHER WARRANTIES, EXPRESS OR IMPLIED, INCLUDING THE WARRANTIES OF MERCHANTABILITY AND FITNESS.

To take advantage of this warranty, the product or part must be returned to us with transportation charges prepaid. Proof of purchase date and an explanation of the complaint must accompany the merchandise. If our inspection verifies the defect, we will either repair or replace the product at our election or we may elect to refund the purchase price if we cannot readily and quickly provide you with a replacement. We will return repaired products at our expense, but if we determine there is no defect, or that the defect resulted from causes not within the scope of our warranty, then you must bear the cost of returning the product.

This warranty gives you specific legal rights and you may also have other rights which vary from state to state.

3491 Mission Oaks Blvd. • PO Box 6009 • Camarillo, CA 93011 • (800) 444-3353