

Owner's Manual & Safety Instructions

Save This Manual Keep this manual for the safety warnings and precautions, assembly, operating, inspection, maintenance and cleaning procedures. Write the product's serial number in the back of the manual near the assembly diagram (or month and year of purchase if product has no number). Keep this manual and the receipt in a safe and dry place for future reference.

19a

FRANKLIN™

70027

1000 POUND 4-IN-1 HAND TRUCK



Visit our website at: <http://www.harborfreight.com>
Email our technical support at: productsupport@harborfreight.com

When unpacking, make sure that the product is intact and undamaged. If any parts are missing or broken, please call 1-888-866-5797 as soon as possible.

Copyright© 2018 by Harbor Freight Tools®. All rights reserved.
No portion of this manual or any artwork contained herein may be reproduced in any shape or form without the express written consent of Harbor Freight Tools. Diagrams within this manual may not be drawn proportionally. Due to continuing improvements, actual product may differ slightly from the product described herein.
Tools required for assembly and service may not be included.

⚠ WARNING

Read this material before using this product.
Failure to do so can result in serious injury.
SAVE THIS MANUAL.

Specifications

Loading Capacity	45° - 500 lb. Vertical - 800 lb. Horizontal - 1000 lb.
------------------	--

IMPORTANT SAFETY INFORMATION

Assembly Precautions

1. Assemble only according to these instructions. Improper assembly can create hazards.
2. Wear ANSI-approved safety goggles and heavy-duty work gloves during assembly.
3. Keep assembly area clean and well lit.
4. Keep bystanders out of the area during assembly.
5. Do not assemble when tired or when under the influence of alcohol, drugs or medication.
6. Weight capacity and other product capabilities apply to properly and completely assembled product only.

Use Precautions

1. This product is not a toy. Do not allow children to play with or near this item.
2. Use as intended only.
3. Inspect before every use; do not use if parts are loose or damaged.
4. Lock into one of the four operating positions before use.
5. Do not exceed listed weight capacity.
Be aware of dynamic loading!
Sudden load movement may briefly create excess load causing product failure.
6. Strap top-heavy loads to hand truck in vertical position and hold them at all times.
7. Load must be centered over the wheels at all times during movement. If a load's center of gravity is too far away from the edge, it may not be possible to move it safely using a hand truck.
8. Use only on flat, level surface able to support weight of hand truck and load.
9. Maintain product labels and nameplates. These carry important safety information. If unreadable or missing, contact Harbor Freight Tools for a replacement.

Assembly Instructions



Read the **ENTIRE IMPORTANT SAFETY INFORMATION** section at the beginning of this document including all text under subheadings therein before set up or use of this product.

1. Lay Frame Assembly on the ground with Handle facing down.
2. With Nose Plate (1) laying flat, place Nose Plate Extension (6) onto Nose Plate. Make sure holes on both align properly.

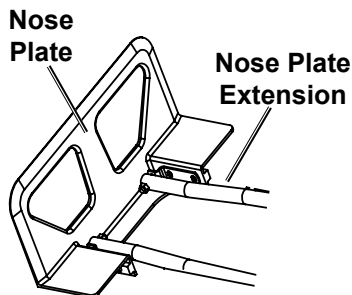

3. Insert a Bolt (20) from the inside pointing outward through each upper hole in the Nose Plate and Nose Plate Extension to act as an alignment tool.
4. Place each Strut (3) against back of Nose Plate and hold Struts in place. Make sure that alignment Bolt threads do not extend past the edge of the Struts.
5. Holding Struts against Nose Plate, slide Nose Plate onto Frame (2). Align holes in Struts and Frame with alignment Bolts and slide alignment Bolts through to hold pieces in place. Make sure the Struts are properly aligned. There should be no Strut holes visible above the Nose Plate.
6. Place a Right Axle Bracket (5) on the outside of the assembly, insert a Bolt through the lower hole from the outside, and secure it in place with a Nut.

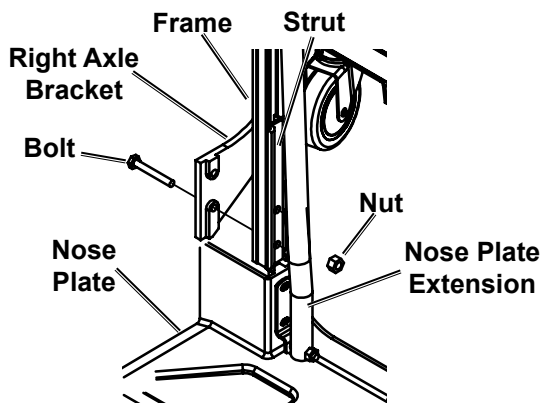

7. Remove the alignment Bolt from the top of the right side, reinsert it through the same hole from the outside, and secure with a Nut.

8. Insert Axle (7) into Right Axle Bracket.

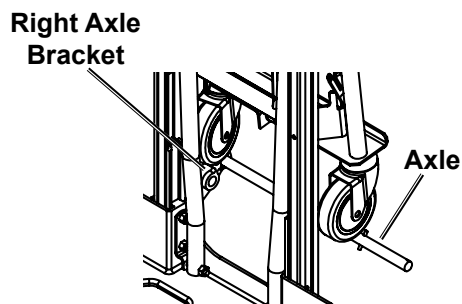

9. Place a Left Axle Bracket (4) on the outside of the assembly, insert a Bolt through the lower hole from the outside, and secure it in place with a Nut.

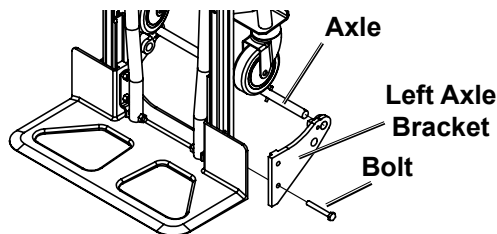

10. Remove the alignment Bolt from the top of the left side, reinsert it through the same hole from the outside, and secure it with a Nut.
11. Place a Washer (22), Spacer (23), Wheel (8), and another Washer onto the Axle.

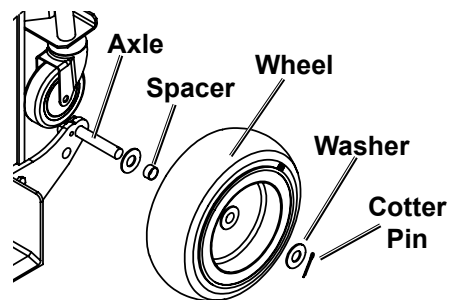

12. Place Cotter Pin (24) through hole at the end of the Axle and bend each end of pin in opposite directions to secure Wheel.



13. Repeat steps 11 and 12 to secure the other Wheel.

Operation Instructions

⚠️ WARNING

Lock into one of the four operating positions before use.

4 Wheel Cart Position

1. Detach Frame from Handle by pulling on the lock ring and then pulling Frame away from Handle.
2. Lower Frame until the Small Handle (13) sits in the groove at the bottom of Handle.

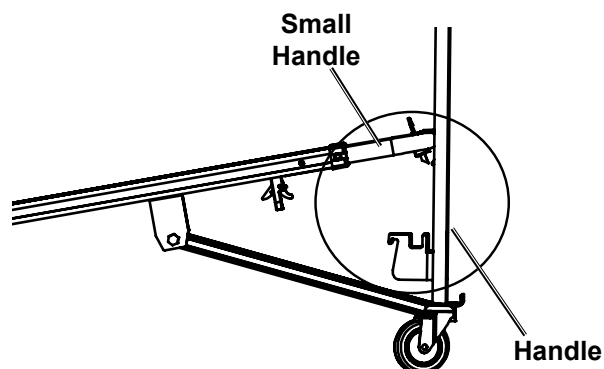
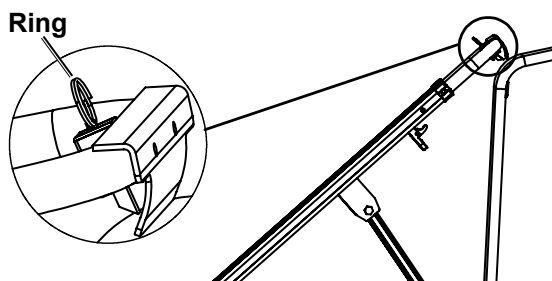

4 Wheel Hand Truck Position

1. Detach Handle from Frame by pressing Latch on the Frame and pulling Handle away from the Frame.
2. Lower the Frame so that the Steel Plate (16) rests on the Handle crossplate. See below.
3. Pull on the lock ring and insert Lock (15) into opening on the Handle crossplate, connecting Frame to Handle. Check that the Frame is connected securely to the Handle.

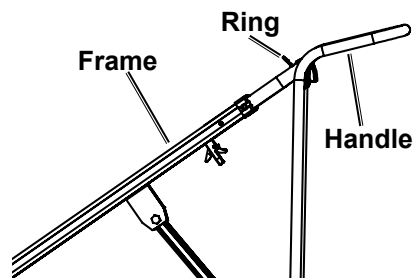
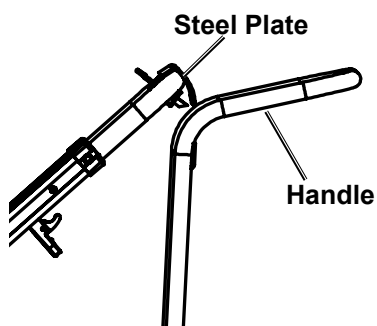

2 Wheel Hand Truck Position

1. Lift Frame (2) until both Frame and Handle (18) stand upright. Connect both hooks at bottom of Handle to Frame.
2. Engage Latch (10) on the Frame completely to the Handle. See illustration.

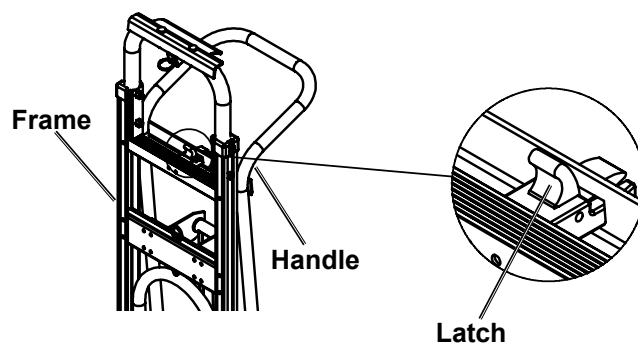

2 Wheel Assisted Hand Truck Position

With Hand Truck in upright position, fold down Nose Plate Extension (6) so that it rests horizontally on Nose Plate (1). See below.

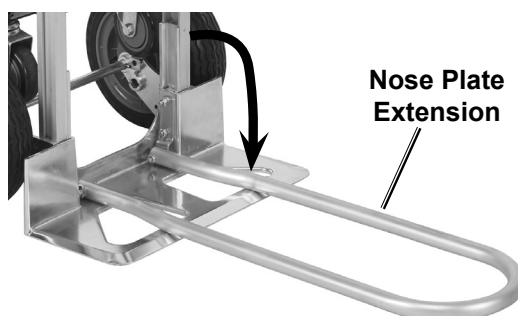

PLEASE READ THE FOLLOWING CAREFULLY

THE MANUFACTURER AND/OR DISTRIBUTOR HAS PROVIDED THE PARTS LIST AND ASSEMBLY DIAGRAM IN THIS DOCUMENT AS A REFERENCE TOOL ONLY. NEITHER THE MANUFACTURER OR DISTRIBUTOR MAKES ANY REPRESENTATION OR WARRANTY OF ANY KIND TO THE BUYER THAT HE OR SHE IS QUALIFIED TO MAKE ANY REPAIRS TO THE PRODUCT, OR THAT HE OR SHE IS QUALIFIED TO REPLACE ANY PARTS OF THE PRODUCT. IN FACT, THE MANUFACTURER AND/OR DISTRIBUTOR EXPRESSLY STATES THAT ALL REPAIRS AND PARTS REPLACEMENTS SHOULD BE UNDERTAKEN BY CERTIFIED AND LICENSED TECHNICIANS, AND NOT BY THE BUYER. THE BUYER ASSUMES ALL RISK AND LIABILITY ARISING OUT OF HIS OR HER REPAIRS TO THE ORIGINAL PRODUCT OR REPLACEMENT PARTS THERETO, OR ARISING OUT OF HIS OR HER INSTALLATION OF REPLACEMENT PARTS THERETO.

Parts List and Diagram

Parts List

Part	Description	Qty
1	Nose Plate	1
2	Frame	1
3	Strut	2
4	Left Axle Bracket	1
5	Right Axle Bracket	1
6	Nose Plate Extension	1
7	Axle	1
8	Wheel	2
9	Right Connected Plate	1
10	Latch	1
11	Left Connected Plate	1
12	End Cap	2
13	Small Handle	1
14	Small Handle Enforcement	2
15	Lock	1

Part	Description	Qty
16	Steel Plate	1
17	Handle Support Bar	1
18	Handle	1
19	Caster	2
20	Bolt M8x60	4
21	Nut M8	12
22	Washer M16x2T	4
23	Spacer	2
24	Cotter Pin	2
25	Bolt M12x100	2
26	Nut M12	2
27	Bolt M8x50	2
28	Bolt M8x45	2
29	Bolt M8x40	2

Record Serial Number Here:

Note: If product has no serial number, record month and year of purchase instead.

Note: Some parts are listed and shown for illustration purposes only, and are not available individually as replacement parts.

Assembly Diagram

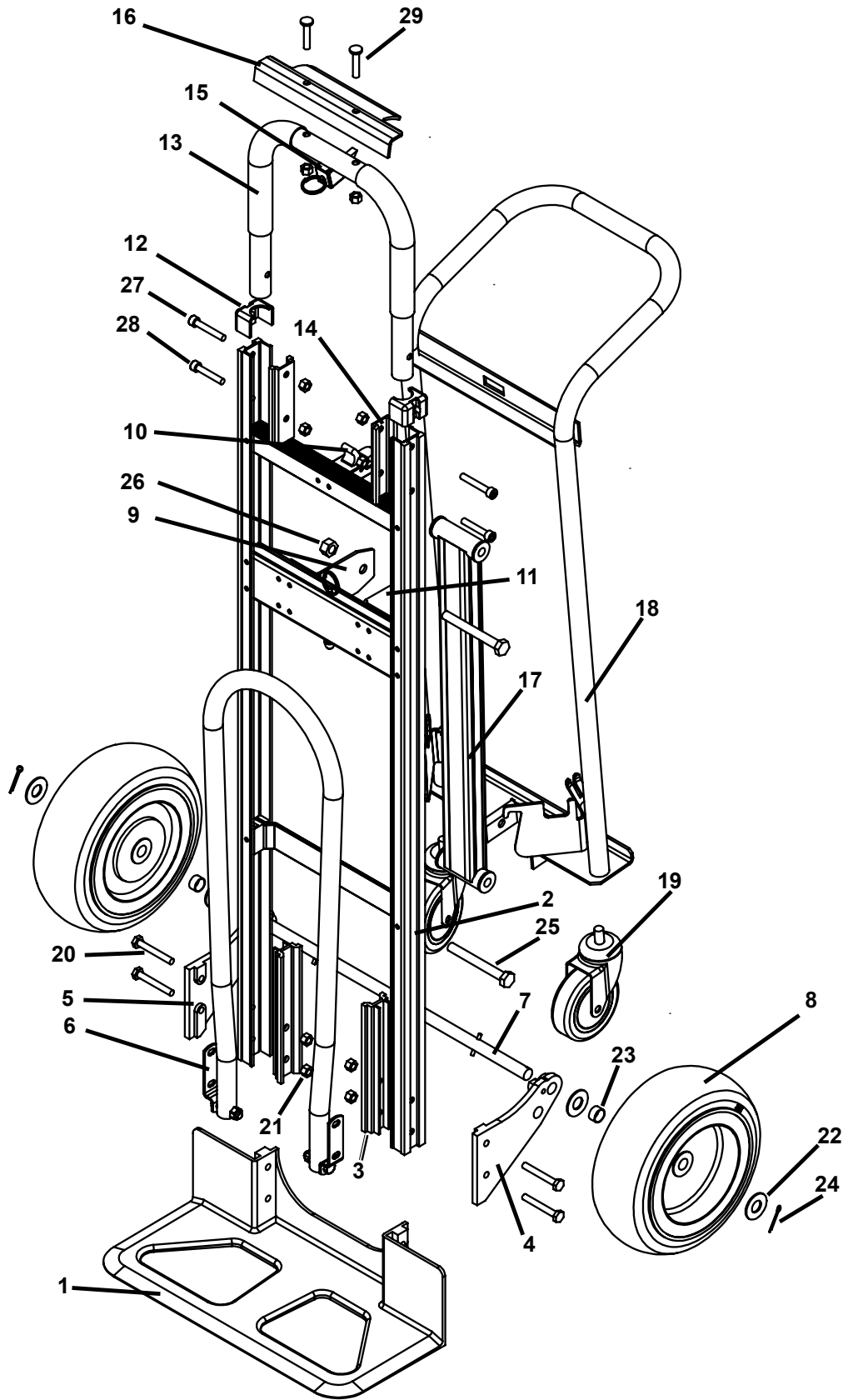

Limited 90 Day Warranty

Harbor Freight Tools Co. makes every effort to assure that its products meet high quality and durability standards, and warrants to the original purchaser that this product is free from defects in materials and workmanship for the period of 90 days from the date of purchase. This warranty does not apply to damage due directly or indirectly, to misuse, abuse, negligence or accidents, repairs or alterations outside our facilities, criminal activity, improper installation, normal wear and tear, or to lack of maintenance. We shall in no event be liable for death, injuries to persons or property, or for incidental, contingent, special or consequential damages arising from the use of our product. Some states do not allow the exclusion or limitation of incidental or consequential damages, so the above limitation of exclusion may not apply to you. THIS WARRANTY IS EXPRESSLY IN LIEU OF ALL OTHER WARRANTIES, EXPRESS OR IMPLIED, INCLUDING THE WARRANTIES OF MERCHANTABILITY AND FITNESS.

To take advantage of this warranty, the product or part must be returned to us with transportation charges prepaid. Proof of purchase date and an explanation of the complaint must accompany the merchandise. If our inspection verifies the defect, we will either repair or replace the product at our election or we may elect to refund the purchase price if we cannot readily and quickly provide you with a replacement. We will return repaired products at our expense, but if we determine there is no defect, or that the defect resulted from causes not within the scope of our warranty, then you must bear the cost of returning the product.

This warranty gives you specific legal rights and you may also have other rights which vary from state to state.



26541 Agoura Road • Calabasas, CA 91302 • 1-888-866-5797