

Owner's Manual & Safety Instructions

Save This Manual Keep this manual for the safety warnings and precautions, assembly, operating, inspection, maintenance and cleaning procedures. Write the product's serial number in the back of the manual near the assembly diagram (or month and year of purchase if product has no number). Keep this manual and the receipt in a safe and dry place for future reference.

23e

U.S. GENERAL

56" DOUBLE BANK ROLLER CABINET



70341 58714 70344 70345

Visit our website at: <http://www.harborfreight.com>
Email our technical support at: productsupport@harborfreight.com

When unpacking, make sure that the product is intact and undamaged. If any parts are missing or broken, please call 1-888-866-5797 as soon as possible.

Copyright© 2023 by Harbor Freight Tools®. All rights reserved.

No portion of this manual or any artwork contained herein may be reproduced in any shape or form without the express written consent of Harbor Freight Tools. Diagrams within this manual may not be drawn proportionally. Due to continuing improvements, actual product may differ slightly from the product described herein. Tools required for assembly and service may not be included.

⚠ WARNING

Read this material before using this product. Failure to do so can result in serious injury. **SAVE THIS MANUAL.**

Specifications

Electrical Rating	Input: 15A, 100-125V, 60Hz, 1875W Max
	AC Output: 15A, 100-125V, 60Hz, 1875W Max USB Output: 5VDC 3A/9VDC 2.22A/ 12VDC 1.67A Type-C Output: 5VDC 3A/9VDC 2.22A/ 12VDC 1.67A Total USB Output: 20W (max)
Total Combined Weight Capacity (Evenly distributed from bottom up.)	4400 lb.
Drawer Capacity (per connected pair of slides)	120 lb.

IMPORTANT SAFETY INSTRUCTIONS

READ AND FOLLOW ALL INSTRUCTIONS

Assembly Precautions

1. Assemble only according to these instructions. Improper assembly can create hazards.
2. Wear ANSI-approved safety goggles and heavy-duty work gloves during assembly.
3. Keep assembly area clean and well lit.
4. Keep bystanders out of the area during assembly.
5. Do not assemble when tired or when under the influence of alcohol, drugs or medication.
6. Weight capacity and other product capabilities apply to properly and completely assembled product only.
7. Assemble on a flat, level, hard and smooth surface capable of safely supporting a fully loaded Cabinet.

Use Precautions

1. **To prevent serious injury and death from tipping, Do not have more than one drawer open at a time.**
2. **DO NOT SIT, STAND OR CLIMB ON THIS ITEM. DO NOT STEP IN OR ON DRAWERS.**
3. **Unplug roller cabinet before drilling mounting holes to mount workcenter hutch.**
4. This product is not a toy nor a toy chest. Do not allow children to play with or near this item.
5. Do not exceed weight capacities, evenly distributed from bottom up.
Be aware of dynamic loading!
Sudden load movement may briefly create excess load causing product failure.
6. Do not open more than one Drawer at once.
7. Empty, close, and lock Drawers before moving.
8. Use only on a flat, level, hard and smooth surface capable of safely supporting a fully loaded Cabinet. Do not roll Cabinet over concrete seams or other rough/uneven surfaces.
9. Do not lift using handle(s). Do not move or lift while loaded.
10. Lock Swivel Casters after moving.
11. Do not mount on truck bed or any other moving object.
12. Do not operate equipment with a damaged cord.
13. Do not let a cord hang over the edge of the table, bench, or counter or come in contact with hot manifolds or moving fan blades.
14. If an extension cord is necessary, a cord with a current rating equal to or more than that of the equipment should be used. Cords rated for less current than the equipment may overheat. Care should be taken to arrange the cord so that it will not be tripped over or pulled.
15. Always unplug equipment from electrical outlet when not in use. Never use the cord to pull the plug from the outlet. Grasp plug and pull to disconnect.
16. Loop cord loosely around equipment when storing.

17. To reduce the risk of electric shock or fire, never overload receptacles. Refer to markings for the proper load on receptacles.
18. To reduce the risk of electric shock, do not use on wet surfaces or expose to rain.
19. To reduce the risk of fire, do not use the power strip in the vicinity of open containers of flammable liquids (gasoline).
20. Do not use the equipment with a damaged cord or if the equipment has been dropped or damaged – until it has been examined by a qualified service person.
21. Use as intended only.
22. Inspect before every use; do not use if parts are loose or damaged.
23. Maintain product labels and nameplates. These carry important safety information. If unreadable or missing, contact Harbor Freight Tools for a replacement.
24. People with pacemakers should consult their physician(s) before use. Electromagnetic fields in close proximity to heart pacemaker could cause pacemaker interference or pacemaker failure. In addition, people with pacemakers should:
 - Avoid operating alone.
 - Properly maintain and inspect to avoid electrical shock.
 - Properly ground power cord.Ground Fault Circuit Interrupter (GFCI) should also be implemented – it prevents sustained electrical shock.
25. Keep hair, loose clothing, fingers, and all parts of body away from moving parts.
26. Use only as described in this manual. Use only manufacturer's recommended attachments.
27. ALWAYS WEAR SAFETY GLASSES. Everyday eyeglasses only have impact resistant lenses, they are not safety glasses.
28. To reduce the risk of injury, close supervision is necessary when this product will be used around children.
29. To reduce the risk of injury, never overload the drawers or shelves. Refer to loading instructions.



SAVE THESE INSTRUCTIONS.

U.S. GENERAL

Assembly Instructions



Read the **ENTIRE IMPORTANT SAFETY INFORMATION** section at the beginning of this document including all text under subheadings therein before set up or use of this product.

1. Assemble on a flat, level, hard and smooth surface capable of safely supporting a fully loaded unit.
2. Attach Side Handles (6) using Handle Screws (7).

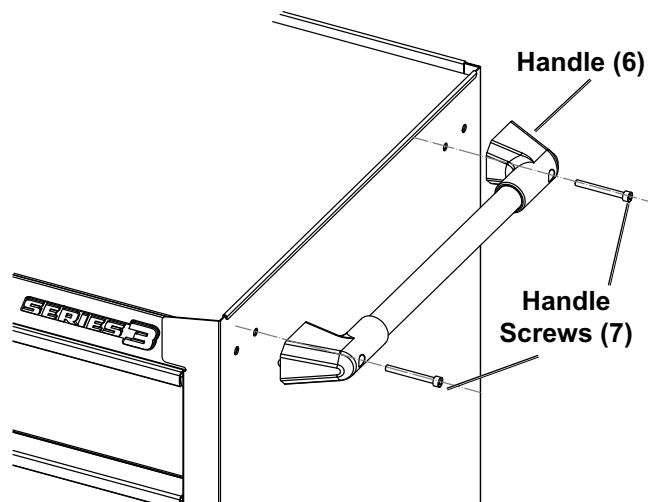

Connecting Cabinets

1. Unplug Cabinets from outlet.
2. Empty all Drawers from Cabinets.
3. Remove all attachments from Cabinets.
4. Assemble on solid flat surface.
5. Remove Top Drawers from Cabinets.
6. Remove two Handle Screws (7) from Handle (6) from Cabinet A.
7. Remove Handle.

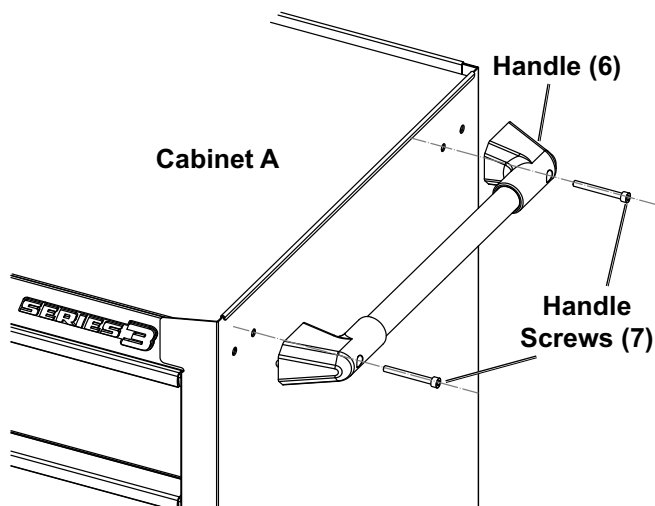

8. Rotate both Swivel Casters (22) sideways on Cabinet A to keep Casters from hitting each other.

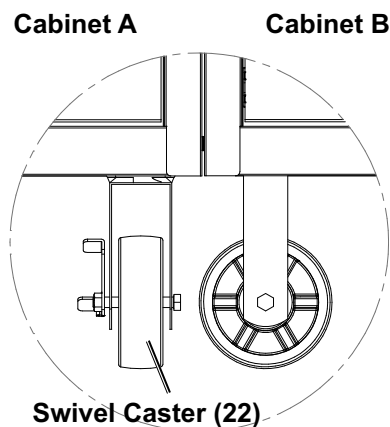

9. Place Cabinet A and Cabinet B together, Ensure Cabinets are pressed firmly together, refer to Figure A.

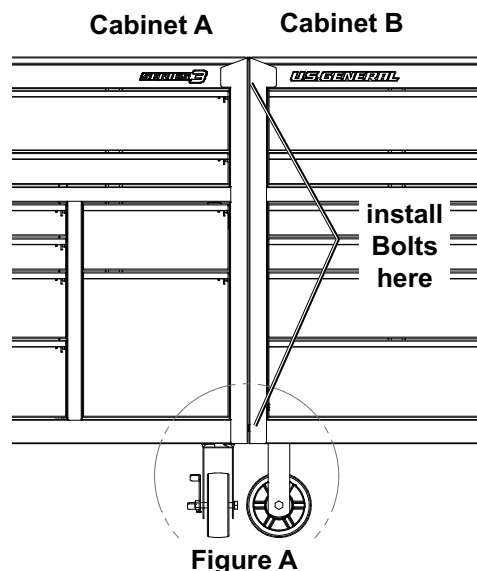

10. Place two M6x25 Bolts (25) through upper outer holes from one Cabinet to the other Cabinet. Secure Bolts with M6 Nuts (26) and tighten.

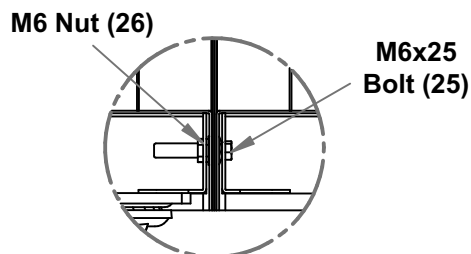
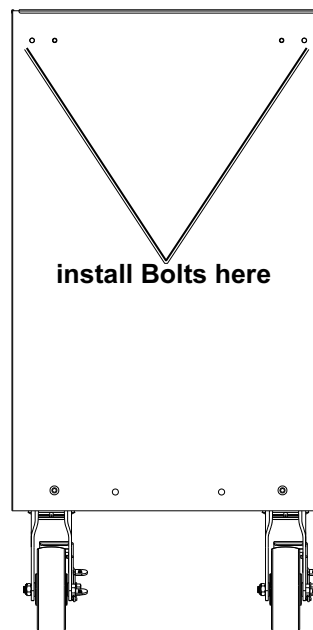

11. Place two M8x35 Bolts (27) through holes underneath Cabinets from one Cabinet to the other Cabinet. Secure Bolts with M8 Nuts (28) and tighten.

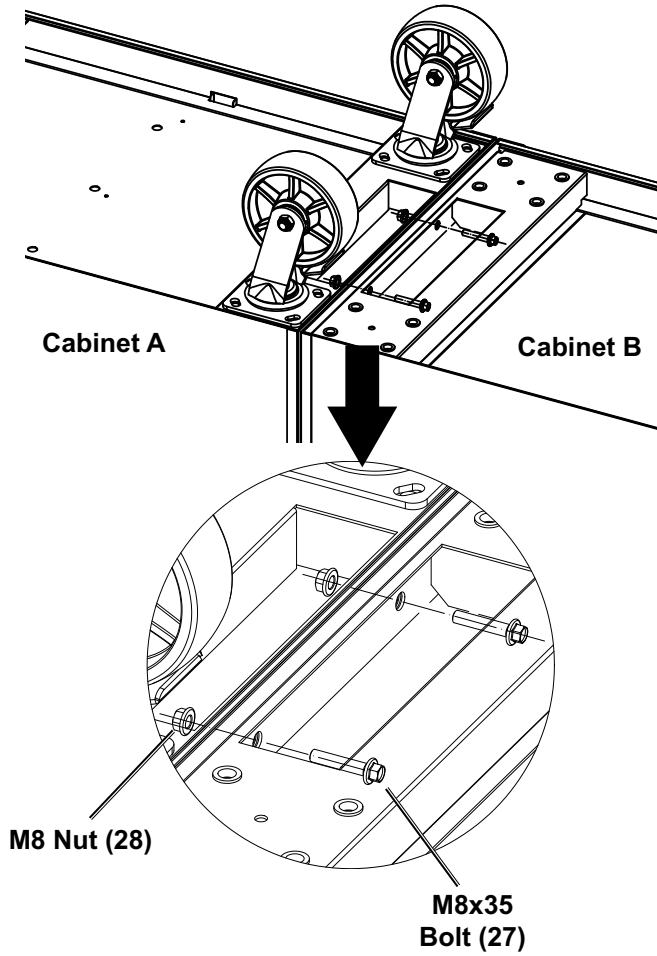

12. With Cabinets connected, remove eight Bolts (8) from two Fixed Casters (23) on Cabinet B.

13. Remove two Fixed Casters from Cabinet B.

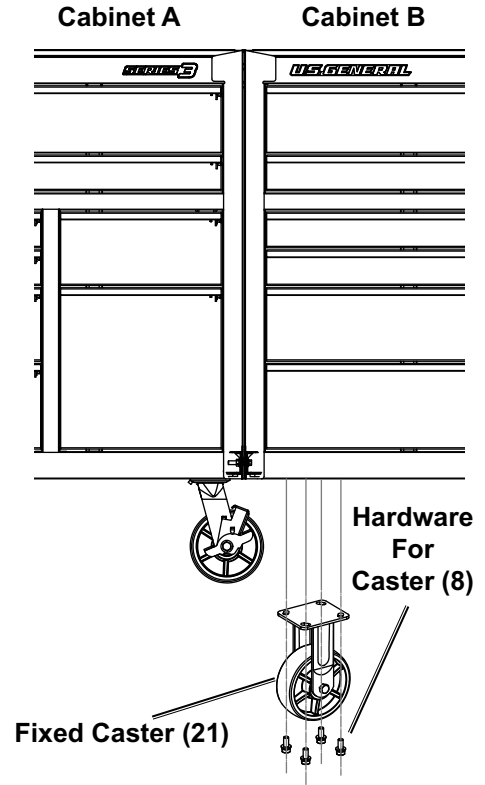

14. Install two Top Drawers into Cabinets.

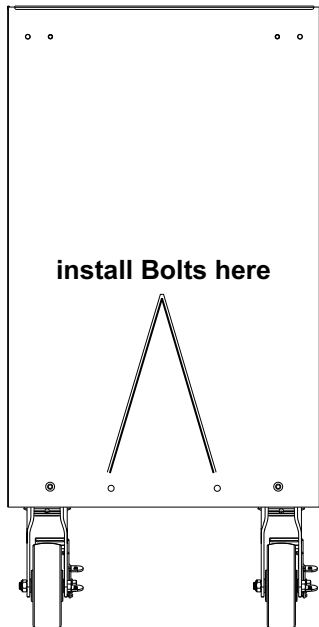

Operation Instructions



Read the **ENTIRE IMPORTANT SAFETY INFORMATION** section at the beginning of this document including all text under subheadings therein before set up or use of this product.

1. Empty all Drawers.
2. Close all Drawers and lock them.
3. Unlock Swivel Casters.
4. Move using supplied handle on Bottom Cabinet only to prevent tipping. Roll Cabinet to a flat, level, hard and smooth surface capable of safely supporting a fully loaded Cabinet. Do not roll Cabinet over concrete seams or other rough/uneven surfaces.
5. Lock Swivel Casters.

Note: All Drawers have safety latches under right ends of Drawer Handles.

6. Connect SJTOW Power Cord to a properly grounded, GFCI-protected 120VAC outlet. Keep Power Cord off the ground to prevent damage.

WARNING! To prevent serious injury from electric shock and fire, ensure all cords are positioned where they will not be pinched or cut by Drawer or Caster movement. Keep Power Cord off the ground to prevent damage.

7. Plug devices into the Power Strip inside Drawer on the right-hand side. Turn switch on.

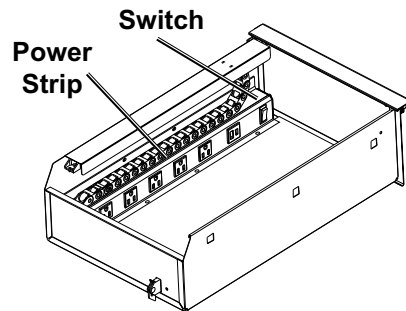

8. Unlock Drawers, and fill Cabinet evenly, from bottom to top. Do not exceed weight capacities.
9. If the power to the outlets turns off, check the following:
 - a. Check that switch has not been bumped to the off position. Turn the switch off and on again.
 - b. Unplug Cabinet's power cord from the wall. Check that all device cords are undamaged and not pinched.
 - c. If circuit breaker keeps tripping, check that Power Strip's amp rating is not exceeded and all attached devices are working properly.

Maintenance and Servicing



Procedures not specifically explained in this manual must be performed only by a qualified technician.

!WARNING

TO PREVENT SERIOUS INJURY FROM TOOL FAILURE:

Do not use damaged equipment. If any part becomes damaged, have the problem corrected before further use.

1. **PERIODICALLY**, inspect the general condition of the Cabinet. Check for:
 - loose hardware,
 - misalignment or binding of moving parts,
 - brake operation,
 - caster swivel function and movement,
 - cracked or broken parts,
 - any other condition that may affect its safe operation.
2. Wipe external surfaces of the Cabinet with clean cloth.
3. Lubricate Drawer Slides as needed.

PLEASE READ THE FOLLOWING CAREFULLY

THE MANUFACTURER AND/OR DISTRIBUTOR HAS PROVIDED THE PARTS LIST AND ASSEMBLY DIAGRAM IN THIS DOCUMENT AS A REFERENCE TOOL ONLY. NEITHER THE MANUFACTURER OR DISTRIBUTOR MAKES ANY REPRESENTATION OR WARRANTY OF ANY KIND TO THE BUYER THAT HE OR SHE IS QUALIFIED TO MAKE ANY REPAIRS TO THE PRODUCT, OR THAT HE OR SHE IS QUALIFIED TO REPLACE ANY PARTS OF THE PRODUCT. IN FACT, THE MANUFACTURER AND/OR DISTRIBUTOR EXPRESSLY STATES THAT ALL REPAIRS AND PARTS REPLACEMENTS SHOULD BE UNDERTAKEN BY CERTIFIED AND LICENSED TECHNICIANS, AND NOT BY THE BUYER. THE BUYER ASSUMES ALL RISK AND LIABILITY ARISING OUT OF HIS OR HER REPAIRS TO THE ORIGINAL PRODUCT OR REPLACEMENT PARTS THERETO, OR ARISING OUT OF HIS OR HER INSTALLATION OF REPLACEMENT PARTS THERETO.

Record Serial Number Here: _____

Note: If product has no serial number, record month and year of purchase instead.

Note: Some parts are listed and shown for illustration purposes only, and are not available individually as replacement parts. Parts may not be interchangeable. Specify UPC number when ordering:

Black: - 193175510457 - 70341

Blue: - 193175510440 - 70344

Gray: - 193175510433 - 70345

Red: - 193175486332 - 58714

Parts List and Diagram

Parts List

Part	Description	Qty
1	Drawer Slide	12
2	Screw	24
3	Drawer Trim	2
4	Deep Drawer Liner	1
5	Drawer Locking Latch	2
6	Handle	1
7	Handle Screw	2
8	Hardware For Caster	16
9	Lock Bar	1
10	Lock Tab	1
11	Lock	1
12	Key (not shown)	4
13	Drawer Trim	4
14	Moderate-Width Drawer Liner	4
15	Drawer Locking Latch	4
16	Drawer Trim	2
17	Wide Drawer Liner	2
18	Drawer Locking Latch	2

Part	Description	Qty
19	Power Drawer Liner	1
20	Power Strip	1
21	Fixed Caster	2
22	Swivel Caster With Brake	2
23	Top Rubber Mat	1
24	Power Cord (not shown)	1
25	M6x25 Bolt	2
26	M6 Nut	2
27	M8x35 Bolt	2
28	M8 Nut	2
A	Drawer	2
B	Drawer	1
C	Drawer	1
D	Drawer	1
E	Drawer	1
F	Drawer	1
G	Drawer	1

Assembly Diagram

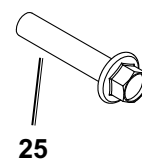
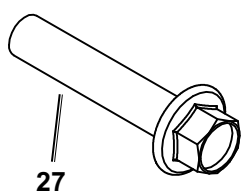
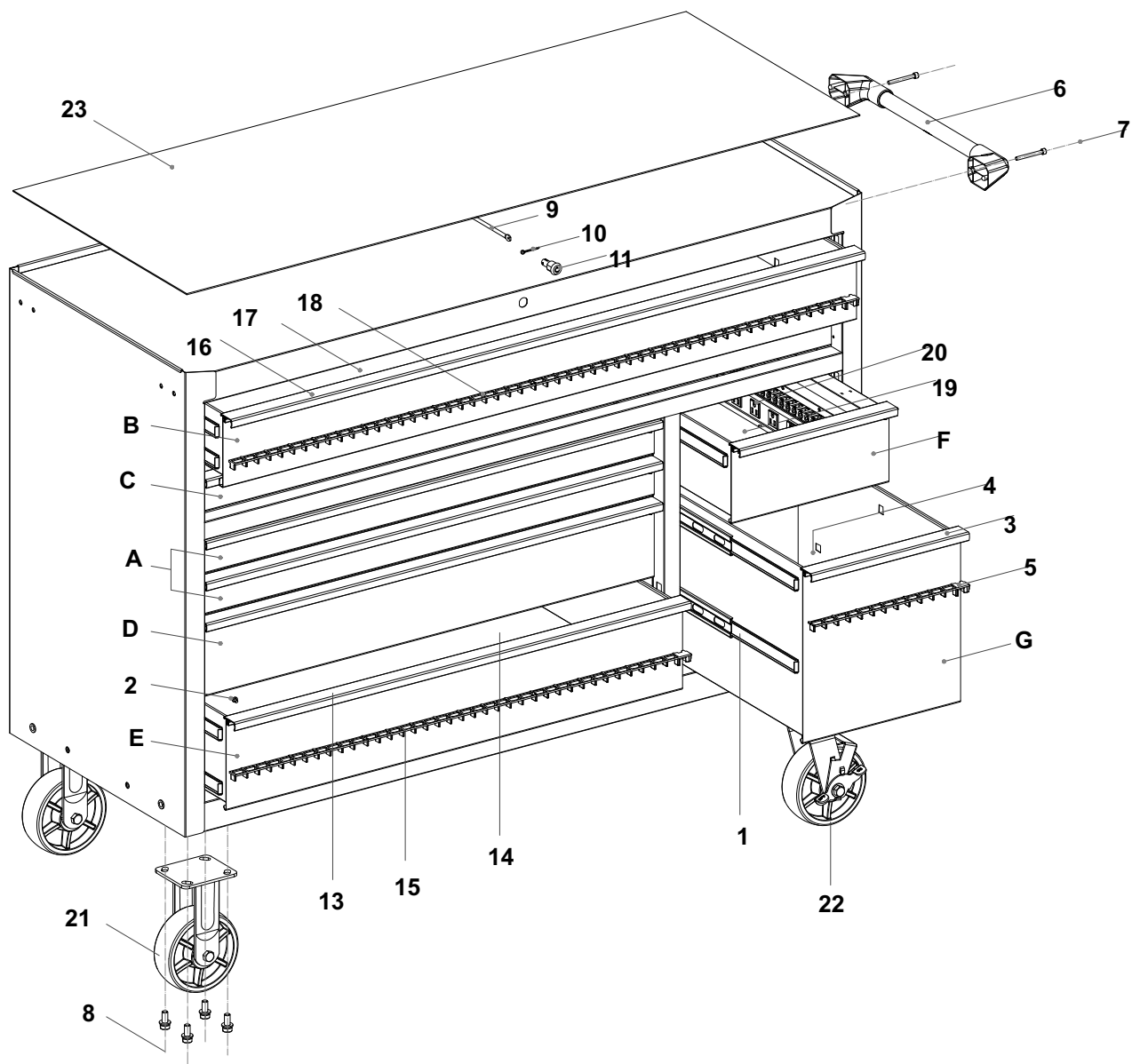

Limited 90 Day Warranty

Harbor Freight Tools Co. makes every effort to assure that its products meet high quality and durability standards, and warrants to the original purchaser that this product is free from defects in materials and workmanship for the period of 90 days from the date of purchase. This warranty does not apply to damage due directly or indirectly, to misuse, abuse, negligence or accidents, repairs or alterations outside our facilities, criminal activity, improper installation, normal wear and tear, or to lack of maintenance. We shall in no event be liable for death, injuries to persons or property, or for incidental, contingent, special or consequential damages arising from the use of our product. Some states do not allow the exclusion or limitation of incidental or consequential damages, so the above limitation of exclusion may not apply to you. THIS WARRANTY IS EXPRESSLY IN LIEU OF ALL OTHER WARRANTIES, EXPRESS OR IMPLIED, INCLUDING THE WARRANTIES OF MERCHANTABILITY AND FITNESS.

To take advantage of this warranty, the product or part must be returned to us with transportation charges prepaid. Proof of purchase date and an explanation of the complaint must accompany the merchandise. If our inspection verifies the defect, we will either repair or replace the product at our election or we may elect to refund the purchase price if we cannot readily and quickly provide you with a replacement. We will return repaired products at our expense, but if we determine there is no defect, or that the defect resulted from causes not within the scope of our warranty, then you must bear the cost of returning the product.

This warranty gives you specific legal rights and you may also have other rights which vary from state to state.

U.S. GENERAL

26677 Agoura Road • Calabasas, CA 91302 • 1-888-866-5797