

# Owner's Manual & Safety Instructions

**Save This Manual** Keep this manual for the safety warnings and precautions, assembly, operating, inspection, maintenance and cleaning procedures. Write the product's serial number in the back of the manual near the assembly diagram (or month and year of purchase if product has no number). Keep this manual and the receipt in a safe and dry place for future reference.

22j

# CENTRAL<sup>®</sup> MACHINERY

## 20 TON SHOP PRESS

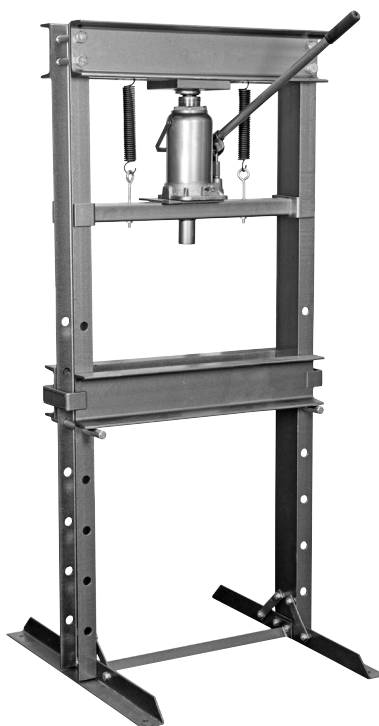

Visit our website at: <http://www.harborfreight.com>  
Email our technical support at: [productsupport@harborfreight.com](mailto:productsupport@harborfreight.com)

70603

When unpacking, make sure that the product is intact and undamaged. If any parts are missing or broken, please call 1-888-866-5797 as soon as possible.

Copyright© 2022 by Harbor Freight Tools®. All rights reserved.  
No portion of this manual or any artwork contained herein may be reproduced in any shape or form without the express written consent of Harbor Freight Tools. Diagrams within this manual may not be drawn proportionally. Due to continuing improvements, actual product may differ slightly from the product described herein.  
Tools required for assembly and service may not be included.

### **⚠ WARNING**

**Read this material before using this product.  
Failure to do so can result in serious injury.  
SAVE THIS MANUAL.**

# Table of Contents





Safety .....	2	Operation .....	8
Specifications .....	4	Maintenance .....	9
Setup .....	4	Warranty .....	12

SAFETY

SETUP

OPERATION

MAINTENANCE

WARNING SYMBOLS AND DEFINITIONS	
	This is the safety alert symbol. It is used to alert you to potential personal injury hazards. Obey all safety messages that follow this symbol to avoid possible injury or death.
	Indicates a hazardous situation which, if not avoided, will result in death or serious injury.
	Indicates a hazardous situation which, if not avoided, could result in death or serious injury.
	Indicates a hazardous situation which, if not avoided, could result in minor or moderate injury.
	Addresses practices not related to personal injury.

## IMPORTANT SAFETY INFORMATION

### Shop Press Overall Safety Warnings

1. Study, understand, and follow all instructions before operating the device.
2. Do not exceed rated capacity.
3. Keep hands, arms, feet and legs out of the work area.
4. Wear eye protection.
5. Avoid off-center loads.
6. Failure to heed and understand these instructions and warnings may result in personal injury and/or property damage.
7. The press shall be installed and operated in accordance with federal (OSHA), state, and local safety standards.
8. Use appropriate guarding to contain any pieces that may break or fly apart when applying force.
9. When attachments and adapters are used, the rated capacity of the system shall be no greater than the rated capacity of the lowest-rated component or combination of components that make up the system.
10. Operators and observers shall wear eye protection that meets ANSI/ISEA Z887.1 and OSHA standards.
11. Prior to use, make sure the press is securely anchored.
12. Verify lift cables are slack before pressing on the bolster.
13. No alterations shall be made to this product.
14. Do not operate if workpiece tilts or binds during compression.
15. Keep hands away from arbor plates and press pin during use.
16. Do not move workpiece while compressed.
17. Release load before service or maintenance.
18. Keep area under arbor plates clear. If arbor plates rest on obstruction (i.e. bolt, debris, etc.), it creates an uneven press, causing excess stress and possible breakage.
19. STOP and release compression if you suspect imminent structural failure. If safe, inspect thoroughly and reposition before proceeding.
20. Do not compress springs or other elastic objects. They could disengage hazardously.

21. Wear ANSI-approved safety goggles, heavy-duty work gloves, and steel-toe work boots during set up and/or use.
22. Keep bystanders out of work area.
23. Do not stand directly in front of the press when loaded. Do not leave the press unattended when loaded.
24. Inspect before every use; do not use if parts are loose or damaged.
25. Only use with accessories rated to handle the forces exerted by this tool during operation. Other accessories not designed for the forces generated may break and forcefully launch pieces.
26. This product is not a toy. Keep it out of reach of children.
27. Maintain labels and nameplates on the Shop Press. These carry important safety information. If unreadable or missing, contact Harbor Freight Tools for a replacement.
28. The warnings, precautions, and instructions discussed in this instruction manual cannot cover all possible conditions and situations that may occur. It must be understood by the operator that common sense and caution are factors which cannot be built into this product, but must be supplied by the operator.

## Safety Warnings for Included Bottle Jack

---

1. Do not use as lifting device. Attach securely to shop press before use.
2. Do not remove, unless for replacement.
3. Do not exceed 20 ton rated capacity.
4. Do not adjust safety valve.
5. Jack service must be performed only by qualified repair personnel. Service or maintenance performed by unqualified personnel could result in a risk of injury.
6. When servicing a jack, use only identical replacement parts – refer to attached, product-specific parts list and diagram. Follow instructions in the “User - Maintenance Instructions” section of this manual. Use of unauthorized parts or failure to follow maintenance instructions may create a risk of injury.

## Bottle Jack Replacement Safety Warnings

---

1. Rating of replacement Bottle Jack needs to match exactly.
2. Bottle Jack must fit securely into place on both the upper beam and the Jack Plate before use.
3. Position replacement Bottle Jack carefully on center of Jack Plate.
4. Replace Bottle Jack only with exact replacement part or Pittsburgh standard bottle jack. Do not replace with an air/hydraulic bottle jack nor a low-profile bottle jack.



**SAVE THESE INSTRUCTIONS.**

## Specifications

Maximum Capacity	20 Tons (40,000 pounds)
Oil Type	Hydraulic Oil

**Note:** For additional information regarding the parts listed in the following pages, refer to the *Parts List and Assembly Diagram* near the end of this manual.

## Setup - Before Use:



Read the **ENTIRE IMPORTANT SAFETY INFORMATION** section at the beginning of this manual including all text under subheadings therein before set up or use of this product.

## WARNING

Inspect tool before use, looking for damaged, loose, and missing parts. If any problems are found, do not use tool until repaired.

Components of this Shop Press are heavy. You will need a helper to safely assemble this product.

Note: For additional information regarding the parts listed in the following pages, refer to the Assembly Diagram near the end of this manual.

## Assembly

- Using the Components photo on page 9 and the Parts List and Assembly Diagram near the end of the manual, lay out and identify all pieces before assembly.
- Slide each Base Section (21) under the Frame Posts (16), and place the Bottom Frame Support (22) between them. Line up the bolt holes and insert the Bolts (14) through the Frame Posts, Base Sections, and Bottom Frame Support, then secure in place with the Washers (12) and Nuts (13).
- Attach the Base Section Supports (20) to the Frame Posts and Base Sections using the Bolts (11), Washers (12), and Nuts (13). See Figure 2.
- Determine where the Shop Press will be located. Check to ensure that the Frame Posts are perpendicular to the Base Supports, then bolt to the floor. Refer to *Mounting to the Floor* on page 6.
- Slide the Support Pins (10) into the holes in the Frame Posts (16). With assistance, lift the Press Apron (19) to the top of the Frame Posts, then lower into place down the Frame Posts so the Press Apron rests on the Support Pins. See Figure 3.

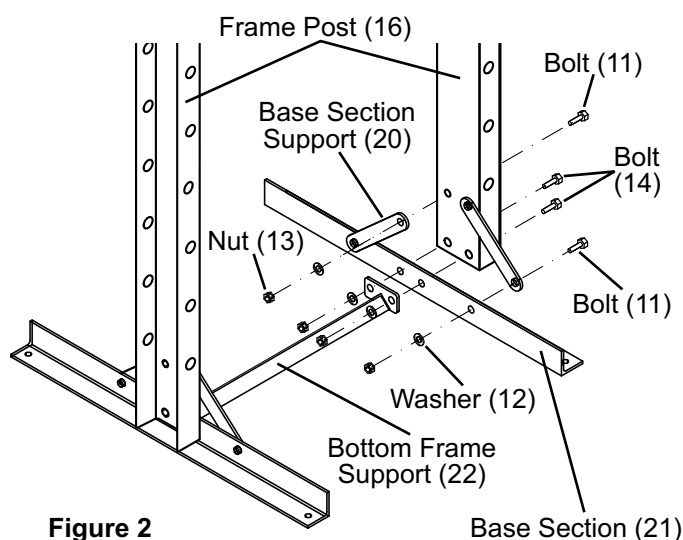

Figure 2

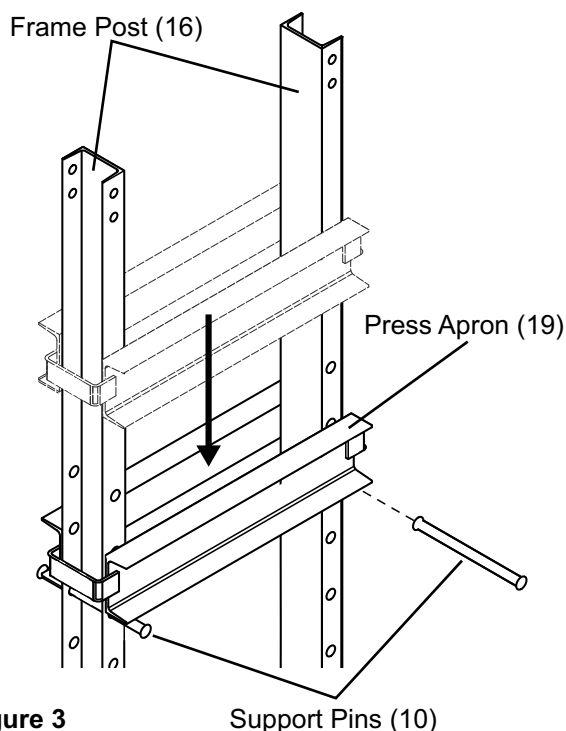

Figure 3

- Attach the Base Section Supports (20) to the Frame Posts and Base Sections using the Bolts (11), Washers (12), and Nuts (13). See Figure 2.
- Determine where the Shop Press will be located. Check to ensure that the Frame Posts are perpendicular to the Base Supports, then bolt to the floor. Refer to *Mounting to the Floor* on page 6.

**Note:** For set-up, position the Support Pins at least several holes down from the top holes in the Frame Posts so you have room to place the Jack Plate (17). You can re-adjust the placement of the Press Apron after assembly.

6. **Align** the holes on the Upper Beam (15) with the holes in the top of the Frame Posts (16) and secure in place with the Bolts (1), Washers (2), Spring Washers (3), and Nuts (4). Align the Upper Beam with the bottle jack bracket on the bottom. Check that the assembly is square, then finish tightening bolts. See Figure 4.

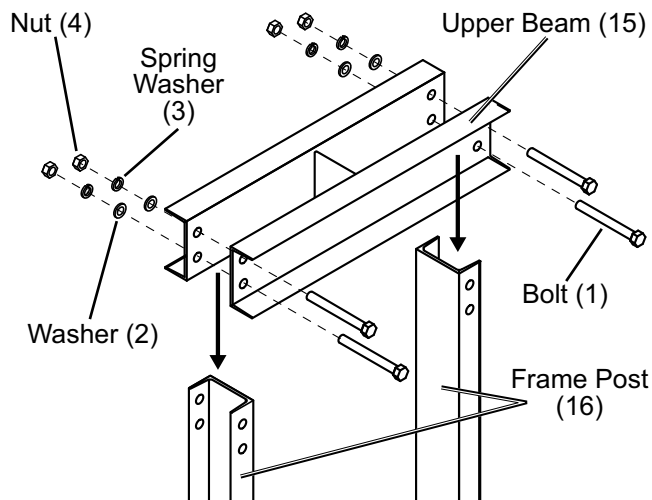

Figure 4

7. Insert two Eye Bolts (8) into the holes in the Jack Plate (17) and secure in place with the Nuts (9).

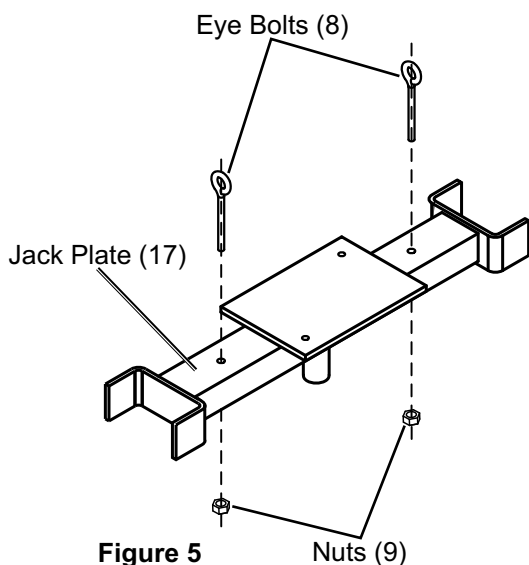

Figure 5

8. Angle the Jack Plate (17) so the rails of the Jack Plate straddle the Frame Posts (16), then lower into place by sliding it down the Frame Posts so it rests temporarily on the Press Apron. See Figure 6.

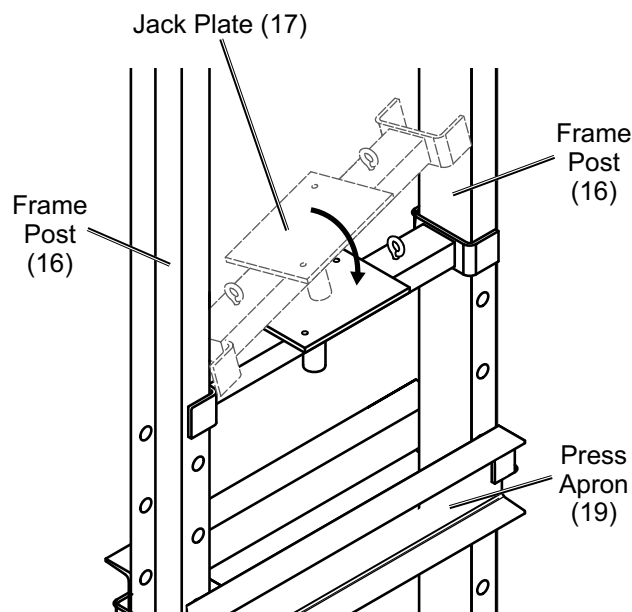

Figure 6

9. Bleed the Bottle Jack (6) (see *Bleeding the Bottle Jack* section) and make sure it is fully collapsed.

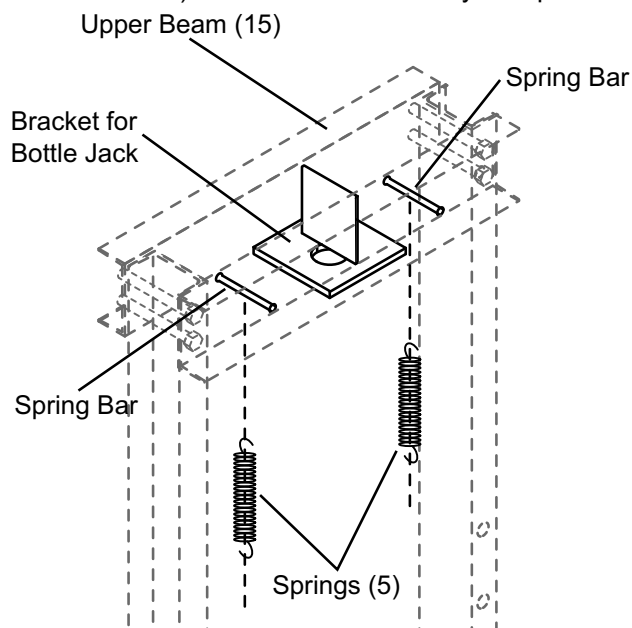
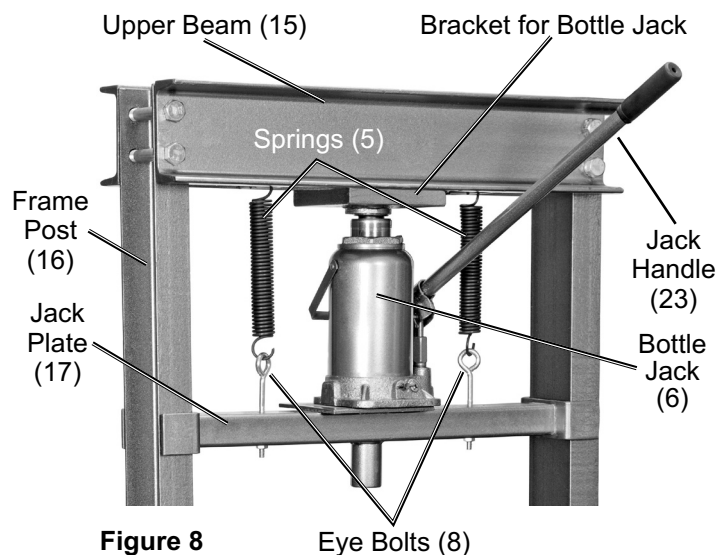

Figure 7

## Hang the Bottle Jack

1. Hang the Springs (5) on the bars of the Upper Beam. See Figure 8.
1. Place the Bottle Jack on the center of the Jack Plate (17), align it with two mounting holes in the Jack Plate and secure with two Bolts (7).
2. Slide the Jack Plate up the Frame Posts (16) so the Bottle Jack Saddle fits in the bracket on the center underside of the Upper Beam.
3. Hook the Springs into the Eye Bolts (8) on the Jack Plate to secure the Bottle Jack/ Jack Plate in place. See Figure 8.



## Mounting to the Floor

1. With assistance, move the Shop Press to the location where it is to be mounted. If needed, drill four 1/2" diameter mounting holes in the Base Supports and use as a template to mark the spots where four 1/2" diameter holes will be drilled in the concrete or wood floor. Check for any hidden wiring or cables and adjust the location for the holes as needed. Then, temporarily set the Shop Press aside.
2. For concrete floors use a masonry drill bit to drill the four 1/2" diameter holes (about 3"-4" deep) into the concrete. Make sure to blow out the concrete dust from the drilled holes. Insert lag screw anchors (not included) into the holes.
3. Move the Shop Press back to the location where it is to be mounted, and align the four 1/2" diameter mounting holes in the Base Supports with the four pre-drilled 1/2" holes in the concrete or wood. Use four minimum 3" long, 1/2" diameter concrete anchor bolts or lag bolts (not included) to secure the Shop Press to the concrete or wood floor.

# Components and Controls

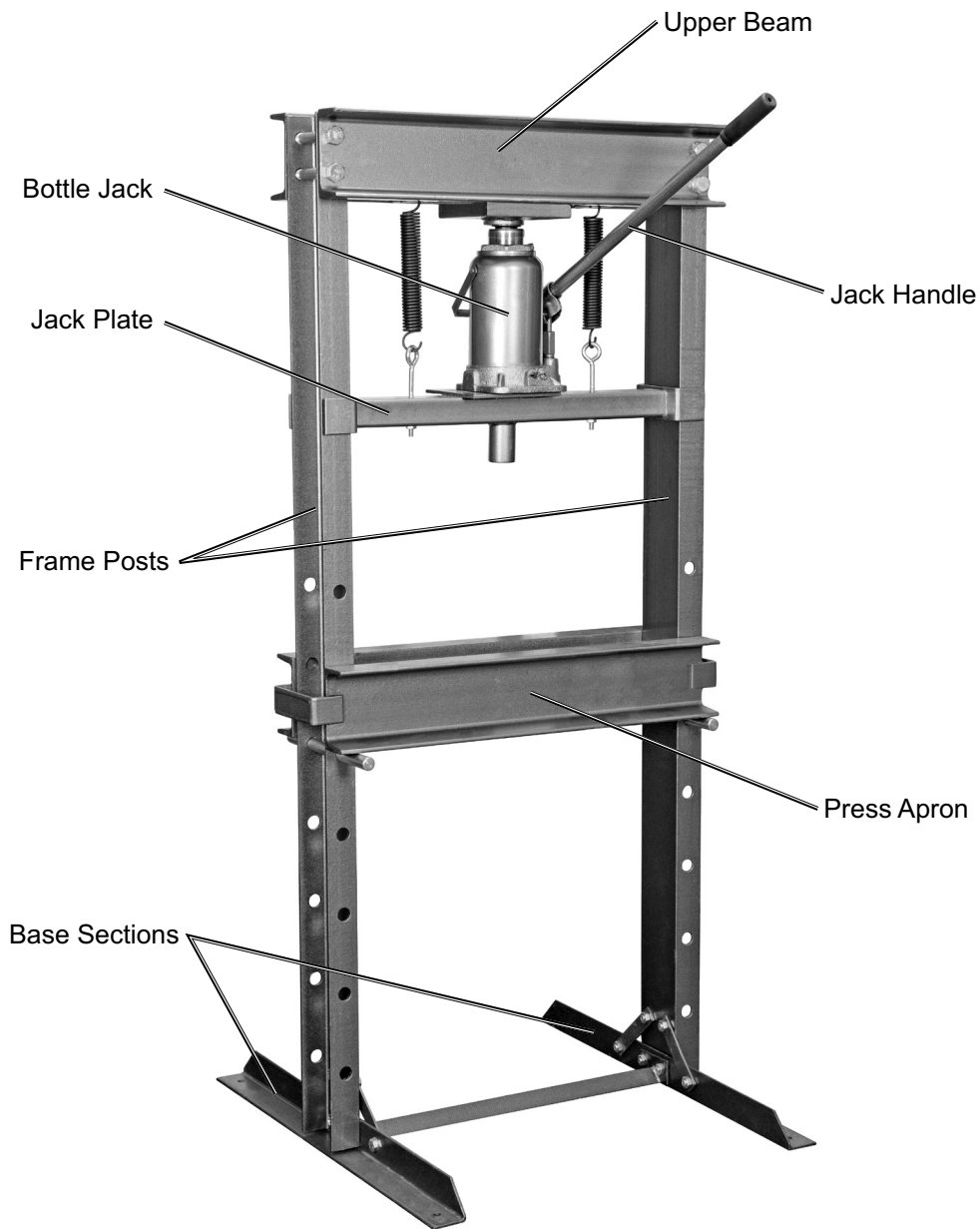

SAFETY

SETUP

OPERATION

MAINTENANCE

## Operating Instructions



Read the **ENTIRE IMPORTANT SAFETY INFORMATION** section at the beginning of this manual including all text under subheadings therein before set up or use of this product.

### Bleeding the Bottle Jack

**IMPORTANT!** Before first use, check for proper hydraulic oil level in the Jack. Then thoroughly test the Jack for proper operation prior to its actual use. If the Jack appears *not* to be working properly, it may be necessary to *bleed* its hydraulic system of excess air. To bleed the Bottle Jack:

1. Remove the Oil Filler Plug. Insert the slot on the lower portion of the Jack Handle over the Valve Release Screw. Turn the Handle counterclockwise to open the Valve Release Screw.
2. Insert the Handle into the Plunger/Fulcrum Assembly. Apply pressure to the Saddle, and pump the Handle quickly several times.
3. Check the Oil Fill Hole and, if necessary, top off the Oil Fill Hole with hydraulic oil.
4. Replace the Oil Filler Plug.
5. Place the slot on the Jack Handle over the Release Valve Screw. Turn the Handle clockwise to close the Release Valve.
6. Test the Jack several times before putting into use. If, after purging, the Jack still does not appear to be working properly, do not use the Jack until it has been repaired by a qualified service technician.

### Tool Set Up

1. Use the Support Pins (10) to adjust the height of the Press Apron (19).
2. The Press Apron should be in the highest position possible with the workpiece as close as possible to the ram of the Jack Plate (17).

**WARNING:** Keep area under Arbor Plates clear of stray bolts or debris. Such items create an uneven surface which can cause the Arbor Plates to break under pressure.

### Workpiece Set Up

**WARNING:** When pressing two items together, the items must be lined up vertically. If not, one item may forcefully eject sideways from the unit.

### General Operating Instructions

1. Place the item to press on the Arbor Plates (18). Turn the Arbor Plates to support the stationary part of the workpiece.
2. Using the Jack Handle (23), jack down the Jack Plate until the ram of the Jack Plate contacts the workpiece. When pressing two items together, make sure that they are in vertical alignment. Continue to operate the Jack Handle to press the work piece.
3. After the task is completed, be careful when releasing Jack pressure. For safety, remove the Jack Handle, then use the Handle to slowly turn the Valve Release Screw on the Jack, allowing the Jack Plate to rise.
4. Clean, then store the tool indoors out of children's reach.

**WARNING! TO PREVENT SERIOUS INJURY:** During the release process the Jack may rise quickly. Stay clear.





Procedures not specifically explained in this manual must be performed only by a qualified technician.

### **WARNING**

#### **TO PREVENT SERIOUS INJURY FROM TOOL FAILURE:**

Do not use damaged equipment. If abnormal noise or vibration occurs, have the problem corrected before further use.

## Cleaning, Maintenance, and Lubrication

1. **BEFORE EACH USE**, inspect the general condition of the Shop Press and Bottle Jack. Check for:
  - loose hardware
  - cracked, bent or broken parts
  - loose or missing parts
  - misalignment or binding of moving parts
  - any other condition that may affect its safe operation.
2. **BEFORE EACH USE**, test the Jack for proper operation. If the Bottle Jack appears not to be working properly, follow instructions in *Bleeding the Bottle Jack* on page .
3. **AFTER USE**, wipe external surfaces of the tool with clean cloth.

## Hydraulic Oil

Change the hydraulic oil at least once every three years. To change the hydraulic oil:

1. With the Jack fully lowered, unhook the Springs (5) from the Eye Bolts (8), remove two bolts (7), and remove the Jack from the Jack Plate (17).
2. Remove the Oil Filler Plug.
3. Tip the Bottle Jack to allow the old hydraulic oil to drain out of the unit completely, and dispose of the old hydraulic oil in accordance with local regulations.
4. Completely fill the unit with a high quality hydraulic oil (not included) until the oil just begins to run out of the Oil Fill Hole.
5. Reinstall the Oil Filler Plug.
6. Clean with a clean cloth using a detergent or mild solvent.
7. Replace the Bottle Jack onto the Shop Press. Refer to Hang the Bottle Jack on page 6.

# Troubleshooting

## ⚠️ WARNING

**TO PREVENT SERIOUS INJURY:**

Use caution when troubleshooting a malfunctioning jack.

Completely resolve all problems before use. If the solutions presented in the

Troubleshooting guide do not solve the problem, have a qualified technician inspect and repair the jack before use.

**After the jack is repaired: Test it carefully without a load by raising it and lowering it fully, checking for proper operation, BEFORE RETURNING THE JACK TO OPERATION.**

## DO NOT USE A DAMAGED OR MALFUNCTIONING JACK!

POSSIBLE SYMPTOMS						PROBABLE SOLUTION (Make certain that the jack is not supporting a load while attempting a solution.)
Jack will not function at its weight capacity	Saddle lowers under load	Pump stroke feels spongy	Saddle will not lift all the way	Handle moves up when jack is under load	Oil leaking from filler plug	
X	X					Check that Release Valve is closed fully.
X	X			X		Valves may be blocked and may not close fully. To flush the valves: 1. Lower the Saddle and securely close the Release Valve. 2. Manually lift the saddle several inches. 3. Open the release valve and force the saddle down as quickly as possible.
X		X	X			Jack may be low on oil. Check the oil level and refill if needed. Jack may require bleeding - see instructions on page 7.
					X	Unit may have too much hydraulic oil inside, check fluid level and adjust if needed.

## Parts List and Assembly Diagram

### Parts List

Part	Description	Qty
1	Bolt M16x140	4
2	Washer Ø16	4
3	Spring Washer Ø16	4
4	Nut M16	4
5	Spring	2
6	Bottle Jack	1
7	Bolt M8x20	2
8	Eye Bolt M8	2
9	Nut M8	2
10	Support Pin	2
11	Bolt M10x20	8
12	Washer Ø10	12

Part	Description	Qty
13	Nut M10	12
14	Bolt M10x25	4
15	Upper Beam	1
16	Frame Post	2
17	Jack Plate	1
18	Arbor Plate	2
19	Press Apron	1
20	Base Section Support	4
21	Base Section	2
22	Bottom Frame Support	1
23	Jack Handle	1

Record Product's Serial Number Here: \_\_\_\_\_

**Note:** If product has no serial number, record month and year of purchase instead.

**Note:** Some parts are listed and shown for illustration purposes only, and are not available individually as replacement parts. Specify UPC193175501592 when ordering parts.

# Assembly Diagram

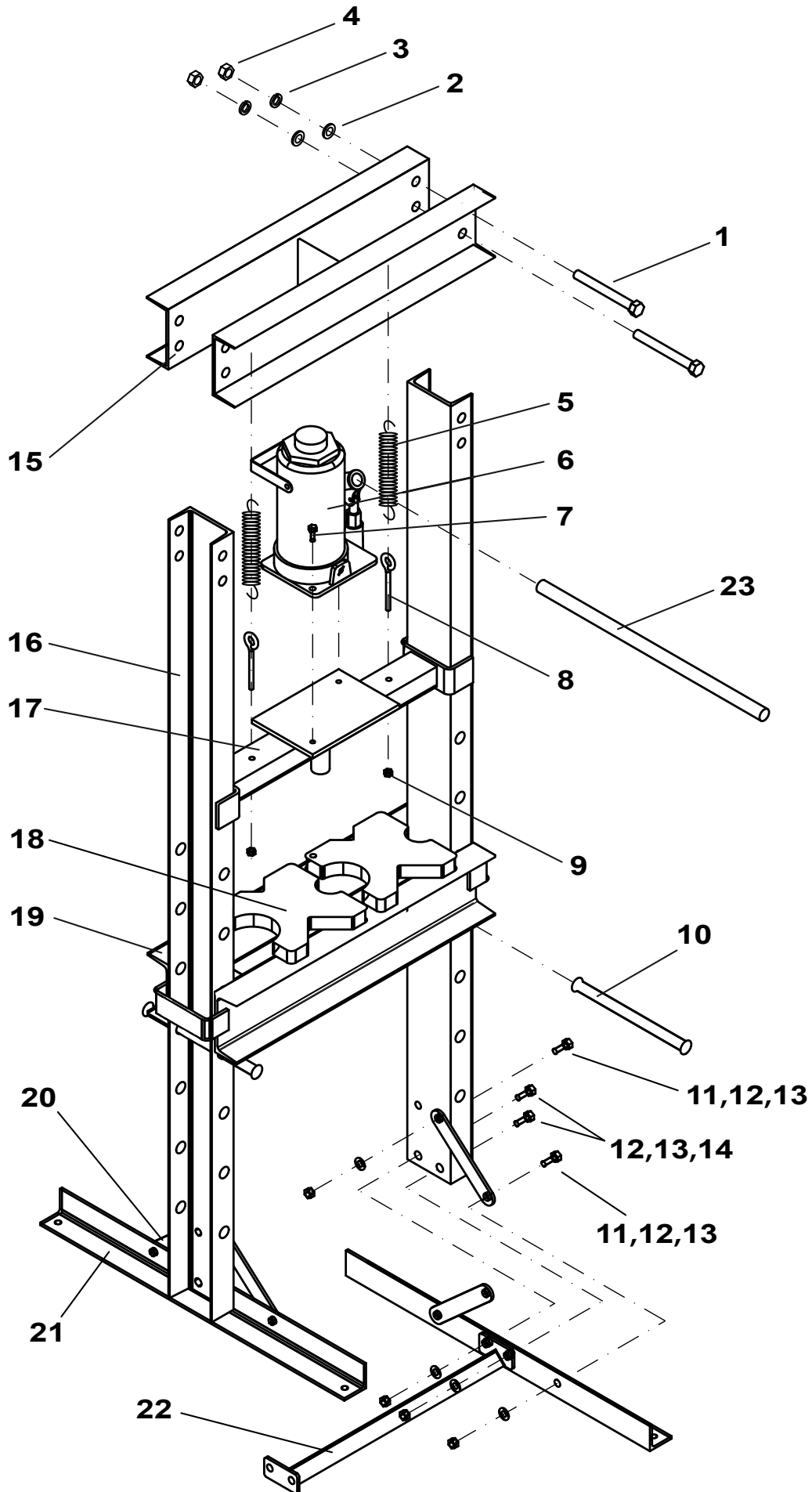

SAFETY

SETUP

OPERATION

MAINTENANCE

## PLEASE READ THE FOLLOWING CAREFULLY

---

THE MANUFACTURER AND/OR DISTRIBUTOR HAS PROVIDED THE PARTS LIST AND ASSEMBLY DIAGRAM IN THIS MANUAL AS A REFERENCE TOOL ONLY. NEITHER THE MANUFACTURER OR DISTRIBUTOR MAKES ANY REPRESENTATION OR WARRANTY OF ANY KIND TO THE BUYER THAT HE OR SHE IS QUALIFIED TO MAKE ANY REPAIRS TO THE PRODUCT, OR THAT HE OR SHE IS QUALIFIED TO REPLACE ANY PARTS OF THE PRODUCT. IN FACT, THE MANUFACTURER AND/OR DISTRIBUTOR EXPRESSLY STATES THAT ALL REPAIRS AND PARTS REPLACEMENTS SHOULD BE UNDERTAKEN BY CERTIFIED AND LICENSED TECHNICIANS, AND NOT BY THE BUYER. THE BUYER ASSUMES ALL RISK AND LIABILITY ARISING OUT OF HIS OR HER REPAIRS TO THE ORIGINAL PRODUCT OR REPLACEMENT PARTS THERETO, OR ARISING OUT OF HIS OR HER INSTALLATION OF REPLACEMENT PARTS THERETO.

### Limited 90 Day Warranty

Harbor Freight Tools Co. makes every effort to assure that its products meet high quality and durability standards, and warrants to the original purchaser that this product is free from defects in materials and workmanship for the period of 90 days from the date of purchase. This warranty does not apply to damage due directly or indirectly, to misuse, abuse, negligence or accidents, repairs or alterations outside our facilities, criminal activity, improper installation, normal wear and tear, or to lack of maintenance. We shall in no event be liable for death, injuries to persons or property, or for incidental, contingent, special or consequential damages arising from the use of our product. Some states do not allow the exclusion or limitation of incidental or consequential damages, so the above limitation of exclusion may not apply to you. THIS WARRANTY IS EXPRESSLY IN LIEU OF ALL OTHER WARRANTIES, EXPRESS OR IMPLIED, INCLUDING THE WARRANTIES OF MERCHANTABILITY AND FITNESS.

To take advantage of this warranty, the product or part must be returned to us with transportation charges prepaid. Proof of purchase date and an explanation of the complaint must accompany the merchandise. If our inspection verifies the defect, we will either repair or replace the product at our election or we may elect to refund the purchase price if we cannot readily and quickly provide you with a replacement. We will return repaired products at our expense, but if we determine there is no defect, or that the defect resulted from causes not within the scope of our warranty, then you must bear the cost of returning the product.

This warranty gives you specific legal rights and you may also have other rights which vary from state to state.

**CENTRAL<sup>®</sup>**  
**MACHINERY**

26677 Agoura Road • Calabasas, CA 91302 • 1-888-866-5797