

# HERCULES

## Owner's Manual & Safety Instructions

24f

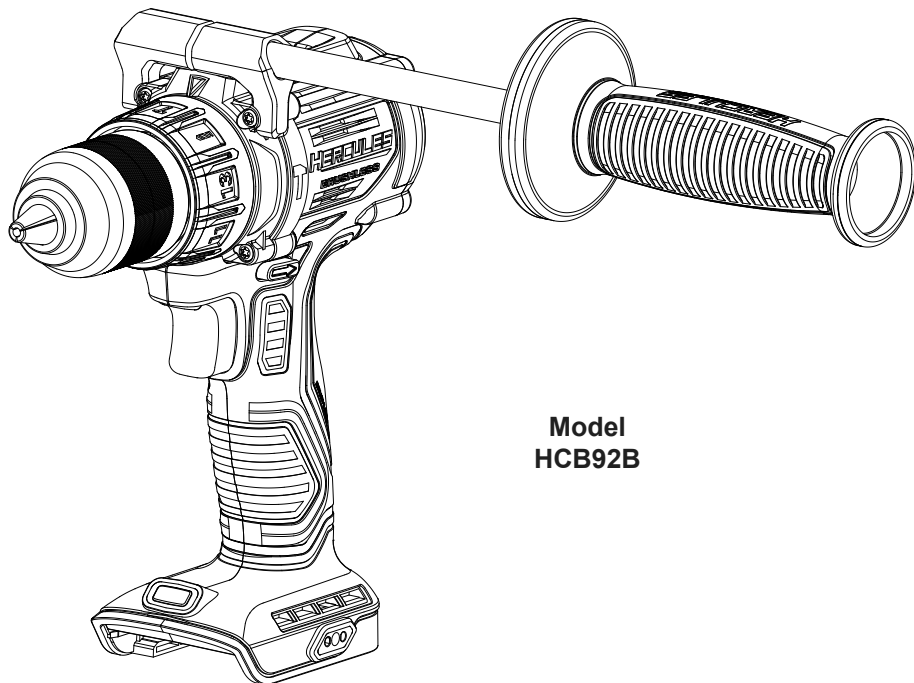

Model  
HCB92B

### 20V Brushless 1/2" Hammer Drill

**▲WARNING:** To prevent serious injury, User must read and understand Owner's Manual. **SAVE THIS MANUAL.**

When unpacking, make sure that the product is intact and undamaged.  
If any parts are missing or broken, please call 1-888-866-5797  
as soon as possible. Reference 59419.

# IMPORTANT SAFETY INFORMATION

## GENERAL POWER TOOL SAFETY WARNINGS

### **▲WARNING**

Read all safety warnings, instructions, illustrations and specifications provided with this power tool.

*Failure to follow all instructions listed below may result in electric shock, fire and/or serious injury.*

**Save all warnings and instructions for future reference.**

*The term "power tool" in the warnings refers to your mains-operated (corded) power tool or battery-operated (cordless) power tool.*

### **Work Area Safety**

1. **Keep work area clean and well lit.**  
*Cluttered or dark areas invite accidents.*
2. **Do not operate power tools in explosive atmospheres, such as in the presence of flammable liquids, gases or dust.** *Power tools create sparks which may ignite the dust or fumes.*
3. **Keep children and bystanders away while operating a power tool.**  
*Distractions can cause you to lose control.*

### **Electrical Safety**

**Do not expose power tools to rain or wet conditions.** Water entering a power tool will increase the risk of electric shock.

### **Personal Safety**

1. **Stay alert, watch what you are doing and use common sense when operating a power tool. Do not use a power tool while you are tired or under the influence of drugs, alcohol or medication.** *A moment of inattention while operating power tools may result in serious personal injury.*
2. **Use personal protective equipment. Always wear eye protection.** *Protective equipment such as dust mask, non-skid safety shoes, hard hat, or hearing protection used for appropriate conditions will reduce personal injuries.*
3. **Prevent unintentional starting. Ensure the Switch is in the off-position before connecting to power source and/or battery pack, picking up or carrying the tool.** *Carrying power tools with your finger on the Switch or energizing power tools that have the Switch on invites accidents.*
4. **Remove any adjusting key or wrench before turning the power tool on.** *A wrench or a key left attached to a rotating part of the power tool may result in personal injury.*
5. **Do not overreach. Keep proper footing and balance at all times.** *This enables better control of the power tool in unexpected situations.*
6. **Dress properly. Do not wear loose clothing or jewelry. Keep your hair, clothing and gloves away from moving parts.** *Loose clothes, jewelry or long hair can be caught in moving parts.*
7. **If devices are provided for the connection of dust extraction and collection facilities, ensure these are connected and properly used.** *Use of dust collection can reduce dust-related hazards.*
8. **Do not let familiarity gained from frequent use of tools allow you to become complacent and ignore tool safety principles.** *A careless action can cause severe injury within a fraction of a second.*
9. Only use safety equipment that has been approved by an appropriate standards agency. Unapproved safety equipment may not provide adequate protection. Eye protection must be ANSI-approved and breathing protection must be NIOSH-approved for the specific hazards in the work area.
10. Do not lay the tool down until it has come to a complete stop. Moving parts can grab the surface and pull the tool out of your control.
11. When using a handheld power tool, maintain a firm grip on the tool with both hands to resist starting torque.
12. Do not leave the tool unattended when the Battery Pack is connected. Turn off the tool, and remove the Battery Pack before leaving.

13. This product is not a toy.  
Keep it out of reach of children.
14. People with pacemakers should consult their physician(s) before use. Electromagnetic fields in close proximity to heart pacemaker could cause pacemaker interference or pacemaker failure.
15. The warnings, precautions, and instructions discussed in this instruction manual cannot cover all possible conditions and situations that may occur. It must be understood by the operator that common sense and caution are factors which cannot be built into this product, but must be supplied by the operator.

## Power Tool Use and Care

1. **Do not force the power tool. Use the correct power tool for your application.** *The correct power tool will do the job better and safer at the rate for which it was designed.*
2. **Do not use the power tool if the Switch does not turn it on and off.** *Any power tool that cannot be controlled with the Switch is dangerous and must be repaired.*
3. **Disconnect the plug from the power source and/or remove the battery pack, if detachable, from the power tool before making any adjustments, changing accessories, or storing power tools.** *Such preventive safety measures reduce the risk of starting the power tool accidentally.*
4. **Store idle power tools out of the reach of children and do not allow persons unfamiliar with the power tool or these instructions to operate the power tool.** *Power tools are dangerous in the hands of untrained users.*
5. **Maintain power tools and accessories.** **Check for misalignment or binding of moving parts, breakage of parts and any other condition that may affect the power tool's operation.** **If damaged, have the power tool repaired before use.** *Many accidents are caused by poorly maintained power tools.*
6. **Keep cutting tools sharp and clean.** *Properly maintained cutting tools with sharp cutting edges are less likely to bind and are easier to control.*
7. **Use the power tool, accessories and tool bits etc. in accordance with these instructions, taking into account the working conditions and the work to be performed.** *Use of the power tool for operations different from those intended could result in a hazardous situation.*
8. **Keep handles and grasping surfaces dry, clean and free from oil and grease.** *Slippery handles and grasping surfaces do not allow for safe handling and control of the tool in unexpected situations.*

## Service

1. **Have your power tool serviced by a qualified repair person using only identical replacement parts.** *This will ensure that the safety of the power tool is maintained.*
2. **Never service damaged BATTERY packs.** *Service of BATTERY packs should only be performed by the manufacturer or authorized service providers.*
3. **Maintain labels and nameplates on the tool.** **These carry important safety information.** **If unreadable or missing, contact Harbor Freight Tools for a replacement.**

## Battery Tool Use and Care

1. **Prevent unintentional starting.** *Ensure the switch is in the off-position before connecting to battery pack, picking up or carrying the power tool. Carrying the power tool with your finger on the switch or energizing power tool that have the switch on invites accidents.*
2. **Disconnect the battery pack from the power tool before making any adjustments, changing accessories, or storing power tool.** *Such preventive safety measures reduce the risk of starting the power tool accidentally.*
3. **Recharge only with the charger specified by the manufacturer.** *A charger that is suitable for one type of battery pack may create a risk of fire when used with another battery pack.*
4. **Use power tools only with specifically designated battery packs.** *Use of any other battery packs may create a risk of injury and fire.*
5. **When battery pack is not in use, keep it away from other metal objects, like paper clips, coins, keys, nails, screws or other small metal objects, that can make a connection from one terminal to another.** *Shorting the battery terminals together may cause burns or a fire.*
6. **Under abusive conditions, liquid may be ejected from the battery; avoid contact.** *If contact accidentally occurs, flush with water. If liquid contacts eyes, additionally seek medical help. Liquid ejected from the battery may cause irritation or burns.*
7. **Do not use a battery pack or power tool that is damaged or modified.** *Damaged or modified batteries may exhibit unpredictable behavior resulting in fire, explosion or risk of injury.*
8. **Do not expose a battery pack or power tool to fire or excessive temperature.** *Exposure to fire or temperature above 140° F may cause explosion.*

9. Follow all charging instructions and do not charge the battery pack or power tool outside of the temperature range specified in the instructions. *Charging improperly or at temperatures outside of the specified range may damage the battery and increase the risk of fire.*

10. Have servicing performed by a qualified repair person using only identical replacement parts. *This will ensure that the safety of the product is maintained.*

11. Do not modify or attempt to repair the power tool or the battery pack except as indicated in the instructions for use and care.

12.  The battery Charger gets hot during use. The Charger's heat can build up to unsafe levels and create a fire hazard if it does not receive adequate ventilation, due to an electrical fault, or if it is used in a hot environment. Do not place the Charger on a flammable surface. Do not obstruct any vents on the Charger. **Especially avoid placing the Charger on carpets and rugs; they are not only flammable, but they also obstruct vents under the Charger.** Place the Charger on a stable, solid, nonflammable surface (such as a stable metal workbench or concrete floor) at least 1 foot away from all flammable objects, such as drapes or walls. Keep a fire extinguisher and a smoke detector in the area. Frequently monitor the Charger and Battery Pack while charging.

### Lithium Battery Safety Warnings



**LITHIUM BATTERIES  
STORE A LARGE AMOUNT  
OF ENERGY AND WILL  
VENT FIRE OR EXPLODE IF MISTREATED:**

1. Keep Battery Pack dry.
2. DO NOT DO ANY OF THE FOLLOWING TO THE BATTERY PACK:
  - Open
  - Drop
  - Short-circuit
  - Puncture
  - Incinerate
  - **Expose to temperatures greater than 140°F.**
3. Charge Battery Pack only according to instructions.
4. Inspect Battery Pack before every use; do not use or charge if damaged.

### Safety Instructions for All Operations

1. **Wear ear protectors when hammer drilling.** *Exposure to noise can cause hearing loss.*
2. **Use the auxiliary handle.** *Loss of control can cause personal injury.*
3. **Brace the tool properly before use.** *This tool produces a high output torque and without properly bracing the tool during operation, loss of control may occur resulting in personal injury.*
4. **Hold the power tool by insulated gripping surfaces, when performing an operation where the cutting accessory or fasteners may contact hidden wiring or its own cord.** *Cutting accessory contacting a "live" wire may make exposed metal parts of the power tool "live" and could give the operator an electric shock.*
5. Let bit cool before touching, changing or adjusting it. Bits heat up dramatically while in use, and can burn you.
6. If the drill bit jams, release the Switch immediately; drill torque can cause injury or break bit.

### Safety Instructions When Using Long Drill Bits

1. **Never operate at higher speed than the maximum speed rating of the drill bit.** *At higher speeds, the bit is likely to bend if allowed to rotate freely without contacting the workpiece, resulting in personal injury.*
2. **Always start drilling at low speed and with the bit tip in contact with the workpiece.** *At higher speeds, the bit is likely to bend if allowed to rotate freely without contacting the workpiece, resulting in personal injury.*
3. **Apply pressure only in direct line with the bit and do not apply excessive pressure.** *Bits can bend causing breakage or loss of control, resulting in personal injury.*

### Silicosis Safety Measures

Masonry drilling on materials such as concrete (which contains crystalline silica) can cause silicosis (a serious lung disease), cancer and death. To reduce crystalline silica exposures in the workplace and prevent silicosis and silicosis-related deaths:

- a. Conduct air monitoring to measure worker exposures.
- b. Use containment methods to control the hazard and protect adjacent workers from exposure.
- c. Practice good personal hygiene to avoid unnecessary exposure to silica dust.

- d. Wear washable or disposable protective clothes at the work site. Shower and change into clean clothes before leaving the work site to prevent contamination of cars, homes and other work areas. Avoid skin exposure.
- e. Always wear a NIOSH approved respirator and safety goggles. Ventilate the work area properly.
- f. Provide periodic medical examinations for all workers who may be exposed to crystalline silica.
- g. Post signs to warn workers about the hazard and to inform them about required protective equipment.
- h. Provide workers with training that includes information about health effects, work practices and protective equipment for crystalline silica.
- i. Report all cases of silicosis to State health departments and to OSHA or the Mine Safety and Health Administration (MSHA).

## GROUNDING

### ⚠️ WARNING



**TO PREVENT ELECTRIC SHOCK AND DEATH FROM INCORRECT GROUNDING: Check with a qualified electrician if you are in doubt as to whether the outlet is properly grounded. Do not modify the power cord plug provided with the charger. Do not use the charger if the power cord or plug is damaged. If damaged, have it repaired by a service facility before use. If the plug will not fit the outlet, have a proper outlet installed by a qualified electrician.**

### Extension Cords

Extension cords must not be used with this item's Charger.

### Vibration Safety

This tool vibrates during use.

Repeated or long-term exposure to vibration may cause temporary or permanent physical injury, particularly to the hands, arms and shoulders.

To reduce the risk of vibration-related injury:

1. Anyone using vibrating tools regularly or for an extended period should first be examined by a doctor and then have regular medical check-ups to ensure medical problems are not being caused or worsened from use. Pregnant women or people who have impaired blood circulation to the hand, past hand injuries, nervous system disorders, diabetes, or Raynaud's Disease should not use this tool. If you feel any symptoms related to vibration (such as tingling, numbness, and white or blue fingers), seek medical advice as soon as possible.
2. Do not smoke during use. Nicotine reduces the blood supply to the hands and fingers, increasing the risk of vibration-related injury.
3. Wear suitable gloves to reduce the vibration effects on the user.
4. Use tools with the lowest vibration when there is a choice.
5. Include vibration-free periods each day of work.
6. Grip tool as lightly as possible (while still keeping safe control of it). Let the tool do the work.
7. To reduce vibration, maintain the tool as explained in this manual. If any abnormal vibration occurs, stop use immediately.



**SAVE THESE INSTRUCTIONS**

### Symbology

<b>V</b>	Volts
<b>≡</b>	Direct Current
<b>A</b>	Amperes
n <sub>0</sub> xxxx/min.	No Load Revolutions per Minute (RPM)
	WARNING marking concerning Risk of Eye Injury. Wear ANSI-approved safety goggles with side shields.
	Read the manual before set-up and/or use.
	WARNING marking concerning Risk of Hearing Loss. Wear hearing protection.
	WARNING marking concerning Risk of Fire. Do not cover Charger ventilation ducts. Charge on fireproof surface only.
	WARNING marking concerning Risk of Explosion. Do not puncture, short, or open battery packs and do not charge damaged battery packs.
	WARNING marking concerning Risk of Electric Shock. Properly connect Charger's power cord to appropriate outlet.

## SPECIFICATIONS

Battery Type	Hercules 20V Li-ion
Charger Type	Hercules 20V Li-ion
No Load Speed	n <sub>0</sub> : 0-550/0-2000/min
BPM	0-8800/0-32,000
Max Torque	1200 in-lb
Chuck Size	1/2"
Steel Capacity	1/2"
Wood Capacity (Spade Bit)	1-1/2"
Wood Capacity (Self Feed Bit)	2-9/16"
Masonry Capacity	5/8"

## Warning Symbols and Definitions

**!** This is the safety alert symbol. It is used to alert you to potential personal injury hazards. Obey all safety messages that follow this symbol to avoid possible injury or death.

**! DANGER** Indicates a hazardous situation which, if not avoided, will result in death or serious injury.

**! WARNING** Indicates a hazardous situation which, if not avoided, could result in death or serious injury.

**! CAUTION** Indicates a hazardous situation which, if not avoided, could result in minor or moderate injury.

**NOTICE** Addresses practices not related to personal injury.

## SETUP—BEFORE USE



Read the **ENTIRE IMPORTANT SAFETY INFORMATION** section at the beginning of this manual including all text under subheadings therein before set up or use of this product.

## Functional Description

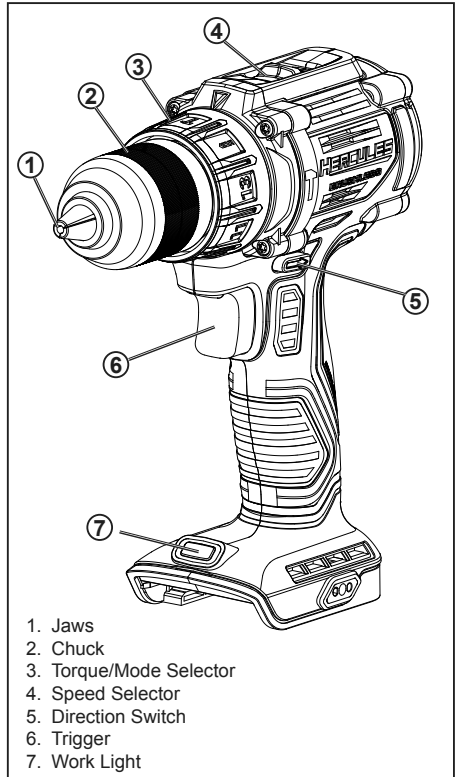

1. Jaws
2. Chuck
3. Torque/Mode Selector
4. Speed Selector
5. Direction Switch
6. Trigger
7. Work Light

## OPERATION



Read the **ENTIRE IMPORTANT SAFETY INFORMATION** section at the beginning of this manual including all text under subheadings therein before set up or use of this product.

## Tool Set Up

### **WARNING**

**TO PREVENT SERIOUS INJURY FROM ACCIDENTAL OPERATION:**

**Make sure that the Trigger is locked and Battery Pack is removed before performing any procedure in this section.**

### *Charging Battery Pack*

Charge battery after unpacking and before using this tool. Follow instructions included with battery charger.

### *Attaching Belt Clip, Bit Holder, and Lanyard*

1. Attach Belt Clip to either side of the Handle using supplied Screw.
2. Attach Bit Holder to the other side of the Handle using supplied Screw.

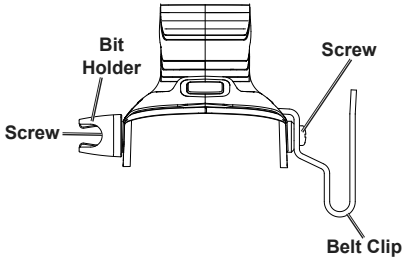

3. Attach Lanyard (sold separately) to the Lanyard Loop.

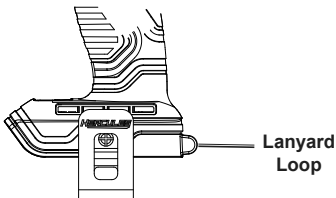

## Side Handle

1. Side Handle may be positioned on either side.
2. Loosen the side handle grip until the jaws are far enough apart to fit over screw bosses on the gear housing.
3. Tighten the handle grip until it is secure. Pull on Side Handle to make sure it is securely attached. Tighten handle grip as necessary.

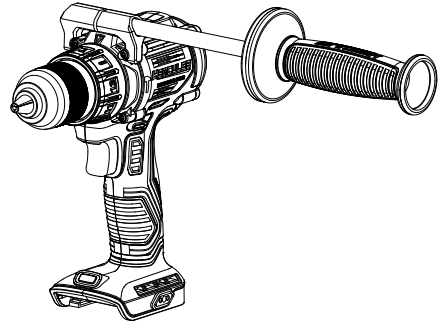
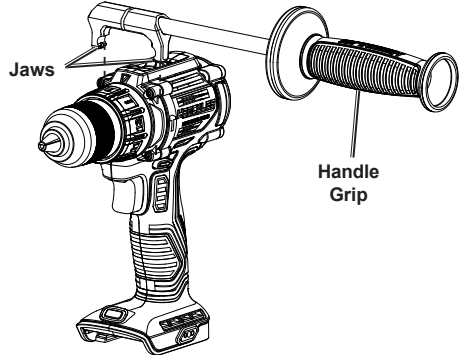

## Bit Installation

**CAUTION!** Wear heavy-duty work gloves to provide protection when inserting and removing bits. Bits become very hot during use. Do not remove bit until it has cooled.

**NOTICE:** Use sharp bits. Dull, bent, or damaged bits will cause stress on the drill and/or break.

1. Rotate Chuck counterclockwise until Jaws are opened enough for bit to fit.
2. Use a bit designed for workpiece type. Place desired drill, screwdriver, bolt or nut bit into Jaws.

**Note:** In addition to single or double-ended bits, hex shaft adapters with matching socket heads can also be used.

3. Rotate Chuck clockwise until bit is held securely in place, centered between Jaws.

## Mode Selection

Rotate Mode Selector so arrow is pointing to desired mode.

### Drilling

Drilling in wood and metal.

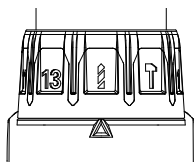

#### Drilling in Wood

1. Use high speed steel, high speed steel with TiN coating, or carbon steel drill bits for wood drilling. Use drill bit type appropriate for application.
2. Start wood drilling at very low speed to keep the bit from slipping. Increase speed as drill bit bites into wood.
3. When drilling through holes, place a block of wood behind the workpiece to prevent ragged edges on the back side of the hole.

#### Drilling in Metal

1. Use high speed steel, or TiN coated high speed steel drill bits for metal drilling. Use drill bit type appropriate for application.

**Note:** When drilling in metal, be sure to lubricate bits with cutting oil to improve drilling action and extend bit life.

2. Start metal drilling at very low speed to keep the bit from slipping. Maintain the speed and pressure, allowing for cutting without overheating the bit.
3. When drilling large holes in metal surfaces, use a small drill bit at first. Then finish with a larger drill bit.

## Driving

Driving screws, bolts and installing nuts.

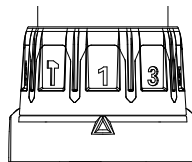

1. Set torque by rotating Torque Selector.
2. Use the numbered torque settings from 1 to 14\* for driving screws, bolts and nuts.

**Note:** Although the numbers only go up to 13, there is a 14th setting just beyond that. The ring must be set in a specific setting before use to avoid damaging the tool.

- The torque setting required depends on the object being driven. In the case of screws, consider the size, length, and type of material.
- If a pilot hole has been drilled into the material, a lower torque setting will be required.
- Adjust the torque setting low enough to allow a safety margin. Use a very low torque setting when first driving small screws into soft materials. Then adjust the setting as the proper force required is determined.
- Clutch settings 1-5 have a soft start feature that ramps up the speed slowly.

## Hammer Drilling

Drilling in masonry.

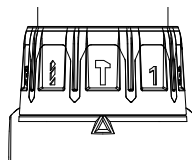

#### Drilling in Masonry

1. Use carbide or specialty bits for masonry drilling and set mode to Hammer Drilling.

**NOTE:** In deep bore holes, occasionally pull the drill bit out to remove dust and chips.

## Speed Selection

Adjust Speed Selector to proper setting:

- Low Speed: Select 1
- High Speed: Select 2

**Note:** Make sure the tool comes to a complete stop before changing speeds.



## Direction Switch

**Forward:** Push Switch in on right side (arrow pointing forward) for clockwise rotation.

**Reverse:** Push Switch in on left side (arrow pointing backward) for counter-clockwise rotation.

**Trigger Lock:** Push Switch to the center to lock the Trigger.

**CAUTION!** Set Control Switch to center Trigger Lock position during set up, when changing bits or when tool is idle.

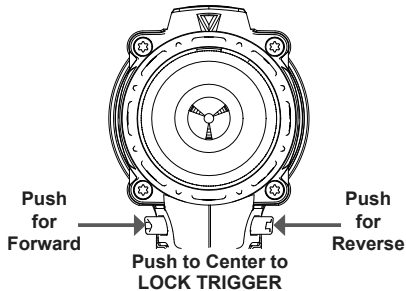

## Workpiece and Work Area Set Up

**Note:** A pilot hole may be required for your workpiece.

1. Designate a work area that is clean and well lit. The work area must not allow access by children or pets to prevent distraction and injury.
2. Secure loose workpieces using a vise or clamps (not included) to prevent movement while working.
3. There must not be objects, such as utility lines, nearby that will present a hazard while working.

## General Operation

1. Lock Trigger, then insert a fully charged Battery Pack, making sure that it clicks into place securely.
2. Install Bit, select Mode, Speed and Direction of Rotation.

**NOTICE:** Do not change direction of rotation while Chuck is rotating. Wait until Chuck has come to a complete stop before changing direction.

3. Press Trigger to start the tool. The Work Light will turn on when Trigger is pressed and turn off when Trigger is released.
4. The tool has variable speed. To increase speed, apply more pressure to Trigger. To decrease speed, lessen pressure on Trigger.

## Driving

1. When inserting or removing a screw or bolt, use pressure at first to keep the bit in the head of the screw or bolt and cause the screw or bolt to thread into or unthread from the material.

**Note:** The amount of actual torque will vary depending on the cleanliness and condition of the threads and other factors. If tightening critical components, chase threads before assembling components and check the actual torque applied to the fastener with a mechanical torque wrench (not included).

2. When finished using the Tool, release Trigger and center Direction Switch to lock Trigger.
3. To prevent accidents, remove tool's Battery Pack after use. Clean, then store the tool indoors out of children's reach.

## Drilling

**CAUTION!** Most drill bits are designed for use in the forward, clockwise direction. Do not use a drill bit in the opposite direction than it is designed for.

1. When drilling a hole, let the tool do the work, using only enough pressure to follow the drill as it cuts the hole in the material.
2. When drilling a hard, smooth surface, use a center punch (not included) to mark the desired hole.
3. After the Drill bit cuts through the workpiece, remove it while the Drill is still running. This prevents the Drill bit from binding. **IF THE BIT STARTS TO BIND, RELEASE TRIGGER IMMEDIATELY!** Allow Drill to come to a full stop, then, using the Direction Switch, set Drill to Reverse direction and slowly reverse bit out of workpiece.
4. When finished using the Tool, release Trigger and center Direction Switch to lock Trigger.
5. To prevent accidents, remove tool's Battery Pack after use. Clean, then store the tool indoors out of children's reach.

## MAINTENANCE AND SERVICING



Procedures not specifically explained in this manual must be performed only by a qualified technician.

### **!WARNING**

#### **TO PREVENT SERIOUS INJURY FROM ACCIDENTAL OPERATION:**

**Make sure the Trigger is locked and Battery Pack is removed before performing any procedure in this section.**

#### **TO PREVENT SERIOUS INJURY FROM TOOL FAILURE:**

**Do not use damaged equipment. If abnormal noise or vibration occurs or damage is noted, have the problem corrected before further use.**

## *Cleaning, Maintenance, and Lubrication*

1. **BEFORE EACH USE**, inspect the general condition of the Tool, Charger. Check for:
  - leaking, swollen, or cracked Battery Pack,
  - loose hardware,
  - misalignment or binding of moving parts,
  - cracked or broken parts,
  - damaged electrical wiring,
  - any other condition that may affect its safe operation.
2. **AFTER USE**, wipe external surfaces of the Tool with clean cloth.
3. **Li-ion BATTERY MUST BE RECYCLED OR DISPOSED OF PROPERLY.**  
Do not short, incinerate or open battery.
4. Disconnect Battery Pack and store Battery Pack, Charger, and Tool in dry, indoor area out of reach of children and away from metal objects (i.e., paperclips, coins) to prevent shorting.

## Troubleshooting

Problem	Possible Causes	Likely Solutions
Tool will not start.	<ol style="list-style-type: none"> <li>1. Battery Pack not properly connected.</li> <li>2. Battery Pack not properly charged.</li> <li>3. Battery Pack stopped working.</li> <li>4. Internal damage or wear. (Switch, for example.)</li> </ol>	<ol style="list-style-type: none"> <li>1. Remove Battery Pack, make sure there are no obstructions, clean battery contacts on tool, reinsert the Battery Pack and press firmly until the Battery Pack locks in place.</li> <li>2. Make sure Charger is connected and operating properly. Give enough time for Battery Pack to recharge properly.</li> <li>3. Dispose of old Battery Pack properly or recycle. Replace Battery Pack.</li> <li>4. Have technician service tool.</li> </ol>
Tool operates slowly.	<ol style="list-style-type: none"> <li>1. Forcing tool to work too fast.</li> <li>2. Battery Pack wearing out.</li> </ol>	<ol style="list-style-type: none"> <li>1. Allow tool to work at its own rate.</li> <li>2. Dispose of old Battery Pack properly or recycle. Replace Battery Pack.</li> </ol>
Performance decreases over time.	Bit dull or damaged.	Keep bits sharp. Replace as needed.
Excessive noise or rattling.	Internal damage or wear.	Have technician service tool.
Overheating.	<ol style="list-style-type: none"> <li>1. Forcing tool to work too fast.</li> <li>2. Bit dull or damaged.</li> <li>3. Blocked motor housing vents.</li> </ol>	<ol style="list-style-type: none"> <li>1. Allow tool to work at its own rate.</li> <li>2. Keep bits sharp. Replace as needed.</li> <li>3. Wear ANSI-approved safety goggles and NIOSH-approved dust mask/respirator while blowing dust out of motor using compressed air.</li> </ol>
 <p><b>Follow all safety precautions whenever diagnosing or servicing the tool. Disconnect Battery Pack and Charger power supply before service.</b></p>		

Record Product's Serial Number Here: \_\_\_\_\_

**Note:** If product has no serial number, record month and year of purchase instead.

**Note:** Replacement parts may be available for this item.

Visit [harborfreight.com/parts](http://harborfreight.com/parts) for a list of in stock parts. Reference UPC 193175469946.

## 5-YEAR LIMITED WARRANTY

This Hercules tool is warranted to the original purchaser to be free from defects in materials and workmanship for a period of five (5) years beginning on the date of purchase. This warranty does not cover battery packs and battery chargers, which are covered under separate warranties. To obtain warranty service, visit your local Harbor Freight retail store. Warranty registration is not required. The product or part must be returned to us with proof of purchase (e.g. in-store receipt or packing slip/invoice) and may require shipment by purchaser to a service center at purchaser's expense. If our inspection verifies a covered defect in materials or workmanship during the warranty period, we will, at our option, repair or replace the defective product. We will return repaired products within a reasonable time at our expense, but if we determine that there is no defect, or that the defect resulted from causes not within the scope of our warranty, then we will return the product to you if you pay return shipping costs.

This warranty does not cover any failure or damage that we determine is due directly or indirectly to normal wear and tear, misuse, use not for the intended purpose or not in accordance with the product manual, abuse, accident, rental, modification or alteration, unauthorized repair, improper installation, neglect, lack of maintenance, or any other failure not arising from defective materials or workmanship. Fraudulent returns or claims will be denied. The repair or replacement described in this warranty shall be your sole and exclusive remedy. THIS WARRANTY IS EXCLUSIVE AND IN LIEU OF ALL OTHER EXPRESS WARRANTIES, WRITTEN OR ORAL, AND ANY IMPLIED WARRANTIES ARE DISCLAIMED TO THE EXTENT PERMITTED BY LAW AND OTHERWISE LIMITED TO THE DURATION OF THE EXPRESS WARRANTY HEREIN. HARBOR FREIGHT SHALL NOT BE LIABLE UNDER ANY CIRCUMSTANCES FOR ANY INCIDENTAL, INDIRECT, SPECIAL, CONSEQUENTIAL, OR PUNITIVE DAMAGES OR COSTS ARISING FROM THIS WARRANTY OR THE USE OF THIS PRODUCT. SOME STATES DO NOT ALLOW LIMITATIONS ON HOW LONG AN IMPLIED WARRANTY LASTS OR THE EXCLUSION OR LIMITATION OF INCIDENTAL OR CONSEQUENTIAL DAMAGES, SO THESE LIMITATIONS MAY NOT APPLY TO YOU. THIS WARRANTY GIVES YOU SPECIFIC LEGAL RIGHTS, AND YOU MAY ALSO HAVE OTHER RIGHTS WHICH VARY FROM STATE TO STATE.

Visit our website at: <http://www.harborfreight.com>

Email our technical support at: [productsupport@harborfreight.com](mailto:productsupport@harborfreight.com)

For technical questions, please call 1-888-866-5797

---

Copyright© 2022 by Harbor Freight Tools®. All rights reserved. No portion of this manual or any artwork contained herein may be reproduced in any shape or form without the express written consent of Harbor Freight Tools. Diagrams within this manual may not be drawn proportionally. Due to continuing improvements, actual product may differ slightly from the product described herein. Tools required for assembly and service may not be included.

# **HERCULES**

26677 Agoura Road • Calabasas, CA 91302 • 1-888-866-5797



**Model  
HCB81B**

### **20V Brushless 1/4" Impact Driver**

**▲WARNING:** To prevent serious injury, User must read and understand Owner's Manual. **SAVE THIS MANUAL.**

When unpacking, make sure that the product is intact and undamaged.  
If any parts are missing or broken, please call 1-888-866-5797  
as soon as possible. Reference 59421.

# IMPORTANT SAFETY INFORMATION

## GENERAL POWER TOOL SAFETY WARNINGS

### **▲WARNING**

Read all safety warnings, instructions, illustrations and specifications provided with this power tool. *Failure to follow all instructions listed below may result in electric shock, fire and/or serious injury.*

**Save all warnings and instructions for future reference.**

*The term "power tool" in the warnings refers to your mains-operated (corded) power tool or battery-operated (cordless) power tool.*

### **Work Area Safety**

1. **Keep work area clean and well lit.**  
*Cluttered or dark areas invite accidents.*
2. **Do not operate power tools in explosive atmospheres, such as in the presence of flammable liquids, gases or dust.** *Power tools create sparks which may ignite the dust or fumes.*
3. **Keep children and bystanders away while operating a power tool.**  
*Distractions can cause you to lose control.*

### **Electrical Safety**

**Do not expose power tools to rain or wet conditions.** *Water entering a power tool will increase the risk of electric shock.*

### **Personal Safety**

1. **Stay alert, watch what you are doing and use common sense when operating a power tool. Do not use a power tool while you are tired or under the influence of drugs, alcohol or medication.** *A moment of inattention while operating power tools may result in serious personal injury.*
2. **Use personal protective equipment. Always wear eye protection.** *Protective equipment such as dust mask, non-skid safety shoes, hard hat, or hearing protection used for appropriate conditions will reduce personal injuries.*
3. **Prevent unintentional starting. Ensure the Trigger is in the off-position before connecting to power source, picking up or carrying the tool.** *Carrying power tools with your finger on the Trigger or energizing power tools that have the Trigger on invites accidents.*
4. **Remove any adjusting key or wrench before turning the power tool on.** *A wrench or a key left attached to a rotating part of the power tool may result in personal injury.*
5. **Do not overreach. Keep proper footing and balance at all times.** *This enables better control of the power tool in unexpected situations.*
6. **Dress properly. Do not wear loose clothing or jewelry. Keep your hair, clothing and gloves away from moving parts.** *Loose clothes, jewelry or long hair can be caught in moving parts.*
7. **If devices are provided for the connection of dust extraction and collection facilities, ensure these are connected and properly used.** *Use of dust collection can reduce dust-related hazards.*
8. **Do not let familiarity gained from frequent use of tools allow you to become complacent and ignore tool safety principles.** *A careless action can cause severe injury within a fraction of a second.*
9. Only use safety equipment that has been approved by an appropriate standards agency. Unapproved safety equipment may not provide adequate protection. Eye protection must be ANSI-approved and breathing protection must be NIOSH-approved for the specific hazards in the work area.
10. Do not lay the tool down until it has come to a complete stop. Moving parts can grab the surface and pull the tool out of your control.
11. When using a handheld power tool, maintain a firm grip on the tool with both hands to resist starting torque.
12. Do not leave the tool unattended when the Battery Pack is connected. Turn off the tool, and remove the Battery Pack before leaving.
13. This product is not a toy. Keep it out of reach of children.
14. People with pacemakers should consult their physician(s) before use. Electromagnetic fields in close proximity to heart pacemaker could cause pacemaker interference or pacemaker failure.
15. The warnings, precautions, and instructions discussed in this instruction manual cannot cover all possible conditions and situations that may occur. It must be understood by the operator that common sense and caution are factors which cannot be built into this product, but must be supplied by the operator.

## Power Tool Use and Care

1. **Do not force the power tool. Use the correct power tool for your application.** *The correct power tool will do the job better and safer at the rate for which it was designed.*
2. **Do not use the power tool if the Trigger does not turn it on and off.** *Any power tool that cannot be controlled with the Trigger is dangerous and must be repaired.*
3. **Disconnect the plug from the power source and/or remove the battery pack, if detachable, from the power tool before making any adjustments, changing accessories, or storing power tools.** *Such preventive safety measures reduce the risk of starting the power tool accidentally.*
4. **Store idle power tools out of the reach of children and do not allow persons unfamiliar with the power tool or these instructions to operate the power tool.** *Power tools are dangerous in the hands of untrained users.*
5. **Maintain power tools and accessories. Check for misalignment or binding of moving parts, breakage of parts and any other condition that may affect the power tool's operation. If damaged, have the power tool repaired before use.** *Many accidents are caused by poorly maintained power tools.*
6. **Keep cutting tools sharp and clean.** *Properly maintained cutting tools with sharp cutting edges are less likely to bind and are easier to control.*
7. **Use the power tool, accessories and tool bits etc. in accordance with these instructions, taking into account the working conditions and the work to be performed.** *Use of the power tool for operations different from those intended could result in a hazardous situation.*
8. **Keep handles and grasping surfaces dry, clean and free from oil and grease.** *Slippery handles and grasping surfaces do not allow for safe handling and control of the tool in unexpected situations.*

## Service

1. **Have your power tool serviced by a qualified repair person using only identical replacement parts.** *This will ensure that the safety of the power tool is maintained.*
2. **Never service damaged BATTERY packs.** *Service of BATTERY packs should only be performed by the manufacturer or authorized service providers.*
3. **Maintain labels and nameplates on the tool.** *These carry important safety information. If unreadable or missing, contact Harbor Freight Tools for a replacement.*

## Battery Tool Use and Care

1. **Prevent unintentional starting.** *Ensure the switch is in the off-position before connecting to battery pack, picking up or carrying the power tool. Carrying the power tool with your finger on the switch or energizing power tool that have the switch on invites accidents.*
2. **Disconnect the battery pack from the power tool before making any adjustments, changing accessories, or storing power tool.** *Such preventive safety measures reduce the risk of starting the power tool accidentally.*
3. **Recharge only with the charger specified by the manufacturer.** *A charger that is suitable for one type of battery pack may create a risk of fire when used with another battery pack.*
4. **Use power tools only with specifically designated battery packs.** *Use of any other battery packs may create a risk of injury and fire.*
5. **When battery pack is not in use, keep it away from other metal objects, like paper clips, coins, keys, nails, screws or other small metal objects, that can make a connection from one terminal to another.** *Shorting the battery terminals together may cause burns or a fire.*
6. **Under abusive conditions, liquid may be ejected from the battery; avoid contact.** *If contact accidentally occurs, flush with water. If liquid contacts eyes, additionally seek medical help. Liquid ejected from the battery may cause irritation or burns.*
7. **Do not use a battery pack or power tool that is damaged or modified.** *Damaged or modified batteries may exhibit unpredictable behavior resulting in fire, explosion or risk of injury.*
8. **Do not expose a battery pack or power tool to fire or excessive temperature.** *Exposure to fire or temperature above 140°F may cause explosion.*
9. **Follow all charging instructions and do not charge the battery pack or power tool outside of the temperature range specified in the instructions.** *Charging improperly or at temperatures outside of the specified range may damage the battery and increase the risk of fire.*
10. **Have servicing performed by a qualified repair person using only identical replacement parts.** *This will ensure that the safety of the product is maintained.*
11. **Do not modify or attempt to repair the power tool or the battery pack except as indicated in the instructions for use and care.**

12.  The battery Charger gets hot during use. The Charger's heat can build up to unsafe levels and create a fire hazard if it does not receive adequate ventilation, due to an electrical fault, or if it is used in a hot environment. Do not place the Charger on a flammable surface. Do not obstruct any vents on the Charger. **Especially avoid placing the Charger on carpets and rugs; they are not only flammable, but they also obstruct vents under the Charger.** Place the Charger on a stable, solid, nonflammable surface (such as a stable metal workbench or concrete floor) at least 1 foot away from all flammable objects, such as drapes or walls. Keep a fire extinguisher and a smoke detector in the area. Frequently monitor the Charger and Battery Pack while charging.

### Lithium Battery Safety Warnings



**LITHIUM BATTERIES  
STORE A LARGE AMOUNT  
OF ENERGY AND WILL  
VENT FIRE OR EXPLODE IF MISTREATED:**

1. Keep Battery Pack dry.
2. DO NOT DO ANY OF THE FOLLOWING TO THE BATTERY PACK:
  - **Open,**
  - **Drop,**
  - **Short-circuit,**
  - **Puncture,**
  - **Incinerate, or**
  - **Expose to temperatures greater than 140°F.**
3. Charge Battery Pack only according to its Charger's instructions.
4. Inspect Battery Pack before every use; do not use or charge if damaged.

### Impact Driver Safety Warnings

1. **Hold power tools by insulated gripping surfaces, when performing an operation where the fastener may contact hidden wiring. Fasteners contacting a "live" wire will make exposed metal parts of the power tool "live" and could give the operator an electric shock.**
2. When using a handheld power tool, maintain a firm grip on the tool with both hands to resist starting torque.

### Vibration Safety

This tool vibrates during use.

Repeated or long-term exposure to vibration may cause temporary or permanent physical injury, particularly to the hands, arms and shoulders. To reduce the risk of vibration-related injury:

1. Anyone using vibrating tools regularly or for an extended period should first be examined by a doctor and then have regular medical check-ups to ensure medical problems are not being caused or worsened from use. Pregnant women or people who have impaired blood circulation to the hand, past hand injuries, nervous system disorders, diabetes, or Raynaud's Disease should not use this tool. If you feel any symptoms related to vibration (such as tingling, numbness, and white or blue fingers), seek medical advice as soon as possible.
2. Do not smoke during use. Nicotine reduces the blood supply to the hands and fingers, increasing the risk of vibration-related injury.
3. Wear suitable gloves to reduce the vibration effects on the user.
4. Use tools with the lowest vibration when there is a choice.
5. Include vibration-free periods each day of work.
6. Grip tool as lightly as possible (while still keeping safe control of it). Let the tool do the work.
7. To reduce vibration, maintain the tool as explained in this manual. If any abnormal vibration occurs, stop use immediately.



**SAVE THESE  
INSTRUCTIONS**



## GROUNDING

### **⚠️ WARNING**



**TO PREVENT ELECTRIC SHOCK AND DEATH FROM INCORRECT GROUNDING:** Check with a qualified electrician if you are in doubt as to whether the outlet is properly grounded. Do not modify the power cord plug provided with the charger. Do not use the charger if the power cord or plug is damaged. If damaged, have it repaired by a service facility before use. If the plug will not fit the outlet, have a proper outlet installed by a qualified electrician.

## Extension Cords

Extension cords must not be used with this item's Charger.

### Symbology

<b>V</b>	Volts
	Direct Current
<b>A</b>	Amperes
n <sub>0</sub> xxxx/min.	No Load Revolutions per Minute (RPM)
	WARNING marking concerning Risk of Eye Injury. Wear ANSI-approved safety goggles with side shields.
	Read the manual before set-up and/or use.
	WARNING marking concerning Risk of Fire. Do not cover Charger ventilation ducts. Charge on fireproof surface only.
	WARNING marking concerning Risk of Explosion. Do not puncture, short, or open battery packs and do not charge damaged battery packs.

## SPECIFICATIONS

Battery Type	Hercules 20V Li-Ion
Charger Type	Hercules 20V Li-Ion
No Load Speed	n <sub>0</sub> : 0-3600/min
Speed	0-1800 RPM 0-2700 RPM 0-3600 RPM
Impact Rate	0-1200 IPM 0-3400 IPM 0-4400 IPM
Max Torque	2200 in-lb
Chuck Size	1/4" Hex Collet

## Warning Symbols and Definitions

**⚠️** This is the safety alert symbol. It is used to alert you to potential personal injury hazards. Obey all safety messages that follow this symbol to avoid possible injury or death.

**⚠️ DANGER** Indicates a hazardous situation which, if not avoided, will result in death or serious injury.

**⚠️ WARNING** Indicates a hazardous situation which, if not avoided, could result in death or serious injury.

**⚠️ CAUTION** Indicates a hazardous situation which, if not avoided, could result in minor or moderate injury.

**NOTICE** Addresses practices not related to personal injury.

## SETUP—BEFORE USE



Read the **ENTIRE IMPORTANT SAFETY INFORMATION** section at the beginning of this manual including all text under subheadings therein before set up or use of this product.

### Functional Description

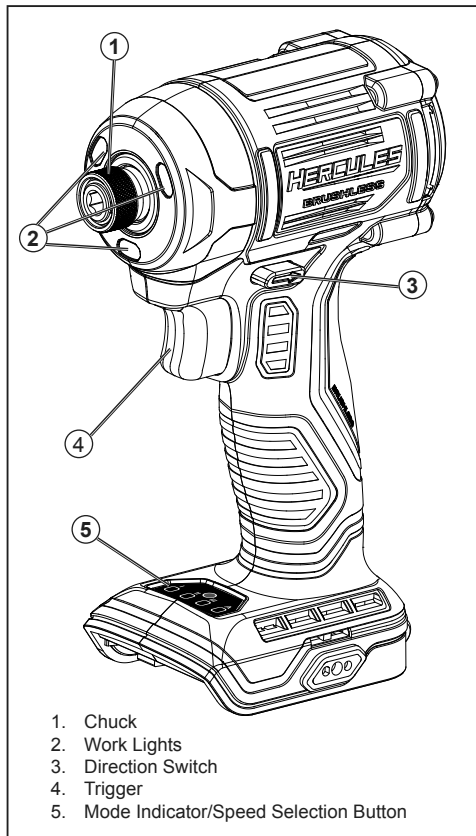

## OPERATION



Read the **ENTIRE IMPORTANT SAFETY INFORMATION** section at the beginning of this manual including all text under subheadings therein before set up or use of this product.

### Tool Set Up

#### **WARNING**

**TO PREVENT SERIOUS INJURY FROM ACCIDENTAL OPERATION:**

**Make sure that the Trigger is locked and Battery Pack is removed before performing any procedure in this section.**

#### Charging Battery Pack

Charge battery after unpacking and before using this tool. Follow instructions included with battery charger.

#### Attaching Belt Clip, Bit Holder, and Lanyard

1. Attach Belt Clip to either side of the tool using supplied Screw.
2. Attach Bit Holder to the other side using supplied Screw.

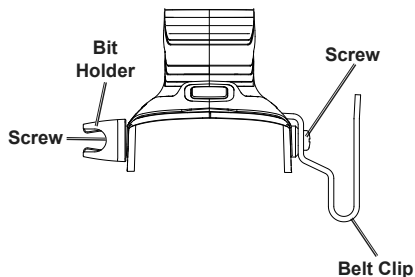

3. Attach Lanyard (sold separately) to the Lanyard Loop on the Handle.

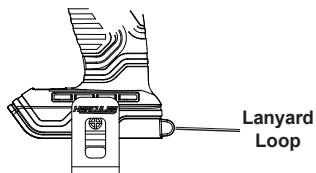

## Bit Installation

**CAUTION!** Only use 1/4" hex bits designed for impact use. Verify bit fits the Hex Chuck precisely before use.

1. Insert an appropriate impact-rated accessory (sold separately) into the hex drive Chuck. Pull on bit to ensure it is secure.
2. To remove, pull Collar forward, remove bit from Chuck and then release Collar.

## Direction Switch

**Forward:** Push Switch in on right side (arrow pointing forward) for clockwise rotation.

**Reverse:** Push Switch in on left side (arrow pointing backward) for counter-clockwise rotation.

**Trigger Lock:** Push Switch to the center to lock the Trigger.

**CAUTION!** Set Direction Switch to center Trigger Lock position during set up, when changing bits or when tool is idle.

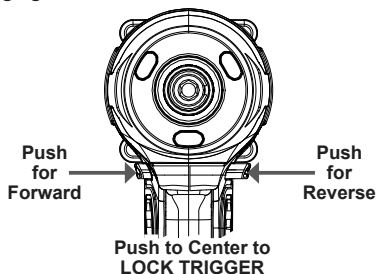

## Workpiece and Work Area Set Up

1. Designate a work area that is clean and well lit. The work area must not allow access by children or pets to prevent distraction and injury.
2. Secure loose workpieces using a vise or clamps (not included) to prevent movement while working.
3. There must not be objects, such as utility lines, nearby that will present a hazard while working.

## General Operation

1. Lock Trigger, then insert a fully charged Battery Pack, making sure that it clicks into place securely.
2. Install Bit and set Direction Switch.

**NOTICE: Do not change direction of rotation while Chuck is rotating.** Wait until Chuck has come to a complete stop before changing direction.

3. Set Mode:  
Push Speed Selection Button to cycle through 4 modes.  
**I** - 0-1800 RPM and 0-1200 IPM  
**II** - 0-2700 RPM and 0-3400 IPM  
**III** - 0-3600 RPM and 0-4400 IPM  
**A - Forward:** Tool stops within a few impacts when driving small, self-tapping metal screws.  
**A - Reverse:** Tool stops once impacting has stopped.
4. Press Trigger to start the tool. The Work Lights will turn on when Trigger is pressed and turn off when Trigger is released.
5. The tool has variable speed. To increase speed, apply more pressure to Trigger. To decrease speed, lessen pressure on Trigger.

**Note:** The amount of actual torque will vary depending on the cleanness and condition of the threads and other factors. If tightening critical components, chase threads before assembling components and check the actual torque applied to the fastener with a mechanical torque wrench (not included).

6. When finished using the tool, release Trigger and center Direction Switch to lock Trigger.
7. To prevent accidents, turn off the tool and remove its Battery Pack after use. Clean, then store the tool indoors out of children's reach.

## MAINTENANCE AND SERVICING



Procedures not specifically explained in this manual must be performed only by a qualified technician.

### **! WARNING**

**TO PREVENT SERIOUS INJURY FROM ACCIDENTAL OPERATION:**

**Make sure that the Trigger is locked and Battery Pack is removed before performing any procedure in this section.**

**TO PREVENT SERIOUS INJURY FROM TOOL FAILURE:**

**Do not use damaged equipment.**

**If abnormal noise or vibration occurs, have the problem corrected before further use.**

## *Cleaning, Maintenance, and Lubrication*

1. **BEFORE EACH USE**, inspect the general condition of the tool. Check for:
  - leaking, swollen, or cracked battery pack,
  - loose hardware,
  - misalignment or binding of moving parts,
  - cracked or broken parts,
  - any other condition that may affect its safe operation.
2. **AFTER USE**, wipe external surfaces of the tool with clean cloth.
3. **Li-ion BATTERY MUST BE RECYCLED OR DISPOSED OF PROPERLY.**  
Do not short, incinerate or open battery.
4. Disconnect battery pack and store battery pack, charger, and tool in dry, indoor area out of reach of children and away from metal objects (i.e., paperclips, coins) to prevent shorting.

## Troubleshooting

Problem	Possible Causes	Likely Solutions
Tool will not start.	<ol style="list-style-type: none"> <li>1. Battery Pack not properly connected.</li> <li>2. Battery Pack not properly charged.</li> <li>3. Battery Pack stopped working.</li> <li>4. Internal damage or wear. (Trigger, for example.)</li> </ol>	<ol style="list-style-type: none"> <li>1. Remove Battery Pack, make sure there are no obstructions, clean battery contacts on tool, reinsert the Battery Pack according to its shape (it should only fit one way), and press firmly until the Battery Pack locks in place.</li> <li>2. Make sure Charger is connected and operating properly. Give enough time for Battery Pack to recharge properly.</li> <li>3. Dispose of old Battery Pack properly or recycle. Replace Battery Pack.</li> <li>4. Have technician service tool.</li> </ol>
Tool operates slowly.	<ol style="list-style-type: none"> <li>1. Forcing tool to work too fast.</li> <li>2. Battery Pack wearing out.</li> </ol>	<ol style="list-style-type: none"> <li>1. Allow tool to work at its own rate.</li> <li>2. Dispose of old Battery Pack properly or recycle. Replace Battery Pack.</li> </ol>
Performance decreases over time.	Bit dull or damaged.	Keep bits sharp, replace as needed.
Excessive noise/rattling.	Internal damage or wear.	Have technician service tool.
Overheating.	<ol style="list-style-type: none"> <li>1. Forcing tool to work too fast.</li> <li>2. Blocked motor housing vents.</li> </ol>	<ol style="list-style-type: none"> <li>1. Allow tool to work at its own rate.</li> <li>2. Wear ANSI-approved safety goggles and NIOSH-approved dust mask/respirator while blowing dust out of motor using compressed air.</li> </ol>
 <p><b>Follow all safety precautions whenever diagnosing or servicing the tool. Disconnect Battery Pack and Charger power supply before service.</b></p>		

Record Product's Serial Number Here: \_\_\_\_\_

**Note:** If product has no serial number, record month and year of purchase instead.

**Note:** Replacement parts may be available for this item.

Visit [harborfreight.com/parts](http://harborfreight.com/parts) for a list of in-stock parts. Reference UPC 193175469960.

**HERCULES**

## **5-YEAR LIMITED WARRANTY**

This Hercules tool is warranted to the original purchaser to be free from defects in materials and workmanship for a period of five (5) years beginning on the date of purchase. This warranty does not cover battery packs and battery chargers, which are covered under separate warranties. To obtain warranty service, visit your local Harbor Freight retail store. Warranty registration is not required. The product or part must be returned to us with proof of purchase (e.g. in-store receipt or packing slip/invoice) and may require shipment by purchaser to a service center at purchaser's expense. If our inspection verifies a covered defect in materials or workmanship during the warranty period, we will, at our option, repair or replace the defective product. We will return repaired products within a reasonable time at our expense, but if we determine that there is no defect, or that the defect resulted from causes not within the scope of our warranty, then we will return the product to you if you pay return shipping costs.

This warranty does not cover any failure or damage that we determine is due directly or indirectly to normal wear and tear, misuse, use not for the intended purpose or not in accordance with the product manual, abuse, accident, rental, modification or alteration, unauthorized repair, improper installation, neglect, lack of maintenance, or any other failure not arising from defective materials or workmanship. Fraudulent returns or claims will be denied. The repair or replacement described in this warranty shall be your sole and exclusive remedy. THIS WARRANTY IS EXCLUSIVE AND IN LIEU OF ALL OTHER EXPRESS WARRANTIES, WRITTEN OR ORAL, AND ANY IMPLIED WARRANTIES ARE DISCLAIMED TO THE EXTENT PERMITTED BY LAW AND OTHERWISE LIMITED TO THE DURATION OF THE EXPRESS WARRANTY HEREIN. HARBOR FREIGHT SHALL NOT BE LIABLE UNDER ANY CIRCUMSTANCES FOR ANY INCIDENTAL, INDIRECT, SPECIAL, CONSEQUENTIAL, OR PUNITIVE DAMAGES OR COSTS ARISING FROM THIS WARRANTY OR THE USE OF THIS PRODUCT. SOME STATES DO NOT ALLOW LIMITATIONS ON HOW LONG AN IMPLIED WARRANTY LASTS OR THE EXCLUSION OR LIMITATION OF INCIDENTAL OR CONSEQUENTIAL DAMAGES, SO THESE LIMITATIONS MAY NOT APPLY TO YOU. THIS WARRANTY GIVES YOU SPECIFIC LEGAL RIGHTS, AND YOU MAY ALSO HAVE OTHER RIGHTS WHICH VARY FROM STATE TO STATE.

The logo for Hercules, featuring the word "HERCULES" in a bold, italicized, sans-serif font. The letters are black with a white outline, and the entire word is set against a black background that tapers to a point at the bottom, resembling a stylized arrow or a wing.

**Visit our website at: <http://www.harborfreight.com>  
Email our technical support at: [productsupport@harborfreight.com](mailto:productsupport@harborfreight.com)  
For technical questions, please call 1-888-866-5797**

---

Copyright© 2022 by Harbor Freight Tools®. All rights reserved. No portion of this manual or any artwork contained herein may be reproduced in any shape or form without the express written consent of Harbor Freight Tools. Diagrams within this manual may not be drawn proportionally. Due to continuing improvements, actual product may differ slightly from the product described herein. Tools required for assembly and service may not be included.

***HERCULES***

26677 Agoura Road • Calabasas, CA 91302 • 1-888-866-5797



**Model  
HC04**

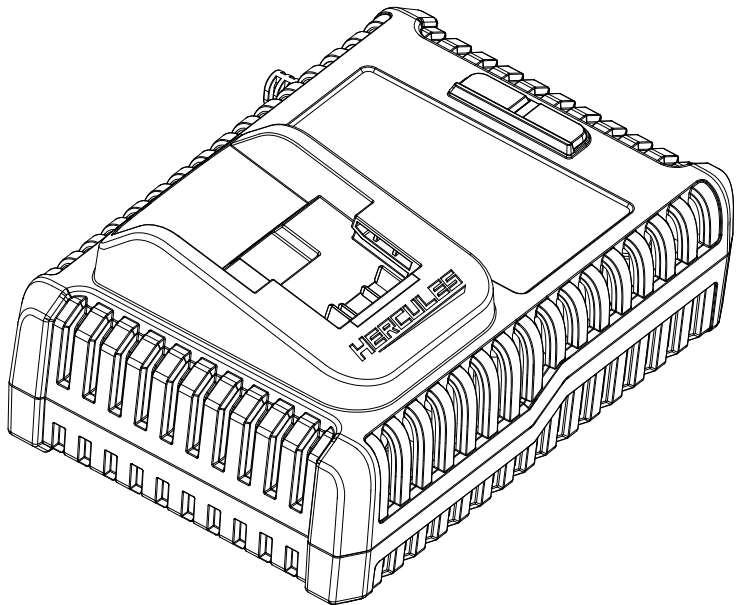

### 12V/20V Lithium-Ion Fast Charger



**⚠WARNING: To prevent serious injury, User must read and understand Owner's Manual. SAVE THIS MANUAL.**

When unpacking, make sure that the product is intact and undamaged.  
If any parts are missing or broken, please call 1-888-866-5797  
as soon as possible. Reference 56559.

# IMPORTANT SAFETY INFORMATION

## WARNING

Read all safety warnings and all instructions.

Failure to follow the warnings and instructions may result in electric shock, fire and/or serious injury. **Save all warnings and instructions for future reference.** The warnings, precautions, and instructions discussed in this instruction manual cannot cover all possible conditions and situations that may occur. It must be understood by the operator that common sense and caution are factors which cannot be built into this product, but must be supplied by the operator.

-  The battery Charger gets hot during use. The Charger's heat can build up to unsafe levels and create a fire hazard if it does not receive adequate ventilation, due to an electrical fault, or if it is used in a hot environment. Do not place the Charger on a flammable surface. Do not obstruct any vents on the Charger. **Epecially avoid placing the Charger on carpets and rugs; they are not only flammable, but they also obstruct vents under the Charger.** Place the Charger on a stable, solid, nonflammable surface (such as a stable metal workbench or concrete floor) at least 1 foot away from all flammable objects, such as drapes or walls. Keep a fire extinguisher and a smoke detector in the area. Frequently monitor the Charger and Battery Pack while charging.
- Charge only designated battery packs; others may overheat, leak, or burst.**
- Follow charging instructions.**
- Do not insert damaged battery pack.**
- Check frequently while charging.**
- Wear ANSI-approved safety goggles during use.**
- Use chargers only with specifically designated battery packs.** Use of any other battery packs may create a risk of injury and fire.
- When battery pack is not in use, keep it away from other metal objects, like paper clips, coins, keys, nails, screws or other small metal objects, that can make a connection from one terminal to another.** Shorting the battery pack terminals together may cause burns or a fire.
- Under abusive conditions, liquid may be ejected from the battery pack; avoid contact. If contact accidentally occurs, flush with water. If liquid contacts eyes, additionally seek medical help.** Liquid ejected from the battery pack may cause irritation or burns.

- Do not expose to rain or wet conditions. Indoor use only.
- Inspect before every use; do not use if parts are loose or damaged.
- Use as intended only.
- Unplug after use and before service, cleaning or storage.
- Maintain labels and nameplates on the Charger. These carry important safety information. If unreadable or missing, contact Harbor Freight Tools for a replacement.
- This product is not a toy. Keep it out of reach of children.
- People with pacemakers should consult their physician(s) before use. Electromagnetic fields in close proximity to heart pacemaker could cause pacemaker interference or pacemaker failure. In addition, people with pacemakers should properly maintain and inspect to avoid electrical shock.

## Lithium Battery Safety Warnings



**LITHIUM BATTERIES  
STORE A LARGE AMOUNT  
OF ENERGY AND WILL**

**VENT FIRE OR EXPLODE IF MISTREATED:**

- Keep Battery Pack dry.
- DO NOT DO ANY OF THE FOLLOWING TO THE BATTERY PACK:**
  - Open,
  - Drop,
  - Short-circuit,
  - Puncture,
  - Incinerate, or
  - Expose to temperatures greater than 140°F.
- Charge Battery Pack only according to instructions.
- Inspect Battery Pack before every use; do not use or charge if damaged.



**SAVE THESE  
INSTRUCTIONS**

## Grounding

### **⚠️ WARNING**



**TO PREVENT ELECTRIC SHOCK AND DEATH FROM INCORRECT GROUNDING:** Check with a qualified electrician if you are in doubt as to whether the outlet is properly grounded. Do not modify the power cord plug provided with the charger. Do not use the charger if the power cord or plug is damaged. If damaged, have it repaired by a service facility before use. If the plug will not fit the outlet, have a proper outlet installed by a qualified electrician.

### Extension Cords

Extension cords must not be used with this Charger.

### Warning Symbols and Definitions



This is the safety alert symbol. It is used to alert you to potential personal injury hazards. Obey all safety messages that follow this symbol to avoid possible injury or death.

### **⚠️ DANGER**

Indicates a hazardous situation which, if not avoided, will result in death or serious injury.

### **⚠️ WARNING**

Indicates a hazardous situation which, if not avoided, could result in death or serious injury.

### **⚠️ CAUTION**

Indicates a hazardous situation which, if not avoided, could result in minor or moderate injury.

### **NOTICE**

Addresses practices not related to personal injury.

## Symbology

<b>V</b>	Volts
	Direct Current
	Alternating Current
<b>A</b>	Amperes
	WARNING marking concerning Risk of Eye Injury. Wear ANSI-approved safety goggles with side shields.
	Read the manual before set-up and/or use.
	WARNING marking concerning Risk of Fire. Do not cover Charger ventilation ducts. Charge on fireproof surface only.
	WARNING marking concerning Risk of Explosion. Do not puncture, short, or open battery packs and do not charge damaged battery packs.
	WARNING marking concerning Risk of Electric Shock. Properly connect Charger's power cord to appropriate outlet.

## FUNCTIONAL DESCRIPTION

## SPECIFICATIONS

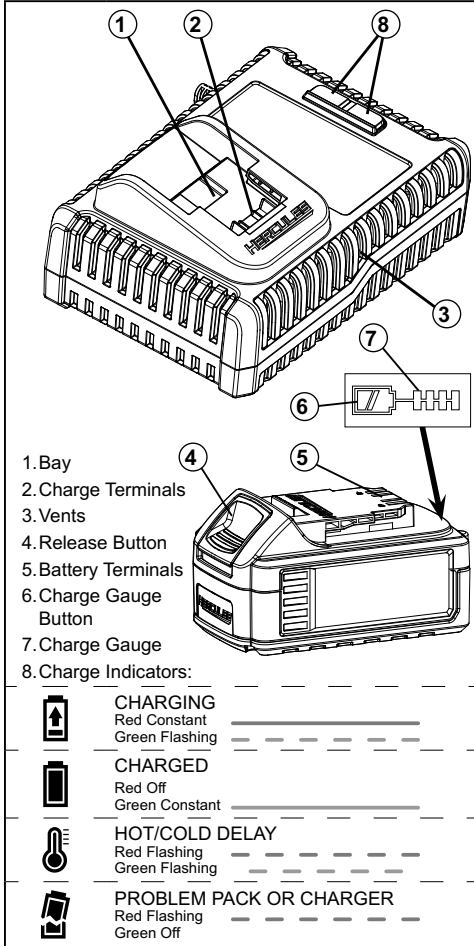

Input Rating	120VAC / 60Hz / 1.5A
Output	12 or 20 VDC / 4.0A
Battery Type	Li-ion

## BATTERY PACK OPERATION

### Charge Gauge

Press the Charge Gauge Button on the Battery to check its remaining run time.

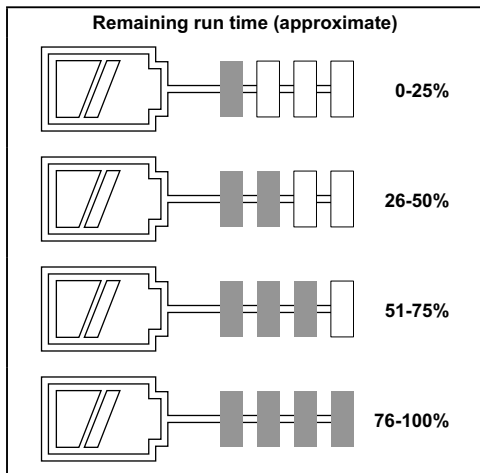

**Note:** If the Charge Gauge does not display when the Charge Gauge Button is pressed, charge the Battery Pack.

The Battery Pack will shut itself off once it is fully discharged. Charge the Battery Pack when this happens.

### Cold Weather

To warm up a Battery Pack that is very cold, operate the tool slowly or in a light application for a few minutes until the Battery Pack warms-up.

### Battery Storage

#### **⚠ WARNING**

To prevent serious injury, do not do any of the following to the Battery Pack:

- Open,
- Drop,
- Short-circuit,
- Puncture,
- Incinerate, or
- Expose to temperatures greater than 140°F.

1. Store batteries in a dry, indoor area at room temperature out of reach of children and away from metal objects (i.e., paperclips, coins) to prevent shorting.

**NOTICE:** Battery may be damaged if stored at high temperatures (over 120° F).

2. Recharge the Battery Pack at least once a year.

## CHARGER OPERATION







Read the **ENTIRE IMPORTANT SAFETY INFORMATION** section at the beginning of this manual including all text under subheadings therein before set up or use of this product.

### When to Charge

1. Charge the Battery Pack when convenient.
2. The Battery Pack does not need to be completely discharged before charging. It will not develop a "memory" if charged while still partially full.
3. To help protect the Battery Pack, it must be charged when the charge level is near empty. If a lithium-ion battery is allowed to discharge completely, it can be ruined.

### Charging

	<b>CHARGING</b> Red Constant _____ Green Flashing - - - - -
	<b>CHARGED</b> Red Off _____ Green Constant _____
	<b>HOT/COLD DELAY</b> Red Flashing - - - - - Green Flashing - - - - -
	<b>PROBLEM PACK OR CHARGER</b> Red Flashing - - - - - Green Off _____

**Figure A: Charge Indicators**

1. Place the Battery Pack on a dry fireproof surface in a room where the temperature is between 50–104° F.

**Note:** If recharging a newly spent Battery Pack, allow it to cool completely before charging.

2. Examine the Battery Pack. It must be undamaged, and a 12 or 20 volt, Lithium-ion type Battery Pack. **Do not charge a cracked, open, or leaking Battery Pack, or charge a non-recommended type of Battery Pack.**
3. The Battery Pack's terminals are designed to fit this Charger specifically. If the Battery Pack does not fit the Charger properly, do not try to insert it. **Do not force a Battery Pack into the Charger.**
4. Plug the Charger into a grounded, 120VAC, 60Hz receptacle.
5. Slide the Battery Pack onto the Charger.

- A fully discharged 2.5 Ah Battery Pack will take about 60 minutes to fully charge.
- A fully discharged 5.0 Ah (XP) Battery Pack will take about 90 minutes to fully charge.

**Note:** If the Battery Pack is hot or cold, the Charge Indicators may both flash, indicating that the Charger is waiting for the temperature to normalize before Charging. Charging will start automatically once the Battery Pack reaches the correct temperature.

6. While charging, the Battery Pack and Charger may become warm to the touch. This is normal, and does not indicate a problem.
7. The red LED will light constantly and the green LED will flash when the Battery Pack is charging. The green LED will light constantly and the red LED will turn off when the battery is charged. **Unplug the Charger and disconnect it from the Battery Pack when finished.**
8. Allow the Battery Pack to cool completely before using it.
9. Press the Release Button to release Battery Pack from the Charger.

## CHARGER MAINTENANCE AND SERVICING



Procedures not specifically explained in this manual must be performed only by a qualified technician.

### **⚠ WARNING**

#### **TO PREVENT SERIOUS INJURY FROM ACCIDENTAL OPERATION:**

**Remove the Battery Pack and unplug the charger before performing any inspection, maintenance, or cleaning procedures.**

**TO PREVENT SERIOUS INJURY FROM TOOL FAILURE: Do not use damaged equipment. If damage is noted, have the problem corrected before further use.**

- BEFORE EACH USE**, inspect the general condition of the charger. Check for:
  - loose hardware,
  - misalignment or binding of moving parts,
  - cracked or broken parts,
  - damaged electrical wiring, and
  - any other condition that may affect its safe operation.
- AFTER USE**, wipe external surfaces of the charger with clean cloth.
- Li-Ion BATTERY MUST BE RECYCLED OR DISPOSED OF PROPERLY.  
Do not short, incinerate or open battery.
- Disconnect Battery Pack and store Charger and any Battery Packs in a dry, indoor area at room temperature out of reach of children and away from metal objects (i.e., paperclips, coins) to prevent shorting.

**WARNING! TO PREVENT SERIOUS INJURY AND DEATH FROM ELECTRIC SHOCK: Do not open Charger. Do not service internal parts.**

This device complies with Part 15 of the FCC Rules. Operation is subject to the following two conditions: (1) this device may not cause harmful interference, and (2) this device must accept any interference received, including interference that may cause undesired operation.

Record Product's Serial Number Here: \_\_\_\_\_

**Note:** If product has no serial number, record month and year of purchase instead.

Replacement parts are not available.

**Note:** Some parts are listed and shown for illustration purposes only. Specify UPC 792363565592 when ordering parts.

## 3-YEAR LIMITED WARRANTY

This Hercules tool is warranted to the original purchaser to be free from defects in materials and workmanship for a period of three (3) years beginning on the date of purchase. To obtain warranty service, visit your local Harbor Freight retail store. Warranty registration is not required. The product or part must be returned to us with proof of purchase (e.g. in-store receipt or packing slip/invoice) and may require shipment by purchaser to a service center at purchaser's expense. If our inspection verifies a covered defect in materials or workmanship during the warranty period, we will, at our option, repair or replace the defective product. We will return repaired products within a reasonable time at our expense, but if we determine that there is no defect, or that the defect resulted from causes not within the scope of our warranty, then we will return the product to you if you pay return shipping costs.

This warranty does not cover any failure or damage that we determine is due directly or indirectly to normal wear and tear, misuse, use not for the intended purpose or not in accordance with the product manual, abuse, accident, rental, modification or alteration, unauthorized repair, improper installation, neglect, lack of maintenance, or any other failure not arising from defective materials or workmanship. Fraudulent returns or claims will be denied. The repair or replacement described in this warranty shall be your sole and exclusive remedy. THIS WARRANTY IS EXCLUSIVE AND IN LIEU OF ALL OTHER EXPRESS WARRANTIES, WRITTEN OR ORAL, AND ANY IMPLIED WARRANTIES ARE DISCLAIMED TO THE EXTENT PERMITTED BY LAW AND OTHERWISE LIMITED TO THE DURATION OF THE EXPRESS WARRANTY HEREIN. HARBOR FREIGHT SHALL NOT BE LIABLE UNDER ANY CIRCUMSTANCES FOR ANY INCIDENTAL, INDIRECT, SPECIAL, CONSEQUENTIAL, OR PUNITIVE DAMAGES OR COSTS ARISING FROM THIS WARRANTY OR THE USE OF THIS PRODUCT. SOME STATES DO NOT ALLOW LIMITATIONS ON HOW LONG AN IMPLIED WARRANTY LASTS OR THE EXCLUSION OR LIMITATION OF INCIDENTAL OR CONSEQUENTIAL DAMAGES, SO THESE LIMITATIONS MAY NOT APPLY TO YOU. THIS WARRANTY GIVES YOU SPECIFIC LEGAL RIGHTS, AND YOU MAY ALSO HAVE OTHER RIGHTS WHICH VARY FROM STATE TO STATE.

Visit our website at: <http://www.harborfreight.com>

Email our technical support at: [productsupport@harborfreight.com](mailto:productsupport@harborfreight.com)

For technical questions, please call 1-888-866-5797

---

Copyright© 2019 by Harbor Freight Tools®. All rights reserved. No portion of this manual or any artwork contained herein may be reproduced in any shape or form without the express written consent of Harbor Freight Tools. Diagrams within this manual may not be drawn proportionally. Due to continuing improvements, actual product may differ slightly from the product described herein. Tools required for assembly and service may not be included.

# **HERCULES®**

26677 Agoura Road • Calabasas, CA 91302 • 1-888-866-5797