

# Owner's Manual & Safety Instructions

**Save This Manual** Keep this manual for the safety warnings and precautions, assembly, operating, inspection, maintenance and cleaning procedures. Write the product's Date Code in the back of the manual near the assembly diagram (or month and year of purchase if product has no number). Keep this manual and the receipt in a safe and dry place for future reference.

25i

# **ATLAS** **BRUSHLESS** **DUAL PORT BACKPACK BLOWER** **80V** **LITHIUM**



Visit our website at: <https://www.harborfreight.com>  
Email our technical support at: [productsupport@harborfreight.com](mailto:productsupport@harborfreight.com)

70822

When unpacking, make sure that the product is intact and undamaged. If any parts are missing or broken, please call 1-800-444-3353 as soon as possible.

## **⚠️ WARNING**

Read this material before using this product. Failure to do so can result in serious injury. **SAVE THIS MANUAL.**

Copyright© 2025 by Harbor Freight Tools®. All rights reserved.  
No portion of this manual or any artwork contained herein may be reproduced in any shape or form without the express written consent of Harbor Freight Tools. Diagrams within this manual may not be drawn proportionally. Due to continuing improvements, actual product may differ slightly from the product described herein. Tools required for assembly and service may not be included.

# Table of Contents

Safety .....	2	Maintenance .....	12
Specifications .....	6	Parts List and Diagram .....	14
Setup .....	7	Warranty .....	16
Operation.....	10		



SAFETY

SETUP

OPERATION

MAINTENANCE

## WARNING SYMBOLS AND DEFINITIONS

	This is the safety alert symbol. It is used to alert you to potential personal injury hazards. Obey all safety messages that follow this symbol to avoid possible injury or death.
	Indicates a hazardous situation which, if not avoided, will result in death or serious injury.
	Indicates a hazardous situation which, if not avoided, could result in death or serious injury.
	Indicates a hazardous situation which, if not avoided, could result in minor or moderate injury.
	Addresses practices not related to personal injury.

## IMPORTANT SAFETY INFORMATION

### General Tool Safety Warnings

#### WARNING

Read all safety warnings, instructions, illustrations and specifications provided with this tool. Failure to follow all instructions listed below may result in electric shock, fire and/or serious injury.

Save all warnings and instructions for future reference.

The term "tool" in the warnings refers to your mains-operated (corded) tool or battery-operated (cordless) tool.

1. **Work area safety**
  - a. **Keep work area clean and well lit.**  
*Cluttered or dark areas invite accidents.*
  - b. **Do not operate tools in explosive atmospheres, such as in the presence of flammable liquids, gases or dust.** *Tools create sparks which may ignite the dust or fumes.*
  - c. **Keep children and bystanders away while operating a tool.** *Distractions can cause you to lose control.*

## 2. Electrical safety

- a. **Tool plugs must match the outlet. Never modify the plug in any way. Do not use any adapter plugs with earthed (grounded) tools.** *Unmodified plugs and matching outlets will reduce risk of electric shock.*
- b. **Avoid body contact with earthed or grounded surfaces, such as pipes, radiators, ranges and refrigerators.** *There is an increased risk of electric shock if your body is earthed or grounded.*
- c. **Do not expose tools to rain or wet conditions.** *Water entering a tool will increase the risk of electric shock.*
- d. **Do not abuse the cord. Never use the cord for carrying, pulling or unplugging the tool. Keep cord away from heat, oil, sharp edges or moving parts. Damaged or entangled cords increase the risk of electric shock.**
- e. **When operating a tool outdoors, use an extension cord suitable for outdoor use.** *Use of a cord suitable for outdoor use reduces the risk of electric shock.*
- f. **If operating a tool in a damp location is unavoidable, use a ground fault circuit interrupter (GFCI) protected supply.** *Use of a GFCI reduces the risk of electric shock.*

## 3. Personal safety

- a. **Stay alert, watch what you are doing and use common sense when operating a tool. Do not use a tool while you are tired or under the influence of drugs, alcohol or medication.** *A moment of inattention while operating tools may result in serious personal injury.*
- b. **Use personal protective equipment. Always wear eye protection.** *Protective equipment such as dust mask, non-skid safety shoes, hard hat, or hearing protection used for appropriate conditions will reduce personal injuries.*
- c. **Prevent unintentional starting. Ensure the switch is in the off-position before connecting to power source and/or battery pack, picking up or carrying the tool.** *Carrying tools with your finger on the switch or energizing tools that have the switch on invites accidents.*
- d. **Remove any adjusting key or wrench before turning the tool on.** *A wrench or a key left attached to a rotating part of the tool may result in personal injury.*
- e. **Do not overreach. Keep proper footing and balance at all times.** *This enables better control of the tool in unexpected situations.*
- f. **Dress properly. Do not wear loose clothing or jewelry. Keep your hair, clothing and gloves away from moving parts.** *Loose clothes, jewelry or long hair can be caught in moving parts.*

- g. **If devices are provided for the connection of dust extraction and collection facilities, ensure these are connected and properly used.** *Use of dust collection can reduce dust-related hazards.*
- h. **Do not let familiarity gained from frequent use of tools allow you to become complacent and ignore tool safety principles.** *A careless action can cause severe injury within a fraction of a second.*
- i. Only use safety equipment that has been approved by an appropriate standards agency. Unapproved safety equipment may not provide adequate protection. Eye protection must be ANSI-approved and breathing protection must be NIOSH-approved for the specific hazards in the work area.
- j. Do not leave the tool unattended when the Battery Pack is connected. Turn off the tool, and remove the Battery Pack before leaving.
- k. This product is not a toy. Keep it out of reach of children.
- l. People with pacemakers should consult their physician(s) before use. Electromagnetic fields in close proximity to heart pacemaker could cause pacemaker interference or pacemaker failure.
- m. The warnings, precautions, and instructions discussed in this instruction manual cannot cover all possible conditions and situations that may occur. It must be understood by the operator that common sense and caution are factors which cannot be built into this product, but must be supplied by the operator.

## 4. Tool use and care

- a. **Do not force the tool. Use the correct tool for your application.** *The correct tool will do the job better and safer at the rate for which it was designed.*
- b. **Do not use the tool if the switch does not turn it on and off.** *Any tool that cannot be controlled with the switch is dangerous and must be repaired.*
- c. **Disconnect the plug from the power source and/or remove the battery pack, if detachable, from the tool before making any adjustments, changing accessories, or storing tools.** *Such preventive safety measures reduce the risk of starting the tool accidentally.*
- d. **Store idle tools out of the reach of children and do not allow persons unfamiliar with the tool or these instructions to operate the tool.** *Tools are dangerous in the hands of untrained users.*

- e. **Maintain tools and accessories.** Check for misalignment or binding of moving parts, breakage of parts and any other condition that may affect the tool's operation. If damaged, have the tool repaired before use. *Many accidents are caused by poorly maintained tools.*
  - f. **Keep cutting tools sharp and clean.** *Properly maintained cutting tools with sharp cutting edges are less likely to bind and are easier to control.*
  - g. **Use the tool, accessories and tool bits etc. in accordance with these instructions, taking into account the working conditions and the work to be performed.** *Use of the tool for operations different from those intended could result in a hazardous situation.*
  - h. **Keep handles and grasping surfaces dry, clean and free from oil and grease.** *Slippery handles and grasping surfaces do not allow for safe handling and control of the tool in unexpected situations.*
5. **Service**
- a. **Have your tool serviced by a qualified repair person using only identical replacement parts.** *This will ensure that the safety of the tool is maintained.*
  - b. **Never service damaged BATTERY packs.** *Service of BATTERY packs should only be performed by the manufacturer or authorized service providers.*
  - c. **Maintain labels and nameplates on the tool.** *These carry important safety information. If unreadable or missing, contact Harbor Freight Tools for a replacement.*
6. **Garden blower safety warnings**
- a. **Do not use the garden blower in bad weather conditions, especially when there is a risk of lightning.** *This decreases the risk of being struck by lightning.*
  - b. **Wear eye protection and ear protection.** *Adequate protective equipment will reduce the risk of personal injury.*
  - c. **While operating the garden blower, always wear non-slip and protective footwear. Do not operate the garden blower when barefoot or wearing open sandals.** *This reduces the risk of injury to the feet.*
  - d. **Do not wear loose fitting clothing or articles such as scarves, strings, chains, ties, etc., that could get drawn into the air inlets. Tie back or cover long hair to make sure it does not get drawn into the air inlets. If any of these items are drawn into the air inlets, it can increase the risk of personal injury.**
  - e. **Keep bystanders away while operating the garden blower** *Thrown debris can increase the risk of personal injury.*
- f. **Never point the blower nozzle in the direction of people or pets or in the direction of windows.** *Use extra caution when blowing debris near solid objects, such as trees, automobiles and walls that can cause debris to ricochet. Thrown objects can damage properly and increase the risk of personal injury.*
  - g. **Do not use the garden blower to blow anything that is burning or smoking, such as cigarettes, matches or hot ashes.** *These ignition sources may increase the risk of fire.*
  - h. **Do not touch the fan while still in motion. Turn off the garden blower, wait until the fan stops and unplug the garden blower, before removing any part that may give access to the fan.** *This reduces the risk of injury from moving parts.*
  - i. **When clearing jammed material or servicing the garden blower, make sure the power switch is off and the power cord is disconnected.** *Unexpected actuation of the garden blower while cleaning Jammed material/ or servicing may increase the risk of personal injury.*
7. **Battery tool use and care**
- a. **Prevent unintentional starting.** *Ensure the switch is in the off-position before connecting to battery pack, picking up or carrying the tool. Carrying the tool with your finger on the switch or energizing tool that have the switch on invites accidents.*
  - b. **Disconnect the battery pack from the tool before making any adjustments, changing accessories, or storing tool.** *Such preventive safety measures reduce the risk of starting the tool accidentally.*
  - c. **Recharge only with the charger specified by the manufacturer.** *A charger that is suitable for one type of battery pack may create a risk of fire when used with another battery pack.*
  - d. **Use tools only with specifically designated battery packs.** *Use of any other battery packs may create a risk of injury and fire.*
  - e. **When battery pack is not in use, keep it away from other metal objects, like paper clips, coins, keys, nails, screws or other small metal objects, that can make a connection from one terminal to another.** *Shorting the battery terminals together may cause burns or a fire.*
  - f. **Under abusive conditions, liquid may be ejected from the battery; avoid contact.** *If contact accidentally occurs, flush with water. If liquid contacts eyes, additionally seek medical help. Liquid ejected from the battery may cause irritation or burns.*

- g. **Do not use a battery pack or tool that is damaged or modified.** *Damaged or modified batteries may exhibit unpredictable behavior resulting in fire, explosion or risk of injury.*
- h. **Do not expose a battery pack or tool to fire or excessive temperature.** *Exposure to fire or temperature above 140°F may cause explosion.*
- i. **Follow all charging instructions and do not charge the battery pack or tool outside of the temperature range specified in the instructions.** *Charging improperly or at temperatures outside of the specified range may damage the battery and increase the risk of fire.*
- j. **Have servicing performed by a qualified repair person using only identical replacement parts.** *This will ensure that the safety of the product is maintained.*
- k. **Do not modify or attempt to repair the tool or the battery pack except as indicated in the instructions for use and care.**

- l.  The battery Charger gets hot during use. The Charger's heat can build up to unsafe levels and create a fire hazard if it does not receive adequate ventilation, due to an electrical fault, or if it is used in a hot environment. Do not place the Charger on a flammable surface. Do not obstruct any vents on the Charger. **Especially avoid placing the Charger on carpets and rugs; they are not only flammable, but they also obstruct vents under the Charger.** Place the Charger on a stable, solid, nonflammable surface (such as a stable metal workbench or concrete floor) at least 1 foot away from all flammable objects, such as drapes or walls. Keep a fire extinguisher and a smoke detector in the area. Frequently monitor the Charger and Battery Pack while charging.

#### 8. Lithium Battery Safety Warnings



**LITHIUM BATTERIES STORE A LARGE AMOUNT OF ENERGY AND WILL VENT FIRE OR EXPLODE IF MISTREATED:**

- a. **Keep Battery Pack dry.**
- B. **DO NOT DO ANY OF THE FOLLOWING TO THE BATTERY PACK:**
  - **Open,**
  - **Drop,**
  - **Short-circuit,**
  - **Puncture,**
  - **Incinerate, or**
  - **Expose to temperatures greater than 140°F.**
- c. Charge Battery Pack only according to its Charger's instructions.
- d. Inspect Battery Pack before every use; do not use or charge if damaged.

## Grounding

### WARNING



**TO PREVENT ELECTRIC SHOCK AND DEATH FROM INCORRECT GROUNDING:**







Check with a qualified electrician if you are in doubt as to whether the outlet is properly grounded. Do not modify the power cord plug provided with the charger. Do not use the charger if the power cord or plug is damaged. If damaged, have it repaired by a service facility before use. If the plug will not fit the outlet, have a proper outlet installed by a qualified electrician.

## Extension Cords

**Note:** Extension cords must not be used with this item's Charger.

# Symbology

SAFETY

<b>V</b>	Volts		WARNING marking concerning Risk of Fire. Do not cover Charger ventilation ducts. Charge on fireproof surface only.
	Direct Current		WARNING marking concerning Risk of Electric Shock. Properly connect Charger's power cord to appropriate outlet.
<b>A</b>	Amperes		WARNING marking concerning Risk of Explosion. Do not puncture, short, or open battery packs and do not charge damaged battery packs.
n <sub>0</sub> xxxx/min.	No Load Revolutions per Minute (RPM)		WARNING marking concerning Risk of Eye Injury. Wear ANSI-approved safety goggles with side shields.
	Read the manual before set-up and/or use.		WARNING marking concerning Risk of Hearing Loss. Wear hearing protection.

SETUP

## Specifications

Electrical Rating	72V DC, 80V Max
Battery Type	Atlas 40/80V Li-Ion
Charger Type	Atlas 40/80V Li-ion
Sound Rating	70.3 dBA

**For household use only.**

OPERATION

MAINTENANCE

## Setup - Before Use:



Read the **ENTIRE IMPORTANT SAFETY INFORMATION** section at the beginning of this manual including all text under subheadings therein before set up or use of this product.

**Note:** For additional information regarding the parts listed in the following pages, refer to Parts List and Diagram on page 15.

## Assembly

### Attaching Handle

1. Slide Handle onto Upper Tube.

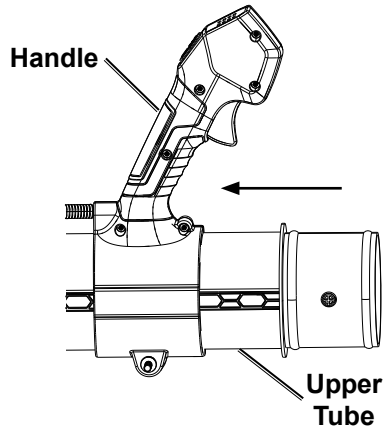

2. Secure Handle to Upper Tube with Handle Bolt and Handle Knob.

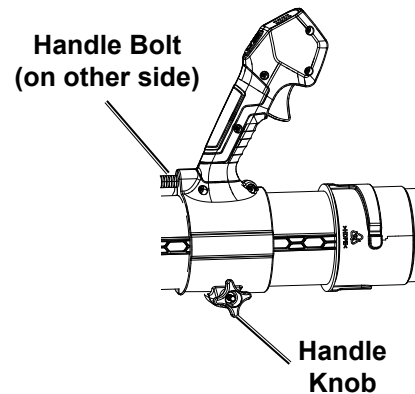

### Attaching Flex Tube

1. Loosen Hose Clamps and install them over ends of Flex Tube.

2. Slide Flex Tube over Upper Tube.

3. Slide other end over Elbow, and tighten Hose Clamp Screws.

4. Secure Control Cable to Mounting Clip.

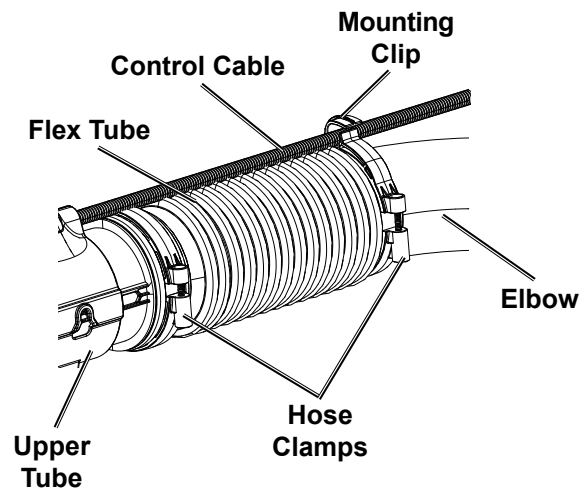

## Attaching Blower Tube and Nozzle

1. Slide Blower Tube over Upper Tube and line up Slot with Tab, then rotate Blower Tube clockwise until Tab is securely locked into Slot.

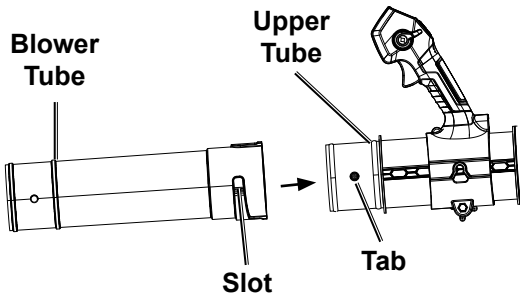

2. Slide remaining Blower Tube over end of Blower Tube, as needed, and line up Slot with Tab, then rotate Blower Tube clockwise until Tab is securely locked into Slot.

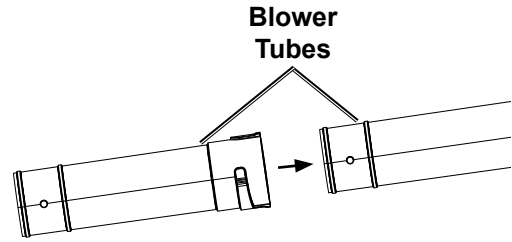

3. Slide Nozzle over Blower Tube and line up Slot with Tab, then rotate Blower Tube clockwise until Tab is securely locked into Slot.

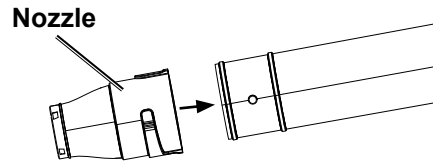

## Charging

Charge batteries before using this tool. Follow instructions included with battery charger (sold separately).

# Functions

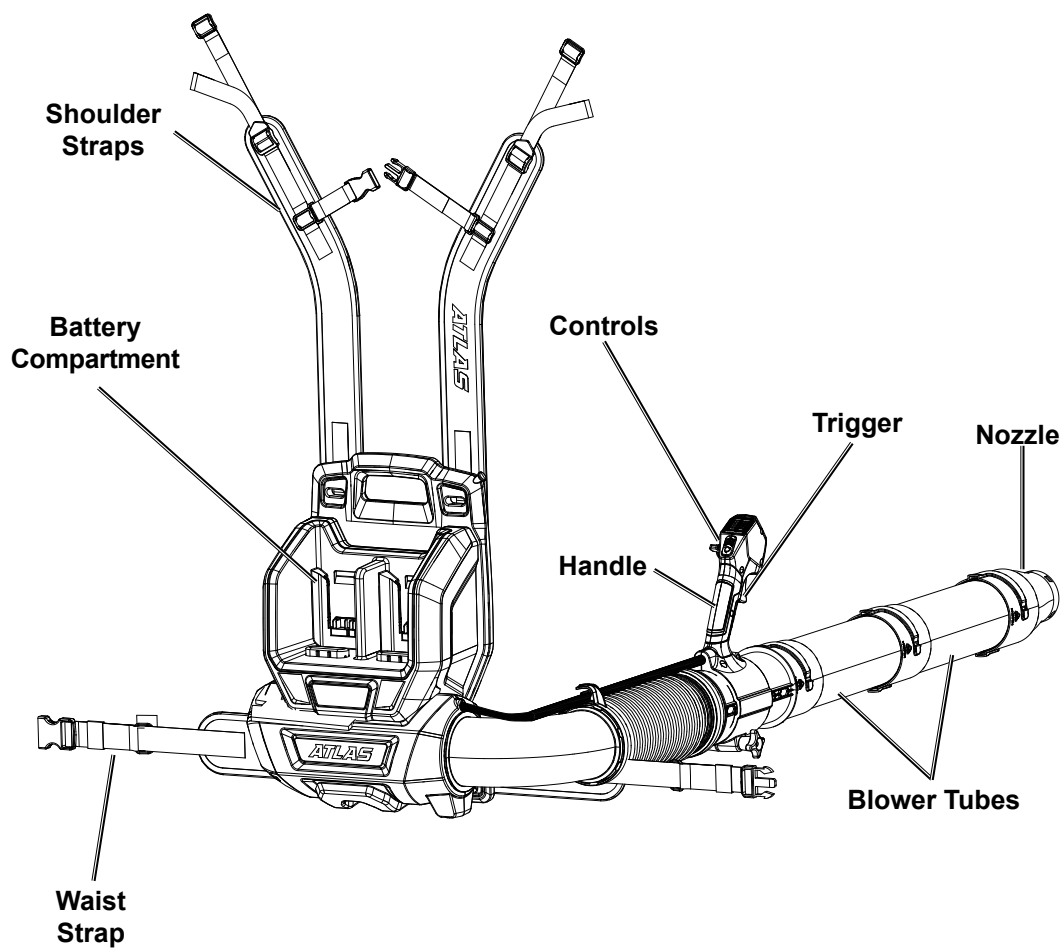

SAFETY

SETUP

OPERATION

MAINTENANCE

## Operating Instructions



Read the **ENTIRE IMPORTANT SAFETY INFORMATION** section at the beginning of this manual including all text under subheadings therein before set up or use of this product.

### **WARNING**

**TO PREVENT SERIOUS INJURY FROM FLYING DEBRIS:**

Wear long pants, long sleeves and protective footwear. Wear ANSI-approved safety goggles, dust mask, hearing protectors, and gloves.

## Installing and Removing Battery Packs

1. Make sure the Trigger is in the OFF position.
2. To install: Slide Battery Packs into Battery Compartment until they click into place.
3. To remove: Press Battery Packs' Release Buttons and pull Battery Packs out of slot.

# General Instructions for Use

## **⚠️WARNING**

### **TO AVOID SERIOUS INJURY AND PROPERTY DAMAGE:**

Inspect the area before using the Blower. Remove all hard objects from work area. Do not blow debris in the direction of people, animals or property.

**CAUTION! TO PREVENT INJURY:** Do not wear multiple harnesses or anything that would interfere with removal of the harness.

**CAUTION! TO PREVENT INJURY:** Do not stand on ladder or unstable support.

1. Strap the Blower to your back.
  - a. Put your arms through the Shoulder Straps so the pads rest on your shoulders.
  - b. Pull Chest Straps across chest and buckle together to secure.
  - c. Adjust Shoulder and Chest Straps as needed.
  - d. Pull Waist Strap around waist and buckle together to secure, adjust Waist Strap as needed.

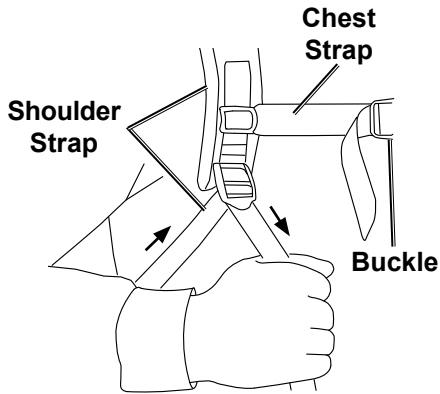

2. Loosen Handle Knob and adjust Handle position as needed. Tighten Handle Knob.

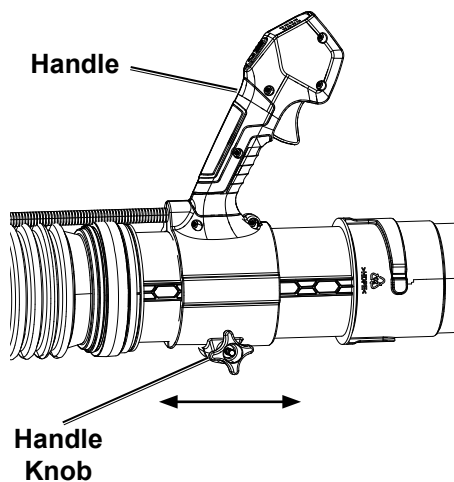

**Note:** Rake or sweep to loosen debris if necessary.

3. Hold Blower with the Nozzle close to the ground.
4. Press Trigger or push Trigger Lock forward to start the Blower.
5. Adjust the position of the Trigger or Trigger Lock to adjust the speed of the Blower.
6. Press and hold Turbo Button to temporarily increase air speed. Release Button when done.
7. Sweep from side to side.
8. Release Trigger or rotate Trigger Lock backward to turn Blower off.

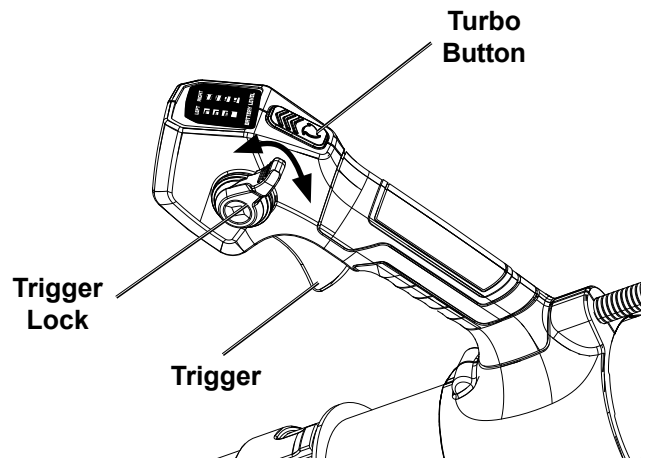

9. When finished, to prevent accidents:
  - Remove battery packs.
  - Wipe external surfaces of the appliance with clean cloth. Store in an indoor dry area out of reach of children.

## User-Maintenance and Storage



Procedures not specifically explained in this manual must be performed only by a qualified technician.

### **WARNING**

**TO PREVENT SERIOUS INJURY FROM ACCIDENTAL OPERATION:**  
Make sure that the Trigger is in the off-position and remove its Battery Pack before performing any procedure in this section.

**TO PREVENT SERIOUS INJURY FROM APPLIANCE FAILURE:**  
Do not use damaged equipment. If abnormal noise or vibration occurs, have the problem corrected before further use.

## Cleaning, Maintenance, and Lubrication

- BEFORE EACH USE**, inspect the general condition of the appliance. Check for:
  - leaking, swollen, or cracked battery pack,
  - loose hardware,
  - misalignment or binding of moving parts,
  - cracked or broken parts,
  - damaged electrical wiring, and
  - any other condition that may affect its safe operation.
- AFTER USE**, wipe external surfaces of the appliance with clean cloth.
- Li-Ion BATTERY MUST BE RECYCLED OR DISPOSED OF PROPERLY.  
Do not short, incinerate or open battery.
- All parts are permanently lubricated.  
Do not use additional lubrication.
- Disconnect battery pack and store battery pack, charger, and tool in dry, indoor area out of reach of children and away from metal objects (i.e., paperclips, coins) to prevent shorting.

## Ambient Temperate Range

Tool Operation and Storage	32°F (0°C) - 113°F (45°C)
----------------------------	---------------------------

# Troubleshooting

Problem	Possible Causes	Likely Solutions
Tool will not start.	<ol style="list-style-type: none"> <li>1. Battery Packw not properly connected.</li> <li>2. Battery Pack not properly charged.</li> <li>3. Battery Pack burnt-out.</li> <li>4. Internal damage or wear. (Trigger, for example.)</li> </ol>	<ol style="list-style-type: none"> <li>1. Remove Battery Pack, make sure there are no obstructions, reinsert the Battery Pack according to its shape (it should only fit one way), and press firmly until the Battery Pack locks in place.</li> <li>2. Make sure Charger is connected and operating properly. Give enough time for Battery Pack to recharge properly.</li> <li>3. Dispose of old Battery Pack properly or recycle. Replace Battery Pack.</li> <li>4. Have technician service tool.</li> </ol>
Tool operates slowly.	<ol style="list-style-type: none"> <li>1. Forcing tool to work too fast.</li> <li>2. Battery Pack wearing out.</li> </ol>	<ol style="list-style-type: none"> <li>1. Allow tool to work at its own rate.</li> <li>2. Dispose of old Battery Pack properly or recycle. Replace Battery Pack.</li> </ol>
Excessive noise or rattling.	Internal damage or wear. (Bearings, for example.)	Have technician service tool.
Overheating.	<ol style="list-style-type: none"> <li>1. Forcing tool to work too fast.</li> <li>2. Blocked motor housing vents.</li> </ol>	<ol style="list-style-type: none"> <li>1. Allow tool to work at its own rate.</li> <li>2. Wear ANSI-approved safety goggles and NIOSH-approved dust mask/respirator while blowing dust out of motor using compressed air.</li> </ol>



**Follow all safety precautions whenever diagnosing or servicing the tool.  
Disconnect Battery Pack and Charger power supply before service.**

## PLEASE READ THE FOLLOWING CAREFULLY

THE MANUFACTURER AND/OR DISTRIBUTOR HAS PROVIDED THE PARTS LIST AND ASSEMBLY DIAGRAM IN THIS MANUAL AS A REFERENCE TOOL ONLY. NEITHER THE MANUFACTURER OR DISTRIBUTOR MAKES ANY REPRESENTATION OR WARRANTY OF ANY KIND TO THE BUYER THAT HE OR SHE IS QUALIFIED TO MAKE ANY REPAIRS TO THE PRODUCT, OR THAT HE OR SHE IS QUALIFIED TO REPLACE ANY PARTS OF THE PRODUCT. IN FACT, THE MANUFACTURER AND/OR DISTRIBUTOR EXPRESSLY STATES THAT ALL REPAIRS AND PARTS REPLACEMENTS SHOULD BE UNDERTAKEN BY CERTIFIED AND LICENSED TECHNICIANS, AND NOT BY THE BUYER. THE BUYER ASSUMES ALL RISK AND LIABILITY ARISING OUT OF HIS OR HER REPAIRS TO THE ORIGINAL PRODUCT OR REPLACEMENT PARTS THERETO, OR ARISING OUT OF HIS OR HER INSTALLATION OF REPLACEMENT PARTS THERETO.

## Parts List and Diagram

### Parts List and Diagram

SAFETY

SETUP

OPERATION

MAINTENANCE

Part	Description	Qty
1-1	Harness	1
1-2	Screw	5
1-3	Nut	2
1-4	Screw	2
2-1	Turbo Button	1
2-2	Spring	1
2-3	Left Handle	1
2-4	Light Panel	1
2-5	Trigger Lock	1
2-6	Washer	1
2-7	O-Ring	1
2-8	Fixed Seat	1
2-9	Speed Control Switch	1
2-10	Right Handle	1
2-11	Screw	9
2-12	Wire Harness Assembly	1
2-13	Handle Knob	1
2-14	Handle Bolt	1
2-15	Trigger	1
2-16	Wire Retaining Plate	1
2-17	Micro Switch	1
3-1	Nozzle	1
3-2	Lower Tube	2
3-3	Upper Tube	1
3-4	Sealing Strip	1
3-5	Connecting Ring	1
3-6	Hose Clamp	1
3-7	Hose Clamp Screw	2
3-8	Nut	2
3-9	Flex Tube	1
3-10	Hose Clamp	1
3-11	Elbow	1

Part	Description	Qty
3-12	O-ring	1
4-1	Screw	46
4-2	Rear Cover	1
4-3	Nut	4
4-4	Spring Cover	2
4-5	Spring	4
4-6	Spring Base	2
4-7	Cover	1
4-8	Front Housing	1
4-9	Wire Retaining Plate	1
4-10	PCBA	1
4-11	U-Clip	1
4-12	Muffler	1
4-13	Muffler	1
4-14	Battery Compartment	1
4-15	Male Terminal	2
4-16	Pressplate	2
4-17	Front Cover	1
5-1	Ducting Rear End	1
5-2	Motor	1
5-3	Shock Pad	4
5-4	Ducting	1
5-5	Screw	3
5-6	Impeller	1
5-7	Flange Nut	1
6-1	Backplate	1
6-2	Grommet	4
6-3	Gasket	4
6-4	Bolt	4
6-5	Shock Pad	2
6-6	Base	1
6-7	Screw	4

Record Product's Date Code Here: \_\_\_\_\_

**Note:** If product has no Date Code, record month and year of purchase instead.

**Note:** Some parts are listed and shown for illustration purposes only, and are not available individually as replacement parts. Specify UPC 193175578556 when ordering parts.

# Parts List and Diagram

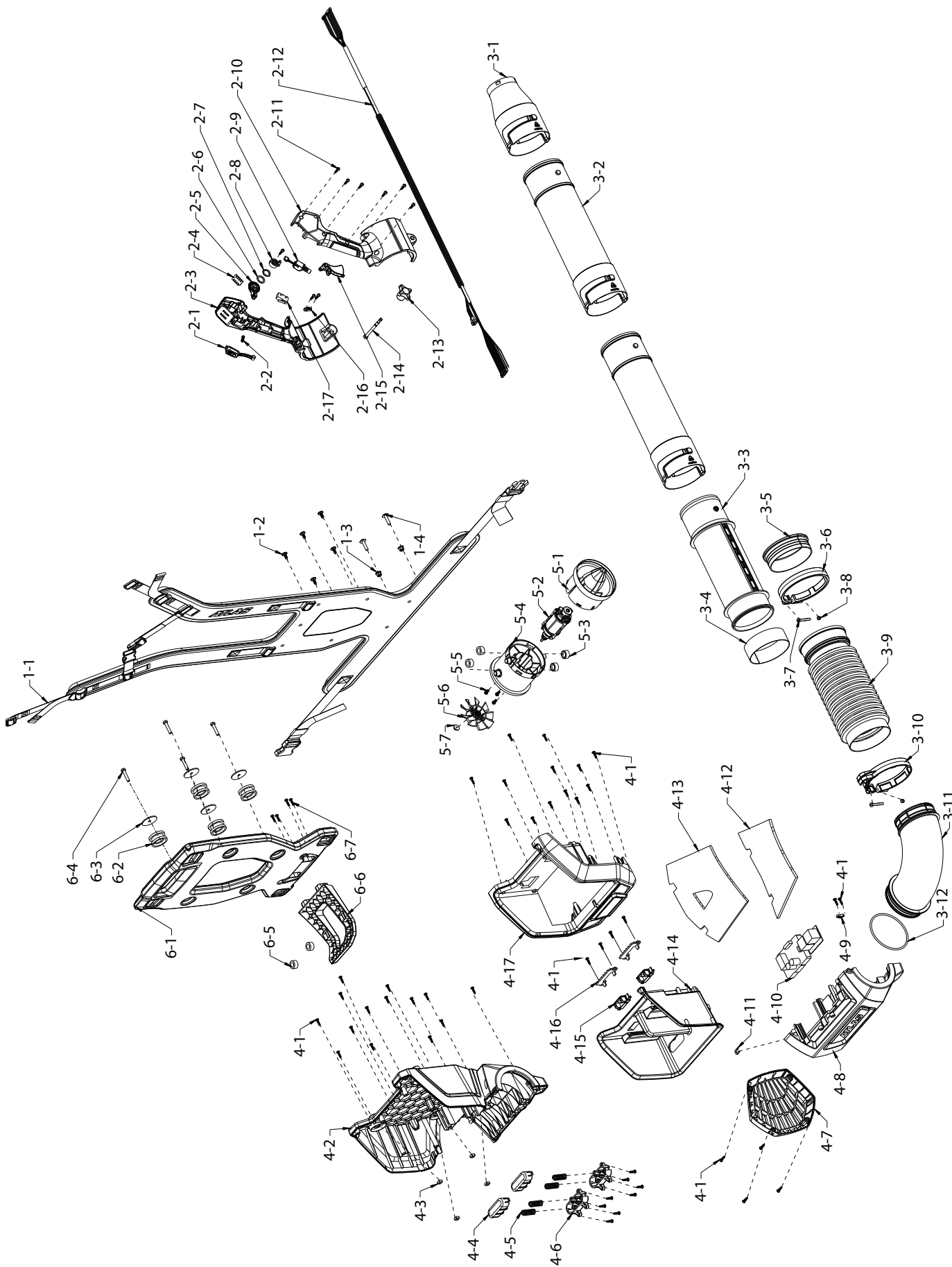

SAFETY

SETUP

OPERATION

MAINTENANCE

## Limited 90 Day Warranty

Harbor Freight Tools Co. makes every effort to assure that its products meet high quality and durability standards, and warrants to the original purchaser that this product is free from defects in materials and workmanship for the period of 90 days from the date of purchase. This warranty does not apply to damage due directly or indirectly, to misuse, abuse, negligence or accidents, repairs or alterations outside our facilities, criminal activity, improper installation, normal wear and tear, or to lack of maintenance. We shall in no event be liable for death, injuries to persons or property, or for incidental, contingent, special or consequential damages arising from the use of our product. Some states do not allow the exclusion or limitation of incidental or consequential damages, so the above limitation of exclusion may not apply to you. THIS WARRANTY IS EXPRESSLY IN LIEU OF ALL OTHER WARRANTIES, EXPRESS OR IMPLIED, INCLUDING THE WARRANTIES OF MERCHANTABILITY AND FITNESS.

To take advantage of this warranty, the product or part must be returned to us with transportation charges prepaid. Proof of purchase date and an explanation of the complaint must accompany the merchandise. If our inspection verifies the defect, we will either repair or replace the product at our election or we may elect to refund the purchase price if we cannot readily and quickly provide you with a replacement. We will return repaired products at our expense, but if we determine there is no defect, or that the defect resulted from causes not within the scope of our warranty, then you must bear the cost of returning the product.

This warranty gives you specific legal rights and you may also have other rights which vary from state to state.

# ***ATLAS***

# Owner's Manual & Safety Instructions

Save This Manual Keep this manual for the safety warnings and precautions, assembly, operating, inspection, maintenance and cleaning procedures. Write the product's serial number in the back of the manual near the assembly diagram (or month and year of purchase if product has no number). Keep this manual and the receipt in a safe and dry place for future reference.

20g

# ATLAS™

## 40V AND 80V CHARGERS



Visit our website at: <http://www.harborfreight.com>  
Email our technical support at: [productsupport@harborfreight.com](mailto:productsupport@harborfreight.com)





When unpacking, make sure that the product is intact and undamaged. If any parts are missing or broken, please call 1-888-866-5797 as soon as possible.

Copyright© 2020 by Harbor Freight Tools®. All rights reserved.  
No portion of this manual or any artwork contained herein may be reproduced in any shape or form without the express written consent of Harbor Freight Tools. Diagrams within this manual may not be drawn proportionally. Due to continuing improvements, actual product may differ slightly from the product described herein. Tools required for assembly and service may not be included.

### **⚠ WARNING**

Read this material before using this product.  
Failure to do so can result in serious injury.  
**SAVE THIS MANUAL.**

**WARNING SYMBOLS AND DEFINITIONS**

	This is the safety alert symbol. It is used to alert you to potential personal injury hazards. Obey all safety messages that follow this symbol to avoid possible injury or death.
	Indicates a hazardous situation which, if not avoided, will result in death or serious injury.
	Indicates a hazardous situation which, if not avoided, could result in death or serious injury.
	Indicates a hazardous situation which, if not avoided, could result in minor or moderate injury.
	Addresses practices not related to personal injury.

# IMPORTANT SAFETY INFORMATION

## Charger Safety Warnings

**⚠️WARNING**

Read all safety warnings and all instructions.

*Failure to follow the warnings and instructions may result in electric shock, fire and/or serious injury.*

Save all warnings and instructions for future reference.

The warnings, precautions, and instructions discussed in this instruction manual cannot cover all possible conditions and situations that may occur. It must be understood by the operator that common sense and caution are factors which cannot be built into this product, but must be supplied by the operator.

1.  The battery Charger gets hot during use. The Charger's heat can build up to unsafe levels and create a fire hazard if it does not receive adequate ventilation, due to an electrical fault, or if it is used in a hot environment. Do not place the Charger on a flammable surface. Do not obstruct any vents on the Charger. **Especially avoid placing the Charger on carpets and rugs; they are not only flammable, but they also obstruct vents under the Charger.** Place the Charger on a stable, solid, nonflammable surface (such as a stable metal workbench or concrete floor) at least 1 foot away from all flammable objects, such as drapes or walls. Keep a fire extinguisher and a smoke detector in the area. Frequently monitor the Charger and Battery Pack while charging.
2. **Charge only designated Battery Packs; others may overheat, leak, or burst.**
3. **Follow charging instructions.**
4. **Do not insert damaged Battery Pack.**
5. **Check frequently while charging.**
6. **Wear ANSI-approved safety goggles during use.**
7. **Use chargers only with specifically designated Battery Packs.** *Use of any other Battery Packs may create a risk of injury and fire.*
8. **When Battery Pack is not in use, keep it away from other metal objects, like paper clips, coins, keys, nails, screws or other small metal objects, that can make a connection from one terminal to another.** *Shorting the Battery Pack terminals together may cause burns or a fire.*
9. **Under abusive conditions, liquid may be ejected from the Battery Pack; avoid contact. If contact accidentally occurs, flush with water. If liquid contacts eyes, additionally seek medical help.** *Liquid ejected from the battery pack may cause irritation or burns.*
10. Do not expose chargers to rain or wet conditions. Water entering a Charger will increase the risk of electric shock. Charge indoors only.
11. Keep charging area clean and well lit. Cluttered or dark areas invite accidents.
12. Do not operate chargers in explosive atmospheres, such as in the presence of flammable liquids, gases or dust. Chargers create sparks which may ignite the dust or fumes.
13. Charger plugs must match the outlet. Never modify the plug in any way. Unmodified plugs and matching outlets will reduce risk of electric shock.
14. Do not abuse the cord. Never use the cord for carrying, pulling or unplugging the Charger. Keep cord away from heat, oil, sharp edges or moving parts. Damaged or entangled cords increase the risk of electric shock.

15. Store idle chargers out of the reach of children and do not allow persons unfamiliar with the Charger or these instructions to operate the Charger.
16. Maintain chargers. Check for breakage of parts and any other condition that may affect the Charger's operation. If damaged, have the Charger repaired before use.
17. Have your Charger serviced by a qualified repair person using only identical replacement parts. This will ensure that the safety of the Charger is maintained.
18. Inspect before every use; do not use if parts are loose or damaged.
19. Use as intended only.
20. Unplug after use and before service, cleaning or storage.
21. Maintain labels and nameplates on the Charger. These carry important safety information. If unreadable or missing, contact Harbor Freight Tools for a replacement.
22. This product is not a toy. Keep it out of reach of children.
23. People with pacemakers should consult their physician(s) before use. Electromagnetic fields in close proximity to heart pacemaker could cause pacemaker interference or pacemaker failure. In addition, people with pacemakers should properly maintain and inspect to avoid electrical shock.

## Lithium Battery Safety Warnings

---



**LITHIUM BATTERIES STORE A LARGE AMOUNT OF ENERGY AND WILL VENT FIRE OR EXPLODE IF MISTREATED:**



1. **DO NOT DO ANY OF THE FOLLOWING TO THE BATTERY PACK:**
  - a. **Open,**
  - b. **Drop,**
  - c. **Short-circuit,**
  - d. **Puncture,**
  - e. **Incinerate, or**
  - f. **Expose to temperatures greater than 140°F.**
2. **Keep Battery Pack dry.**
3. Charge Battery Pack only according to its Charger's instructions.
4. Inspect Battery Pack before every use; do not use or charge if damaged.



**SAVE THESE INSTRUCTIONS.**

## Grounding

### ⚠WARNING



#### TO PREVENT ELECTRIC SHOCK AND DEATH FROM INCORRECT GROUNDING:

Check with a qualified electrician if you are in doubt as to whether the outlet is properly grounded. Do not modify the power cord plug provided with the charger. Do not use the charger if the power cord or plug is damaged. If damaged, have it repaired by a service facility before use. If the plug will not fit the outlet, have a proper outlet installed by a qualified electrician.

## Extension Cords

**Note:** Extension cords must not be used with this Charger.

## Symbology

	Double Insulated
	Volts
	Alternating Current
	Amperes
	WARNING marking concerning Risk of Eye Injury. Wear ANSI-approved safety goggles with side shields.

	Read the manual before set-up and/or use.
	WARNING marking concerning Risk of Fire. Do not cover Charger ventilation ducts. Keep flammable objects away. Charge on fireproof surface only.
	WARNING marking concerning Risk of Electric Shock. Properly connect power cord to appropriate outlet. Properly connect Charger's power cord to appropriate outlet.

## Specifications

	<b>56993</b>	<b>56997</b>
Input Rating	120VAC / 60Hz / 2A	120VAC / 60Hz / 3A
Output Rating	40VDC / 2A	40VDC / 5A
Compatible Battery Types	Atlas Li-Ion 40V (57008) or 40/80V (57014) (sold separately)	
Operating Temperature	43°- 104°F	

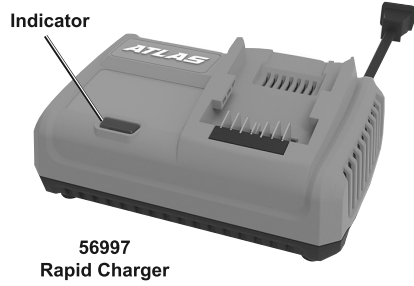
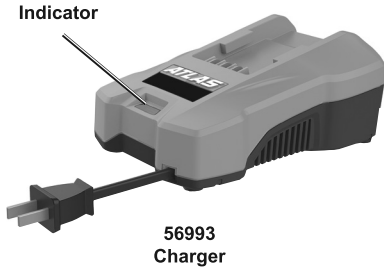

## Operating Instructions



Read the **ENTIRE IMPORTANT SAFETY INFORMATION** section at the beginning of this manual including all text under subheadings therein before set up or use of this product.

1. Place the Battery Pack on a dry fireproof surface in a room where the temperature is from 43°- 104°F.

**Note:** If recharging a newly spent Battery Pack, allow it to cool completely before charging.

2. Examine the Battery Pack.  
It must be undamaged, and an Atlas Li-Ion 40V or 40V/80V Battery Pack. **Do not charge a cracked, open, or leaking Battery Pack, or charge a non-recommended type of Battery Pack.**
3. The Atlas Battery Pack's terminals are designed to fit this Charger specifically. If the Battery Pack does not fit the Charger properly, do not try to insert it. **Do not force a Battery Pack into the Charger.**
4. Plug the Charger directly into a grounded, 120VAC, 60Hz receptacle. The Indicator will flash green every 5 seconds when the charger is ready to charge a Battery Pack.
5. Slide the Battery Pack into the Charger. The Indicator will blink green while the Battery Pack is charging.

**Note:** If the Indicator blinks red instead, the Battery Pack could not be charging properly. Check that connections are clean and tight, and that Battery Pack and Charger are both at proper charging temperature. If that does not allow the Battery Pack to charge properly, it may be worn out or internally damaged. Do the below:

- a. Remove the Battery Pack from the Charger. Unplug the Charger to reset it.
- b. After one minute, plug the Charger back into the receptacle. Then, slide the Battery Pack into the Charger.
- c. If the indicator flashes red again, the Battery Pack is defective, remove it from the Charger. Do not leave a worn out or internally damaged Battery Pack in the Charger.

**Note:** If the Indicator is solid red, the Battery Pack and/or Charger are at an incorrect charging temperature. Charging room temperature: 43°- 104°F. Make sure that both Charger and Battery Pack are at the correct charging temperature. Allow sufficient time for both of them to cool off or warm up as needed.

6. While charging, the Battery Pack and Charger may become warm to the touch. This is normal and does not indicate a problem.
7. The Indicator will light up constant green when the Battery Pack is charged.
8. Allow the Battery Pack to cool completely before using it.
9. Unplug the Charger when not in use.

## Maintenance and Servicing



Procedures not specifically explained in this manual must be performed only by a qualified technician.

### **WARNING**

**TO PREVENT SERIOUS INJURY FROM ACCIDENTAL OPERATION:**  
Remove the Battery Pack and unplug the charger before performing any inspection, maintenance, or cleaning procedures.

**TO PREVENT SERIOUS INJURY FROM TOOL FAILURE:**  
Do not use damaged equipment.

If damage is noted, have the problem corrected before further use.

- BEFORE EACH USE**, inspect the general condition of the charger. Check for:
  - loose hardware,
  - misalignment or binding of moving parts,
  - cracked or broken parts,
  - damaged electrical wiring, and
  - any other condition that may affect its safe operation.
- AFTER USE**, wipe external surfaces of the charger with clean cloth.
- Disconnect Battery Pack and store Charger and any Battery Packs in a dry, indoor area out of reach of children and away from metal objects (i.e., paperclips, coins) to prevent shorting.

**WARNING! TO PREVENT SERIOUS INJURY AND DEATH FROM ELECTRIC SHOCK:**  
Do not open Charger.  
Do not service internal parts.

### FCC Statement

**Note:** This equipment has been tested and found to comply with the limits for a Class B digital device, pursuant to part 15 of the FCC Rules. These limits are designed to provide reasonable protection against harmful interference in a residential installation. This equipment generates, uses and can radiate radio frequency energy and, if not installed and used in accordance with the instructions, may cause harmful interference to radio communications. However, there is no guarantee that interference will not occur in a particular installation. If this equipment does cause harmful interference to radio or television reception, which can be determined by turning the equipment off and on, the user is encouraged to try to correct the interference by one or more of the following measures:

- Reorient or relocate the receiving antenna.
- Increase the separation between the equipment and receiver.
- Connect the equipment into an outlet on a circuit different from that to which the receiver is connected.
- Consult the dealer or an experienced radio/TV technician for help.

**Record Product's Serial Number Here:** \_\_\_\_\_

**Note:** If product has no serial number, record month and year of purchase instead.

**Note:** Replacement parts are not available for this item.

## Limited 90 Day Warranty

Harbor Freight Tools Co. makes every effort to assure that its products meet high quality and durability standards, and warrants to the original purchaser that this product is free from defects in materials and workmanship for the period of 90 days from the date of purchase. This warranty does not apply to damage due directly or indirectly, to misuse, abuse, negligence or accidents, repairs or alterations outside our facilities, criminal activity, improper installation, normal wear and tear, or to lack of maintenance. We shall in no event be liable for death, injuries to persons or property, or for incidental, contingent, special or consequential damages arising from the use of our product. Some states do not allow the exclusion or limitation of incidental or consequential damages, so the above limitation of exclusion may not apply to you. THIS WARRANTY IS EXPRESSLY IN LIEU OF ALL OTHER WARRANTIES, EXPRESS OR IMPLIED, INCLUDING THE WARRANTIES OF MERCHANTABILITY AND FITNESS.

To take advantage of this warranty, the product or part must be returned to us with transportation charges prepaid. Proof of purchase date and an explanation of the complaint must accompany the merchandise. If our inspection verifies the defect, we will either repair or replace the product at our election or we may elect to refund the purchase price if we cannot readily and quickly provide you with a replacement. We will return repaired products at our expense, but if we determine there is no defect, or that the defect resulted from causes not within the scope of our warranty, then you must bear the cost of returning the product.

This warranty gives you specific legal rights and you may also have other rights which vary from state to state.

# ***ATLAS***<sup>TM</sup>

26541 Agoura Road • Calabasas, CA 91302 • 1-888-866-5797