

CENTRAL PNEUMATIC®

**AIR JITTERBUG
ORBITAL SANDER**

Model 90115

**ASSEMBLY and OPERATING
INSTRUCTIONS**



3491 Mission Oaks Blvd., Camarillo, CA 93011
Visit our Web site at <http://www.harborfreight.com>

Copyright © 2003 by Harbor Freight Tools®. All rights reserved. No portion of this manual or any artwork contained herein may be reproduced in any shape or form without the express written consent of Harbor Freight Tools.

For technical questions and replacement parts, please call 1-800-444-3353

Specifications

Orbits Per Minute	9400 OPM
Air Inlet	1/4" - 18 NPT
Recommended Air Pressure	90 -100 PSI (maximum)
Air Consumption	8.5 CFM @ 90 PSI
Pad Size	6-1/2" x 3-1/2"
Sandpaper Size	8-1/2" x 3-1/2"
Tool Weight	4.1 Lbs.

Sandpaper Available at Harbor Freight Tools

Save This Manual

You will need the manual for the safety warnings and precautions, assembly instructions, operating and maintenance procedures, parts list and diagram. Keep your invoice with this manual. Write the invoice number on the inside of the front cover. Keep the manual and invoice in a safe and dry place for future reference.

Safety Warnings and Precautions

WARNING: When using tool, basic safety precautions should always be followed to reduce the risk of personal injury and damage to equipment.

Read all instructions before using this tool!

1. **Keep work area clean.** Cluttered areas invite injuries.
2. **Observe work area conditions.** Do not use machines or power tools in damp or wet locations. Don't expose to rain. Keep work area well lighted. Do not use electrically powered tools in the presence of flammable gases or liquids.
3. **Keep children away.** Children must never be allowed in the work area. Do not let them handle machines, tools, extension cords, or air hoses.
4. **Store idle equipment.** When not in use, tools must be stored in a dry location to inhibit rust. Always lock up tools and keep out of reach of children.
5. **Use the right tool for the job.** Do not attempt to force a small tool or attachment to do the work of a larger industrial tool. There are certain applications for which this tool was designed. It will do the job better and more safely at the rate for which it was intended. Do not modify this tool and do not use this tool for a purpose for which it was not intended.
6. **Dress properly.** Do not wear loose clothing or jewelry as they can be caught in moving parts. Protective, electrically non-conductive clothes and non-skid footwear are recommended when working. Wear restrictive hair covering to contain long hair.
7. **Use eye and ear protection.** Always wear ANSI approved impact safety goggles. Wear a full face shield if you are producing sawdust. Wear an ANSI approved dust mask or respirator when working around wood, and chemical dusts and mists.

8. **Do not overreach.** Keep proper footing and balance at all times. Do not reach over or across running machines or air hoses.
9. **Maintain tools with care.** Keep tools clean for better and safer performance. Follow instructions for lubricating and changing accessories. Inspect tool cords and air hoses periodically and, if damaged, have them repaired by an authorized technician. The handles must be kept clean, dry, and free from oil and grease at all times.
10. **Disconnect air supply.** Disconnect air hose when not in use.
11. **Do not force tool.** It will do a better job more safely at the rate at which it is intended.
12. **Avoid unintentional starting.** Be sure the Lever is in the Off position (up) when not in use and before plugging in. Do not carry any tool with your hand on the lever.
13. **Stay alert.** Watch what you are doing, use common sense. Do not operate any tool when you are tired.
14. **Check for damaged parts.** Before using any tool, any part that appears damaged should be carefully checked to determine that it will operate properly and perform its intended function. Check for alignment and binding of moving parts; any broken parts or mounting fixtures; and any other condition that may affect proper operation. Any part that is damaged should be properly repaired or replaced by a qualified technician. Do not use the tool if any switch does not turn On and Off properly.
15. **Guard against electric shock.** Prevent body contact with grounded surfaces such as pipes, radiators, ranges, and refrigerator enclosures.
16. **Replacement parts and accessories.** When servicing, use only identical replacement parts. Use of any other parts will void the warranty. Only use accessories intended for use with this tool. Approved accessories are available from Harbor Freight Tools.
17. **Do not operate tool is under the influence of alcohol or drugs.** Read warning labels if taking prescription medicine to determine if your judgement or reflexes are impaired while taking drugs. If there is any doubt, do not operate the Sander.
18. **Use proper size and type extension cord.** If an extension cord is required, it must be of the proper size and type to supply the correct current to the tool without heating up. Otherwise, the extension cord could melt and catch fire, or cause electrical damage to the tool. Check your compressor's manual for the appropriate size cord.
19. **Maintenance.** For your safety, maintenance should be performed regularly by a qualified technician.
20. **Compressed air only.** Never use combustible gases as a power source.
21. **INDUSTRIAL APPLICATIONS MUST FOLLOW OSHA REQUIREMENT.**

Note: Performance of the compressor (if powered by line voltage) may vary depending on variations in local line voltage. Extension cord usage may also affect tool performance.

Warning: The warnings, cautions, and instructions discussed in this instruction manual cannot cover all possible conditions and situations that may occur. It must be understood by the operator that common sense and caution are factors which cannot be built into this product, but must be supplied by the operator.

Unpacking

When unpacking, check to make sure the parts listed on page 6 are included. If any parts are missing or broken, please call Harbor Freight Tools at the number on the cover of this manual as soon as possible.

Operation

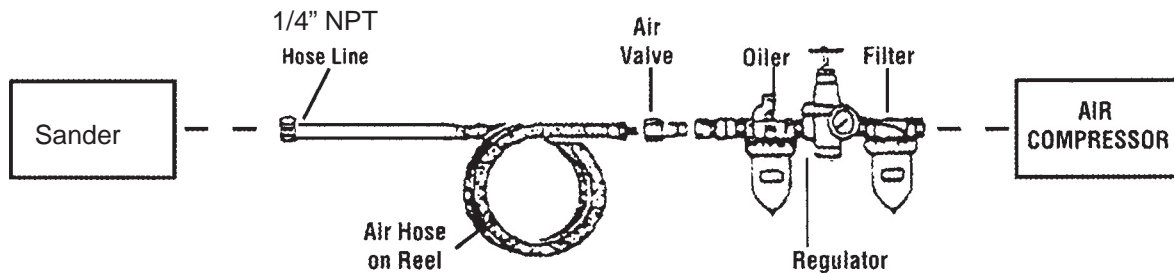

Recommended Air Line Components

For best service you should incorporate an oiler, regulator, and inline filter, as shown in the diagram above. Hoses, couplers, oilers, regulators, and filters are all available at Harbor Freight Tools.

1. You will need to prepare a 1/4" air connector (sold separately) to connect to the air inlet on the Sander. First, wrap the 1/4" air connector (not included) with pipe thread seal tape before threading into Air Inlet (#11). Connect the 3/8" I.D. Air Source Hose (not included) to the Sander.

Note: If you are not using an automatic oiler system, before operation, add a few drops of Pneumatic Tool Oil to the airline connection. Add a few drops more after each hour of continual use.

2. Set the air pressure on your compressor to 90 PSI. Do not exceed the recommended air pressure of 100 PSI.

3. Check the air connection for leaks. Then, disconnect the Sander from the air hose and turn off the air compressor.

WARNING: Some dust created by power sanding, sawing, grinding, drilling, and other construction activities, contain chemicals known [to the State of California] to cause cancer, birth defects or other reproductive harm. Some examples of these chemicals are:

- Lead from lead-based paints
- Crystalline silica from bricks and cement or other masonry products
- Arsenic and chromium from chemically treated lumber

Your risk from these exposures varies, depending on how often you do this type of work. To reduce your exposure to these chemicals: work in a well ventilated area, and work with approved safety equipment, such as those dust masks that are specially designed to filter out microscopic particles.

(California Health & Safety Code 25249.5, *et seq.*)

Operation (continued)

Note: Sandpaper is not included.

Note: The Sander must be disconnected from the air hose before attaching sandpaper.

Attaching Sandpaper. Sandpaper is available at Harbor Freight Tools. You may have to cut it to size

1. Push down on the Clamp Lever and it will release the **Paper Clamp (#41)**.

See **FIGURE 1**.

2. Insert one end of the sandpaper under the **Paper Clamp (#41)** and snap it closed. Repeat the process with the rear **Paper Clamp (#41)**.

FIGURE 1

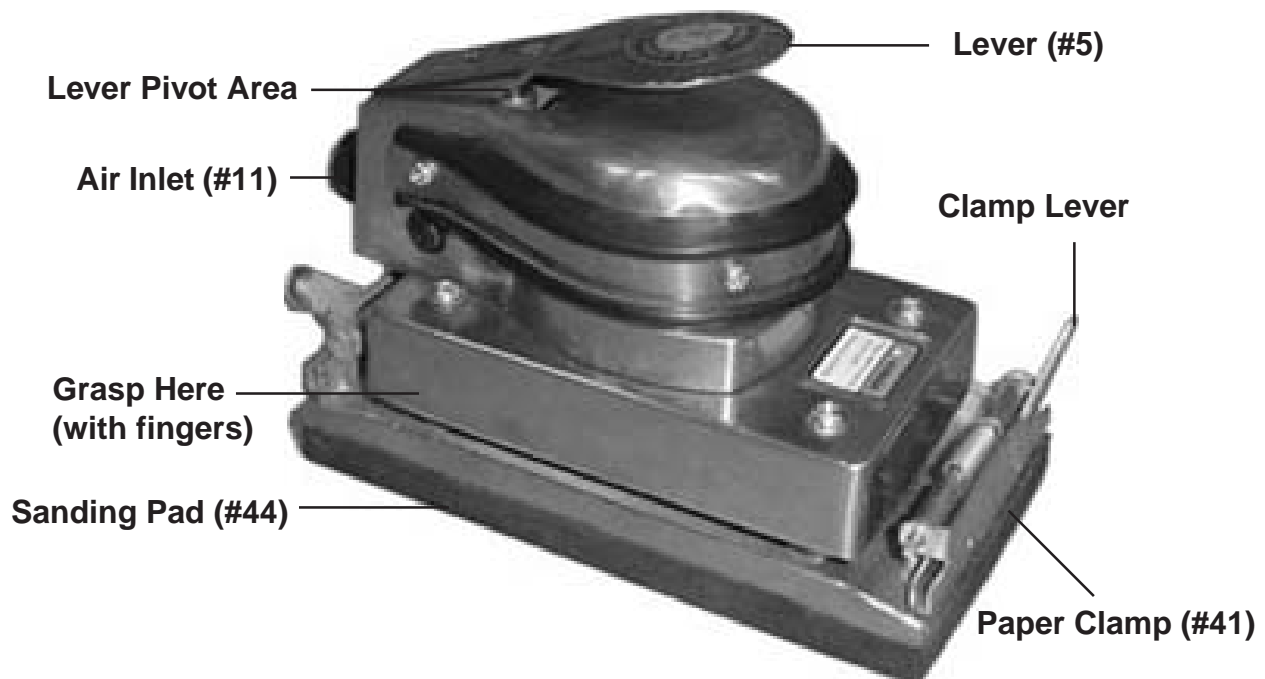

3. Check that the sandpaper fits snugly against the **Sanding Pad (#44)**. If not, repeat the process above and pull the sandpaper more tightly against the **Sanding Pad (#44)**.

4. Connect the sander to the air compressor.

5. Set the compressor to 90 PSI. Do not exceed 100 PSI.

6. If applicable, secure your workpiece. Use appropriate clamping devices if applicable.

7. Before starting the Sander, place it on the workpiece. If you start the Sander before you contact the workpiece, the Sander may vibrate out of your hand once you contact the workpiece.

8. To operate, press the **Lever (#5)** with the palm of your hand while using your fingers to grasp the Sander. See **FIGURE 1**. The further you press down on the **Lever (#5)**, the faster the Sander will rotate. For fine tuning the air pressure, adjust the **Regulator Knob (#7)**.

9. Do not apply force or pressure. Allow the Sander to do the work for you.

Note: During operation, use your other hand to keep the air hose clear of the Sander.

10. When finished, release the **Lever (#5)** and disconnect the air hose from the Sander.

Parts List

Part No.	Description	Qty.	Part No.	Description	Qty.
1	Housing	1	24	O-ring Cylinder	1
2	Rubber Sheathing	1	25	Pin Cylinder	1
3	Housing Clamp	1	26	Axle	1
4	Screw	4	27	Key Tab	1
5	Lever	1	28	Washer	1
6	Lever Pin	1	29	Base	1
7	Regulator Knob	1	30	Spring Screw	13
8	Regulator Screw	4	31	Screw	8
9	E-Pin	1	32	Spacer	4
10	O-ring	1	33	Clamp Nut Screw	2
11	Air Inlet	1	34	Clamp Nut Screw	2
12	O-ring	1	35	Accentive Ring	1
13	Spring	1	36	Screw	1
14	O-ring	1	37	Bearing Housing	1
15	Spring	1	38	Bearing Gasket	1
16	O-ring	1	39	V-Gasket	1
17	Exhaust	1	40	Bearing Screw	1
18	E-Screw	1	41	Paper Clamp	2
19	Rear End Bearing	3	42	Base	1
20	Rear End Plate	2	43	Base Screw	12
21	Rotor	1	44	Sanding Pad	1
22	Rotor Blade	5	45	Cross Screw Cap	1
23	Cylinder	1			

PLEASE READ THE FOLLOWING CAREFULLY

THE MANUFACTURER AND/OR DISTRIBUTOR HAS PROVIDED THE PARTS DIAGRAM IN THIS MANUAL AS A REFERENCE TOOL ONLY. NEITHER THE MANUFACTURER NOR DISTRIBUTOR MAKES ANY REPRESENTATION OR WARRANTY OF ANY KIND TO THE BUYER THAT HE OR SHE IS QUALIFIED TO MAKE ANY REPAIRS TO THE PRODUCT OR THAT HE OR SHE IS QUALIFIED TO REPLACE ANY PARTS OF THE PRODUCT. IN FACT, THE MANUFACTURER AND/OR DISTRIBUTOR EXPRESSLY STATES THAT ALL REPAIRS AND PARTS REPLACEMENTS SHOULD BE UNDERTAKEN BY CERTIFIED AND LICENSED TECHNICIANS AND NOT BY THE BUYER. THE BUYER ASSUMES ALL RISK AND LIABILITY ARISING OUT OF HIS OR HER REPAIRS TO THE ORIGINAL PRODUCT OR REPLACEMENT PARTS THERETO, OR ARISING OUT OF HIS OR HER INSTALLATION OF REPLACEMENT PARTS THERETO.

NOTE: Some parts are listed and shown for illustration purposes only and are not available individually as replacement parts.

Assembly Drawing

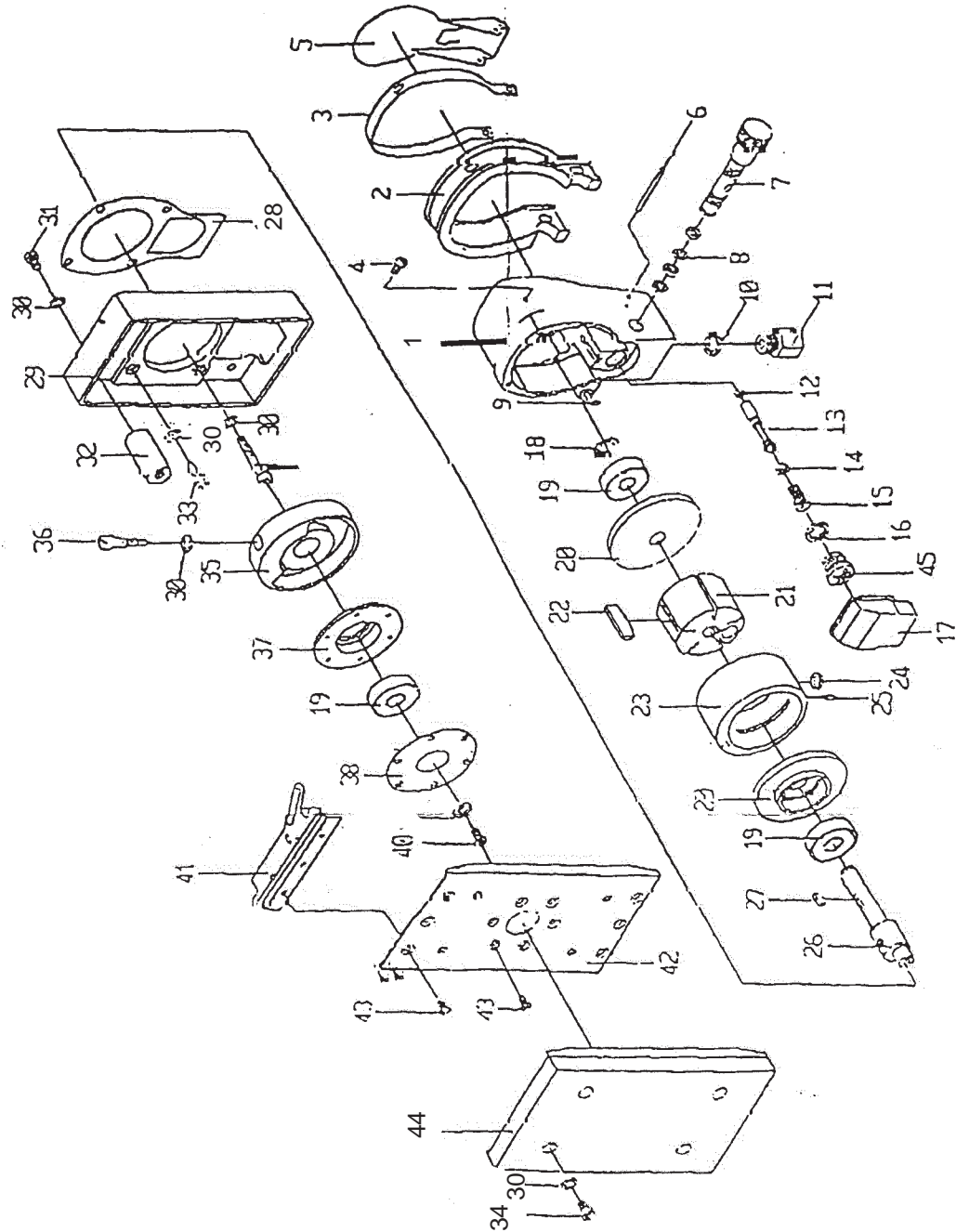

Maintenance

Warning! Disconnect the Sander from the air source before doing any maintenance.

1. Before each use check the sandpaper. If it is worn or torn, replace it.
2. Before each use apply a few drops of Pneumatic Tool Oil to the Lever pivot area. See **FIGURE 1** on page 5.
3. Wipe down the Sander after each use. Do not use solvents or abrasive chemicals to clean the Sander.

90 Day Warranty

Harbor Freight Tools Co. makes every effort to assure that its products meet high quality and durability standards, and warrants to the original purchaser that this product is free from defects in materials and workmanship for the period of 90 days from the date of purchase. This warranty does not apply to damage due directly or indirectly, to misuse, abuse, negligence or accidents, repairs or alterations outside our facilities, criminal activity, improper installation, normal wear and tear, or to lack of maintenance. We shall in no event be liable for death, injuries to persons or property, or for incidental, contingent, special or consequential damages arising from the use of our product. Some states do not allow the exclusion or limitation of incidental or consequential damages, so the above limitation of exclusion may not apply to you. THIS WARRANTY IS EXPRESSLY IN LIEU OF ALL OTHER WARRANTIES, EXPRESS OR IMPLIED, INCLUDING THE WARRANTIES OF MERCHANTABILITY AND FITNESS.

To take advantage of this warranty, the product or part must be returned to us with transportation charges prepaid. Proof of purchase date and an explanation of the complaint must accompany the merchandise. If our inspection verifies the defect, we will either repair or replace the product at our election or we may elect to refund the purchase price if we cannot readily and quickly provide you with a replacement. We will return repaired products at our expense, but if we determine there is no defect, or that the defect resulted from causes not within the scope of our warranty, then you must bear the cost of returning the product.

This warranty gives you specific legal rights and you may also have other rights which vary from state to state.

3491 Mission Oaks Blvd. • PO Box 6009 • Camarillo, CA 93011 • (800) 444-3353