

TO START



IMPORTANT: SEE MANUAL FOR DETAILED INSTRUCTIONS OF THESE PROCEDURES.

5

- A. Follow SET-UP on Reverse.
- B. Close Chuck Guard.

STOP: MAKE SURE ALL FRONT CONTROLS ARE SET TO "OFF" OR "0".

- C. Plug in the Lathe.
- D. Move Forward-OFF-Reverse Switch to desired direction.
- E. Move Power Switch to "ON" position.
- F. Turn Variable Speed Control Knob to desired speed.

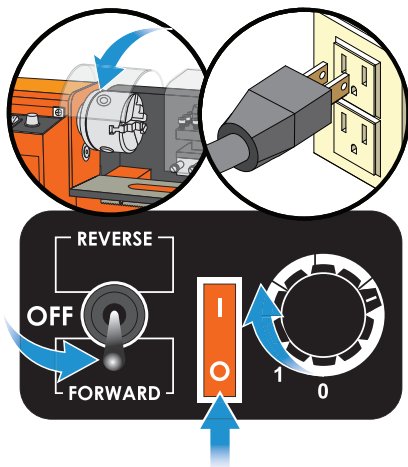

TO STOP

6

- A. Turn Variable Speed Control Knob to "0".
- B. Move Forward-OFF-Reverse Switch to "OFF" position.
- C. Move Power Switch to "OFF" position.
- D. Unplug the Lathe.

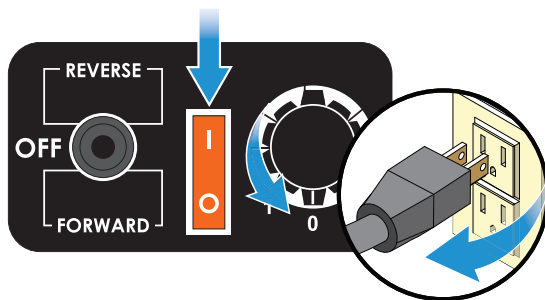

QUICK START GUIDE

7" x 12" PRECISION MINI LATHE

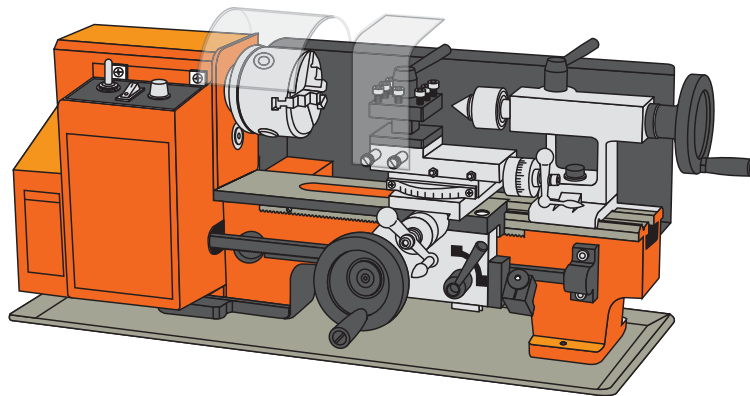

Read the user manual completely before using this product. Failure to do so can result in serious injury.

Always wear ANSI-approved eye protection before using this product

SET UP

1 Unplug Lathe.

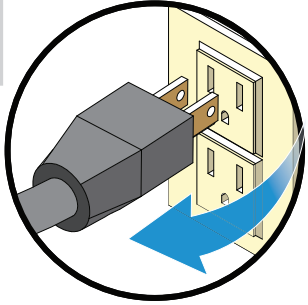

2 Install required Jaws into Chuck.

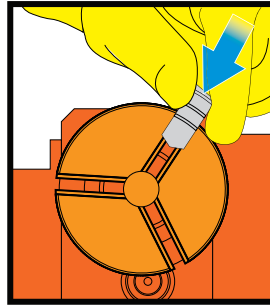

3 Set up workpiece:

- A. Secure workpiece.
- B. Install cutting tool (sold separately) in Tool Post.
- C. Set Automatic Feed Lever.
- D. If threading, set Threading Dial.

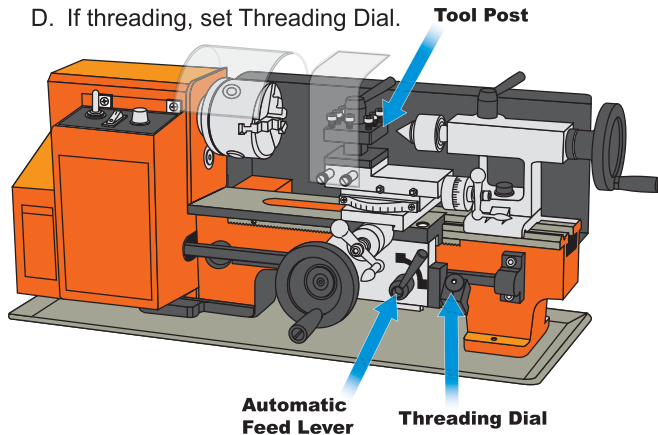

SET UP

4 Adjust Controls before Start.

- A. Set Spindle speed with H/L Gear Shift Lever.
- B. Set feed direction with Feed Direction Selector.

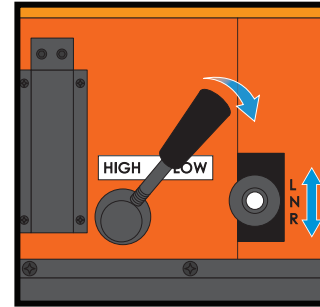

Back Controls

STOP: MAKE SURE ALL FRONT CONTROLS ARE SET TO "OFF" OR "0".

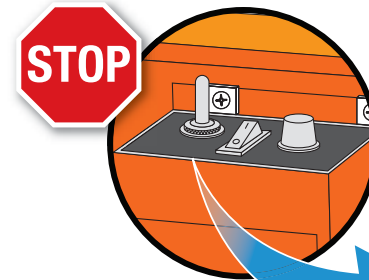

Front Controls

