

CENTRALPNEUMATIC®

4" AIR ANGLE GRINDER

Model 95504

ASSEMBLY AND OPERATING INSTRUCTIONS



Visit our website at: <http://www.harborfreight.com>



**Read this material before using this product.
Failure to do so can result in serious injury.**

SAVE THIS MANUAL.

Copyright© 2006 by Harbor Freight Tools®. All rights reserved. No portion of this manual or any artwork contained herein may be reproduced in any shape or form without the express written consent of Harbor Freight Tools. Diagrams within this manual may not be drawn proportionally. Due to continuing improvements, actual product may differ slightly from the product described herein. Tools required for assembly and service may not be included.

For technical questions or replacement parts, please call 1-800-444-3353.
Revised Manual 11h

Specifications

ITEM	DESCRIPTION
Overall Dimensions	7-1/2"L x 5"W x 3-3/4"H
Handle Dimensions	1" Dia. x 3-1/8"L (left side only)
Inlet Size	1/4" - 18 NPT Female Thread
Max. Rated Air Pressure	90 PSI
Air Consumption	6 SCFM @ 90 PSI
Maximum Speed	10,000 RPM
Required Wheel Dimensions	4" Diameter x 1/4" Thickness (Grinding Wheel not included)
Arbor Diameter	5/8"
Spindle Thread	3/8"
Net Weight	2.65 Lbs.

Save This Manual

You will need the manual for the safety warnings and precautions, assembly instructions, operating and maintenance procedures, parts list and diagram. Keep your invoice with this manual. Write the invoice number on the inside of the front cover. Keep the manual and invoice in a safe and dry place for future reference.

Safety Warnings and Precautions

WARNING: When using tool, basic safety precautions should always be followed to reduce the risk of personal injury and damage to equipment.

Read all instructions before using this tool!

1. **Keep work area clean.** Cluttered areas invite injuries.
2. **Observe work area conditions.** Do not use machines or power tools in damp or wet locations. Don't expose to rain. Keep work area well lighted. Do not use electrically powered tools in the presence of flammable gases or liquids.
3. **Keep children away.** Children must never be allowed in the work area. Do not let them handle machines, tools, or extension cords.
4. **Store idle equipment.** When not in use, tools must be stored in a dry location to inhibit rust. Always lock up tools and keep out of reach of children.
5. **Do not force tool.** It will do the job better and more safely at the rate for which it was intended. Do not use inappropriate attachments in an attempt to exceed the tool capacity.

6. **Use the right tool for the job.** Do not attempt to force a small tool or attachment to do the work of a larger industrial tool. There are certain applications for which this tool was designed. Do not modify this tool and do not use this tool for a purpose for which it was not intended.
7. **Dress properly.** Do not wear loose clothing or jewelry as they can be caught in moving parts. Protective, electrically non-conductive clothes and non-skid footwear are recommended when working. Wear restrictive hair covering to contain long hair.
8. **Use eye and ear protection.** Always wear ANSI approved impact safety goggles. Wear a full face shield if you are producing metal filings or wood chips. Wear an ANSI approved dust mask or respirator when working around metal, wood, and chemical dusts and mists.
9. **Do not overreach.** Keep proper footing and balance at all times. Do not reach over or across running machines.
10. **Maintain tools with care.** Keep tools sharp and clean for better and safer performance. Follow instructions for changing accessories. Inspect tool cords periodically and, if damaged, have them repaired by an authorized technician. The handles must be kept clean, dry, and free from oil and grease at all times.
11. **Disconnect when not in use.** Disconnect tool from air compressor hose when not in use.
12. **Remove adjusting keys and wrenches.** Check that keys and adjusting wrenches are removed from the tool or machine work surface before plugging it in.
13. **Avoid unintentional starting.** Be sure the switch is in the Off position when not in use and before plugging in.
14. **Stay alert.** Watch what you are doing, use common sense. Do not operate any tool when you are tired.
15. **Take caution as some woods contain preservatives such as copper chromium arsenate (CCA) which can be toxic.** When working with these materials extra care should be taken to avoid inhalation and minimize skin contact.
16. **Check for damaged parts.** Before using any tool, any part that appears damaged should be carefully checked to determine that it will operate properly and perform its intended function. Check for alignment and binding of moving parts, and any other condition that may affect proper operation. Any part that is damaged should be properly repaired or replaced by a qualified technician. Do not use the tool if any switch does not turn On and Off properly.

17. **Guard against electric shock.** Prevent body contact with grounded surfaces such as pipes, radiators, ranges, and refrigerator enclosures.
18. **Replacement parts and accessories.** When servicing, use only identical replacement parts. Use of any other parts will void the warranty. Only use accessories intended for use with this tool. Approved accessories are available from Harbor Freight Tools.
19. **Do not operate tool if under the influence of alcohol or drugs.** Read warning labels on prescriptions to determine if your judgment or reflexes are impaired while taking drugs. If there is any doubt, do not operate the tool.
20. **Use proper size and type extension cord.** If an extension cord is required for an air compressor, it must be of the proper size and type to supply the correct current to the tool without heating up. Otherwise, the extension cord could melt and catch fire, or cause electrical damage to the tool. This tool requires use of an extension cord of 0 to **10 amps** capability (up to 50 feet), with wire size rated at **18 AWG**. Longer extension cords require larger size wire. If you are using the air compressor outdoors, use an extension cord rated for outdoor use. (signified by "WA" on the jacket).
21. **Maintenance.** For your safety, service and maintenance should be performed regularly by a qualified technician.
22. **Use clean, dry, regulated, compressed air at 90 PSI.** Do not exceed the recommended 90 PSI. Never use oxygen, carbon dioxide, combustible gases or any other bottled gas as a power source for these tools.

Note: Performance of this tool (if powered by line voltage) may vary depending on variations in local line voltage. Extension cord usage may also affect tool performance.

Warning: This product contains or produces a chemical known to the State of California to cause cancer and birth defects (or other reproductive harm). (California Health & Safety Code § 25249.5 et seq.).

Warning: The warnings, cautions, and instructions discussed in this instruction manual cannot cover all possible conditions and situations that may occur. It must be understood by the operator that common sense and caution are factors which cannot be built into this product, but must be supplied by the operator.

Special Warnings for This Tool

1. There are certain applications for which this tool was designed. Harbor Freight Tools strongly recommends that this tool not be modified and/or used for any application other than which it was designed.

2. All accessories must be rated for at least the RPM speed recommended on the tool's warning label. Wheels and other accessories running over rated speed can fly apart and cause injury.
3. For safest operation, it is recommended that only these accessories be used with this product: Abrasive Cut-Off Discs and Wheels, Flap Wheels, Wire Brushes, Wire Wheel Brushes.
4. Always use an approved and proper guard when using the above mentioned accessories. Each accessory must have the correct arbor size and must fit properly on the Gear Shaft. Make sure accessories are tightened down securely.
5. Always disconnect from power source before adding or removing accessories. Use a cloth or glove to protect hands from abrasion.
6. The Handle must be used at all times to maintain complete control of the tool. Two-handed operation is required at all times.

WARNING: Never install a carbide tipped or steel circular saw blade for use with this Angle Grinder! Never install a wood carving blade, carving disc with saw chain cutters, or a cutting carving disc on this Angle Grinder!

Unpacking

When unpacking, check to make all parts listed on Page 8 are included. If any parts are missing or broken, please call Harbor Freight Tools at the number on the cover of this manual.

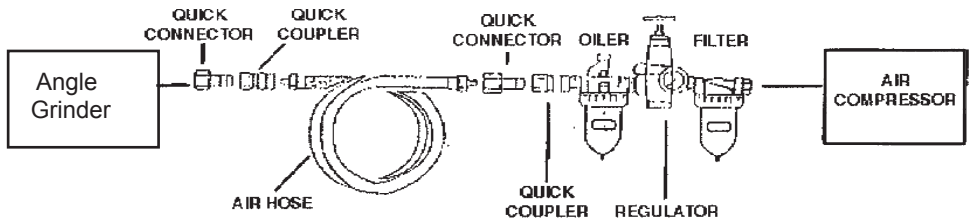

Air Connection

Note: Air Compressor is not supplied. You will need an Air Compressor with a minimum rating of One Horsepower, 6 SCFM delivery at 90 PSI, and a 12 Gallon Air Tank.

You may use Couplings (not supplied) as shown in the Diagram above. Do not connect Couplers directly to the Air Inlet. Doing so will increase the overall bulk of the tool and strain the Inlet Threads.

1. Be sure to follow all safety precautions as listed on Pages 2-5 of this manual.

2. Acquire a 1/4" NPT air fitting (not supplied) and screw into the Air Inlet fitting. Tighten with a wrench.
3. Attach a quick-coupler (not supplied) to the air fitting if desired. This allows quick exchange of the Air Hose to other air tools.
4. Once the air compressor is off, connect the Air Hose to the Air Inlet Coupling.

This air tool requires lubrication during operation. For best results, it is recommended to have an oiler and water filter in line with the air supply as shown. This will extend the life of the tool.

Attaching/Changing the Wheel Accessory

1. Fit the U-shaped end of the Stop Spanner [33] around the Gear Shaft [6] and hold in place to prevent the Shaft from spinning. Insert the two prongs on the end of the Disc Spanner [34] into the corresponding holes in the Disc Nut [1] and turn your wrist to unscrew the Disc Nut. See Fig. A, right.

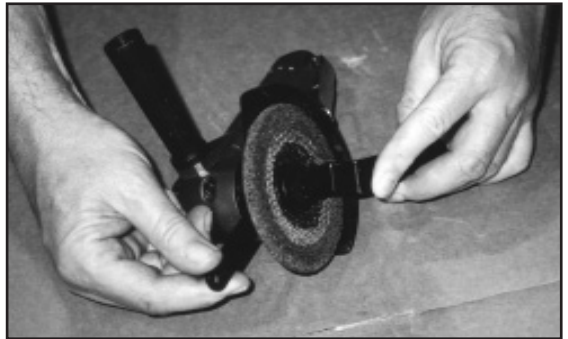

Fig. A

2. Slide the grinding wheel onto the Shaft.
 3. Replace the Disc Nut and tighten using the Stop Spanner and Disc Spanner.
- DANGER! Grinding wheel used must be rated at 11,000 RPM or higher.**

Operation

1. Always wear ANSI approved impact safety goggles when setting up and using this tool.
2. Tighten all work pieces to your work surface with a clamp or vise so that both of your hands are free to operate the Grinder.
3. Screw the Handle [35] into the threaded inlet on the side of the Angle Housing [13] as shown in the Assembly Diagram on Page 8.
4. Set the Air Compressor's pressure regulator to 90 PSI. Connect the Grinder to the Air Compressor's hose.
5. Check to be sure all attachments are secure before turning on the tool.

Adjust the Wheel Guard so that it provides a shield between you (the user) and the material you are working on. **The Wheel Guard must be in place at all times when using the Angle Grinder.**

6. Grip the Handle [35] with your left hand and the Housing [25] with your right hand. Depress the Lever [31] with your right hand to turn the tool on. Allow the motor to reach its full speed before grinding. Make sure the grinding wheel is rotating evenly and all parts appear to be working properly. Always maintain a firm grip with both hands when operating this tool.
7. To begin cutting or grinding, approach the material at an angle between 15 and 30 degrees to the wheel. Maintain that angle until you are finished cutting/grinding. Do not force the wheel or apply too much pressure. If the wheel slows down as you work with your material, you are applying too much pressure.
8. Once you have turned the Grinder off, continue to hold onto the tool with both hands until the motor stops completely before you set it down.

Maintenance and Troubleshooting

Caution: Always disconnect the Air Grinder from its compressed air supply source before performing any cleaning, servicing, or maintenance.

Before use, add a few drops of light tool oil into the air inlet (26). See assembly diagram on page 8. If the tool stops turning, the Rotor Blades (21) may be gummed up or damaged. You can remove and clean them or replace them if needed. See page 8. Call **1-800-444-3353** to order replacement parts.

PLEASE READ THE FOLLOWING CAREFULLY

THE MANUFACTURER AND/OR DISTRIBUTOR HAS PROVIDED THE PARTS DIAGRAM IN THIS MANUAL AS A REFERENCE TOOL ONLY. NEITHER THE MANUFACTURER NOR DISTRIBUTOR MAKES ANY REPRESENTATION OR WARRANTY OF ANY KIND TO THE BUYER THAT HE OR SHE IS QUALIFIED TO MAKE ANY REPAIRS TO THE PRODUCT OR THAT HE OR SHE IS QUALIFIED TO REPLACE ANY PARTS OF THE PRODUCT. IN FACT, THE MANUFACTURER AND/OR DISTRIBUTOR EXPRESSLY STATES THAT ALL REPAIRS AND PARTS REPLACEMENTS SHOULD BE UNDERTAKEN BY CERTIFIED AND LICENSED TECHNICIANS AND NOT BY THE BUYER. THE BUYER ASSUMES ALL RISK AND LIABILITY ARISING OUT OF HIS OR HER REPAIRS TO THE ORIGINAL PRODUCT OR REPLACEMENT PARTS THERETO, OR ARISING OUT OF HIS OR HER INSTALLATION OF REPLACEMENT PARTS THERETO.

Assembly Drawing

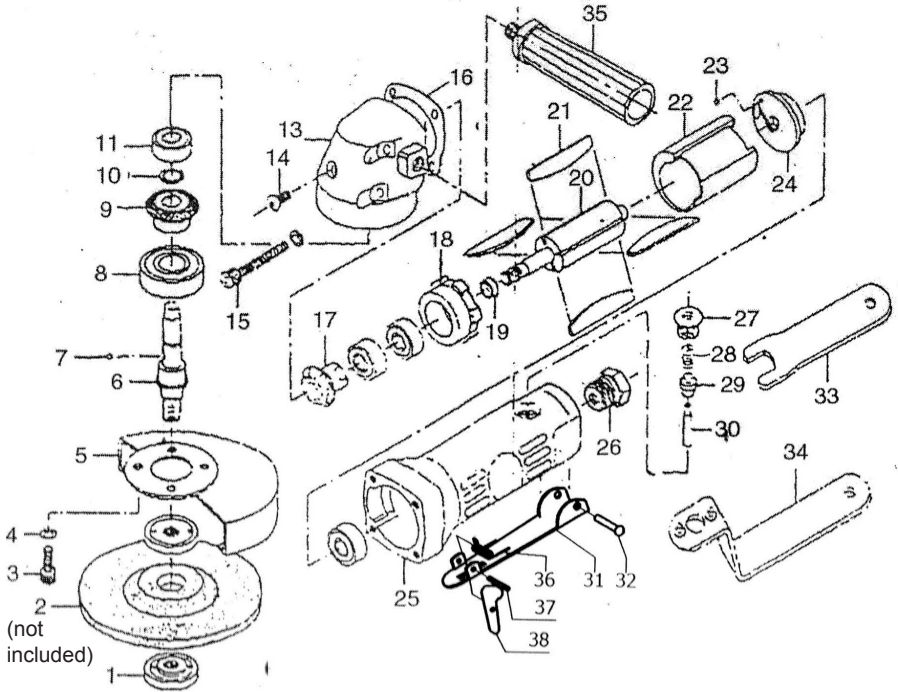

NOTE: Some parts are listed and shown for illustration purposes only and are not available individually as replacement parts.

Parts List

ITEM	DESCRIPTION	QTY	ITEM	DESCRIPTION	QTY
1	Disc Nut	2	19	Bearing Spacer	1
2	Grinding Wheel (not included)	1	20	Rotor	1
3	Screw	4	21	Rotor Blade	4
4	Spring Washer	8	22	Cylinder	1
5	Disc Cover	1	23	Steel Ball	1
6	Gear Shaft	1	24	Bear Plate	1
7	Key	1	25	Housing	1
8	Ball Bearing	1	26	Air Inlet	1
9	Bevel Gear	1	27	Screw	1
10	Retaining Ring	1	28	Spring	1
11	Ball Bearing	4	29	Valve Stem Bushing	1
12	Spacer	1	30	Valve Stem	1
13	Angle Housing	1	31	Lever	1
14	Screw	1	32	Pin	1
15	Screw	4	33	Stop Spanner	1
16	Packing	1	34	Disc Spanner	1
17	Pinion Gear	1	35	Handle	1
18	Front Plate	1	36	Spring	1
			37	Spring Pin	1
			38	Safety Lock	1

90 Day Warranty

Harbor Freight Tools Co. makes every effort to assure that its products meet high quality and durability standards, and warrants to the original purchaser that this product is free from defects in materials and workmanship for the period of 90 days from the date of purchase. This warranty does not apply to damage due directly or indirectly, to misuse, abuse, negligence or accidents, repairs or alterations outside our facilities, criminal activity, improper installation, normal wear and tear, or to lack of maintenance. We shall in no event be liable for death, injuries to persons or property, or for incidental, contingent, special or consequential damages arising from the use of our product. Some states do not allow the exclusion or limitation of incidental or consequential damages, so the above limitation of exclusion may not apply to you. THIS WARRANTY IS EXPRESSLY IN LIEU OF ALL OTHER WARRANTIES, EXPRESS OR IMPLIED, INCLUDING THE WARRANTIES OF MERCHANTABILITY AND FITNESS.

To take advantage of this warranty, the product or part must be returned to us with transportation charges prepaid. Proof of purchase date and an explanation of the complaint must accompany the merchandise. If our inspection verifies the defect, we will either repair or replace the product at our election or we may elect to refund the purchase price if we cannot readily and quickly provide you with a replacement. We will return repaired products at our expense, but if we determine there is no defect, or that the defect resulted from causes not within the scope of our warranty, then you must bear the cost of returning the product.

This warranty gives you specific legal rights and you may also have other rights which vary from state to state.