

# Owner's Manual & Safety Instructions

**Save This Manual** Keep this manual for the safety warnings and precautions, assembly, operating, inspection, maintenance and cleaning procedures. Write the product's serial number in the back of the manual near the assembly diagram (or month and year of purchase if product has no number). Keep this manual and the receipt in a safe and dry place for future reference.

21f

# **HAULMASTER**

## **3-POINT QUICK HITCH**



Visit our website at: <http://www.harborfreight.com>  
Email our technical support at: [productsupport@harborfreight.com](mailto:productsupport@harborfreight.com)

97214

When unpacking, make sure that the product is intact and undamaged. If any parts are missing or broken, please call 1-888-866-5797 as soon as possible.

Copyright© 2021 by Harbor Freight Tools®. All rights reserved.  
No portion of this manual or any artwork contained herein may be reproduced in any shape or form without the express written consent of Harbor Freight Tools. Diagrams within this manual may not be drawn proportionally. Due to continuing improvements, actual product may differ slightly from the product described herein. Tools required for assembly and service may not be included.

### **⚠ WARNING**

Read this material before using this product. Failure to do so can result in serious injury. **SAVE THIS MANUAL.**

## Specifications

Capacity	Fits most Category 1 Tractors up to 45 HP
Inside Clearance	27-3/16"
Max. Weight Capacity	2000 lb*

\*Depends on tractor's hitch capacity

# IMPORTANT SAFETY INFORMATION

## General Warnings

### 1. Work Area Safety

- a. **Keep work area clean and well lit.**  
*Cluttered or dark areas invite accidents.*
- b. **Keep children and bystanders away while operating a power tool.** *Distractions can cause you to lose control.*

### 2. Personal Safety

- a. **Stay alert, watch what you are doing and use common sense when using tool. Do not use tool while you are tired or under the influence of drugs, alcohol or medication.**  
*A moment of inattention while operating tool may result in serious personal injury.*
- b. **Use personal protective equipment. Always wear eye protection.** *Protective equipment such as dust mask, non-skid safety shoes, hard hat, or hearing protection used for appropriate conditions will reduce personal injuries.*
- c. **Do not overreach. Keep proper footing and balance at all times.** *This enables better control of the power tool in unexpected situations.*
- d. **Dress properly. Do not wear loose clothing or jewelry. Keep your hair, clothing and gloves away from moving parts.** *Loose clothes, jewelry or long hair can be caught in moving parts.*
- e. **Do not let familiarity gained from frequent use of tools allow you to become complacent and ignore tool safety principles.** *A careless action can cause severe injury within a fraction of a second.*
- f. Only use safety equipment that has been approved by an appropriate standards agency. Unapproved safety equipment may not provide adequate protection. Eye protection must be ANSI-approved and breathing protection must be NIOSH-approved for the specific hazards in the work area.
- g. Use as intended only.
- h. Inspect before every use; do not use if parts are loose or damaged.

- i. Do not exceed listed weight capacity.  
**Be aware of dynamic loading!**  
**Sudden load movement may briefly create excess load causing product failure.**
- j. This product is not a toy.  
Keep it out of reach of children.
- k. The warnings, precautions, and instructions discussed in this instruction manual cannot cover all possible conditions and situations that may occur. It must be understood by the operator that common sense and caution are factors which cannot be built into this product, but must be supplied by the operator.

### 3. Service

- a. **Have your power tool serviced by a qualified repair person using only identical replacement parts.** *This will ensure that the safety of the power tool is maintained.*
- b. Maintain product labels and nameplates. These carry important safety information. If unreadable or missing, contact Harbor Freight Tools for a replacement.

### 4. Specific Safety Warnings

- a. For off-road use only.
- b. Hitch connections need to be capable of supporting the weight of the Hitch and attached implement, plus load.

## **Components**

---

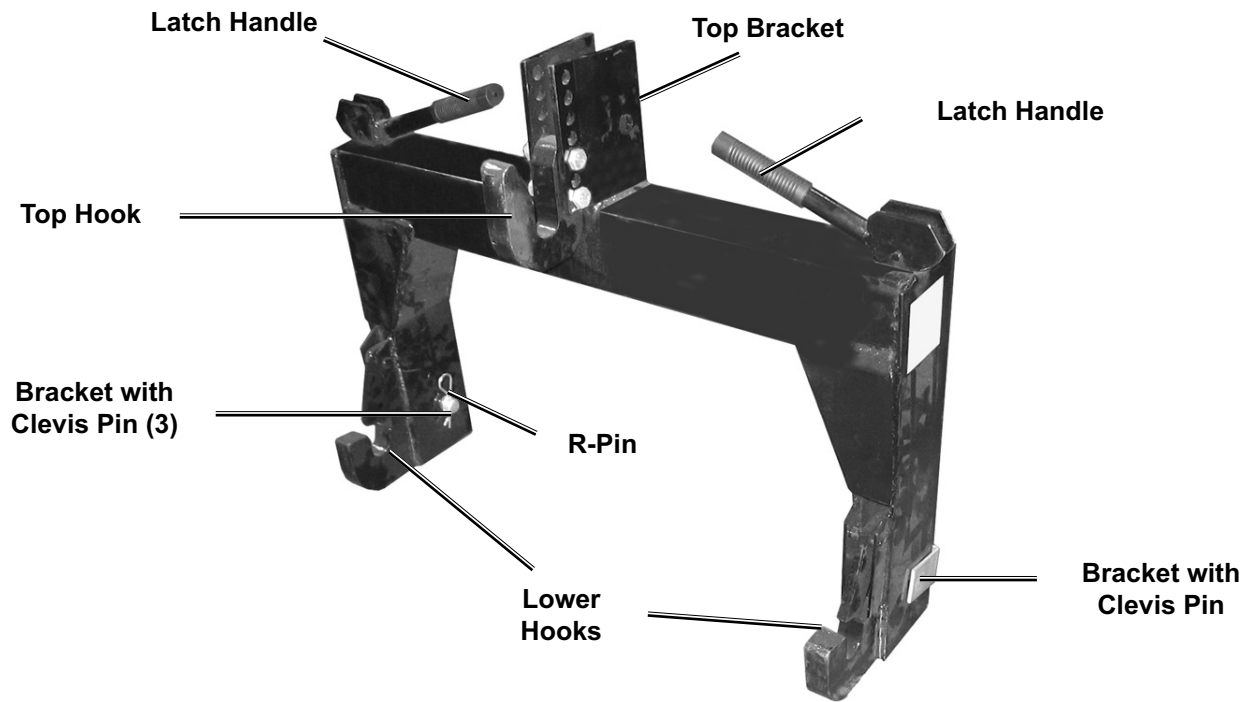

# Assembly



Read the **ENTIRE IMPORTANT SAFETY INFORMATION** section at the beginning of this document including all text under subheadings therein before set up or use of this product.

1. Fasten the Quick Hitch to the tractor's lift arms using a Bracket with Clevis Pin on each end. Secure with R-Pins. **See Figure A.**

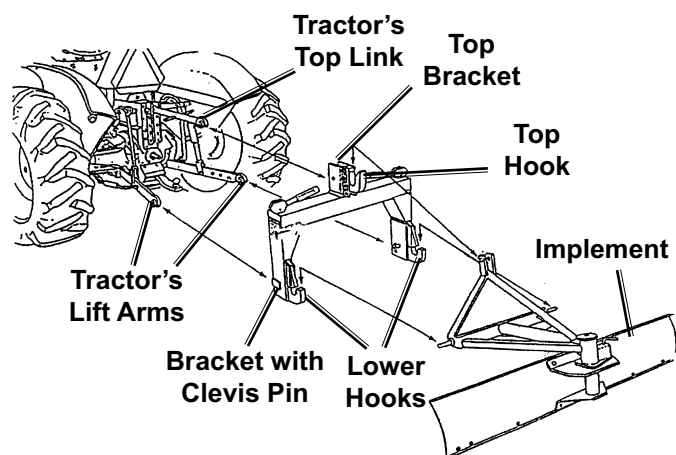

Figure A

2. Fasten the tractor's top link to the Top Bracket with the Top Link Pin (8).
3. Adjust the height of the Top Hook and connect it to the implement with a link pin (not included).
4. Insert the implement's lower mounts inside the Lower Hooks, and lock by pressing down the latch handles.
5. Check that all connections are tight before starting the work task.
6. If the tractor has stabilizer arms, they will not fit into the Quick Hitch mounting area along with the lift arms. Use stabilizer chains, or some other longer mounting pin (neither included) to fasten the Quick Hitch to the tractor.

## Mounting Non-ASAE Implements

**Note:** If the implement does not meet ASAE specifications, use Hitch Adapter (29309, sold separately).

1. Remove the Top Hook by taking out the two Hex Bolts (2), Lock Washers (6), and Nut (7). Save hardware.
2. Slide the Hitch Adapter over the Top Bracket and secure with Top Link Pin.

3. For most implements, the front hole (closest to implement) is recommended for the best vertical alignment.
4. Attach the implement to the Hitch Adapter with a Link Pin (sold separately).
5. Check that all connections are tight before starting a task.

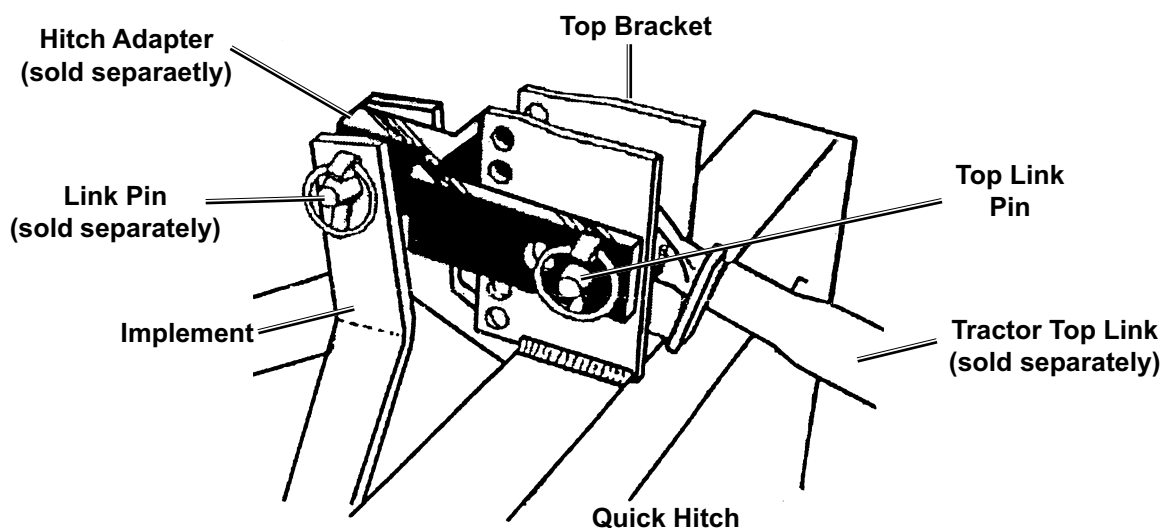

## Maintenance and Servicing Instructions



Procedures not specifically explained in this manual must be performed only by a qualified technician.

### **TO PREVENT SERIOUS INJURY FROM TOOL FAILURE:**

Do not use damaged equipment. If abnormal noise or vibration occurs, have the problem corrected before further use.

## Cleaning, Maintenance, and Lubrication

---

1. **BEFORE EACH USE**, inspect the general condition of the tool. Check for:
  - loose hardware,
  - misalignment or binding of moving parts,
  - cracked or broken parts, and
  - any other condition that may affect its safe operation.
2. **AFTER USE**, wipe external surfaces of the tool with clean cloth.
3. Lubricate the Quick Hitch periodically for best results.

## PLEASE READ THE FOLLOWING CAREFULLY

---

THE MANUFACTURER AND/OR DISTRIBUTOR HAS PROVIDED THE PARTS LIST AND ASSEMBLY DIAGRAM IN THIS DOCUMENT AS A REFERENCE TOOL ONLY. NEITHER THE MANUFACTURER OR DISTRIBUTOR MAKES ANY REPRESENTATION OR WARRANTY OF ANY KIND TO THE BUYER THAT HE OR SHE IS QUALIFIED TO MAKE ANY REPAIRS TO THE PRODUCT, OR THAT HE OR SHE IS QUALIFIED TO REPLACE ANY PARTS OF THE PRODUCT. IN FACT, THE MANUFACTURER AND/OR DISTRIBUTOR EXPRESSLY STATES THAT ALL REPAIRS AND PARTS REPLACEMENTS SHOULD BE UNDERTAKEN BY CERTIFIED AND LICENSED TECHNICIANS, AND NOT BY THE BUYER. THE BUYER ASSUMES ALL RISK AND LIABILITY ARISING OUT OF HIS OR HER REPAIRS TO THE ORIGINAL PRODUCT OR REPLACEMENT PARTS THERETO, OR ARISING OUT OF HIS OR HER INSTALLATION OF REPLACEMENT PARTS THERETO.

**Record Serial Number Here:**

---

**Note:** If product has no serial number, record month and year of purchase instead.

**Note:** Some parts are listed and shown for illustration purposes only, and are not available individually as replacement parts. Specify UPC 193175450111 when ordering parts.

# Parts List and Diagram

Part	Description	Qty
1	Main Frame	1
2	Hex Bolt, M12x65	2
3	Bracket with Clevis Pin	2
4	R-Pin	3
5	Hook	1
6	Nut (M12)	2
7	Lock Washer (M12)	2
8	Top Link Pin	1

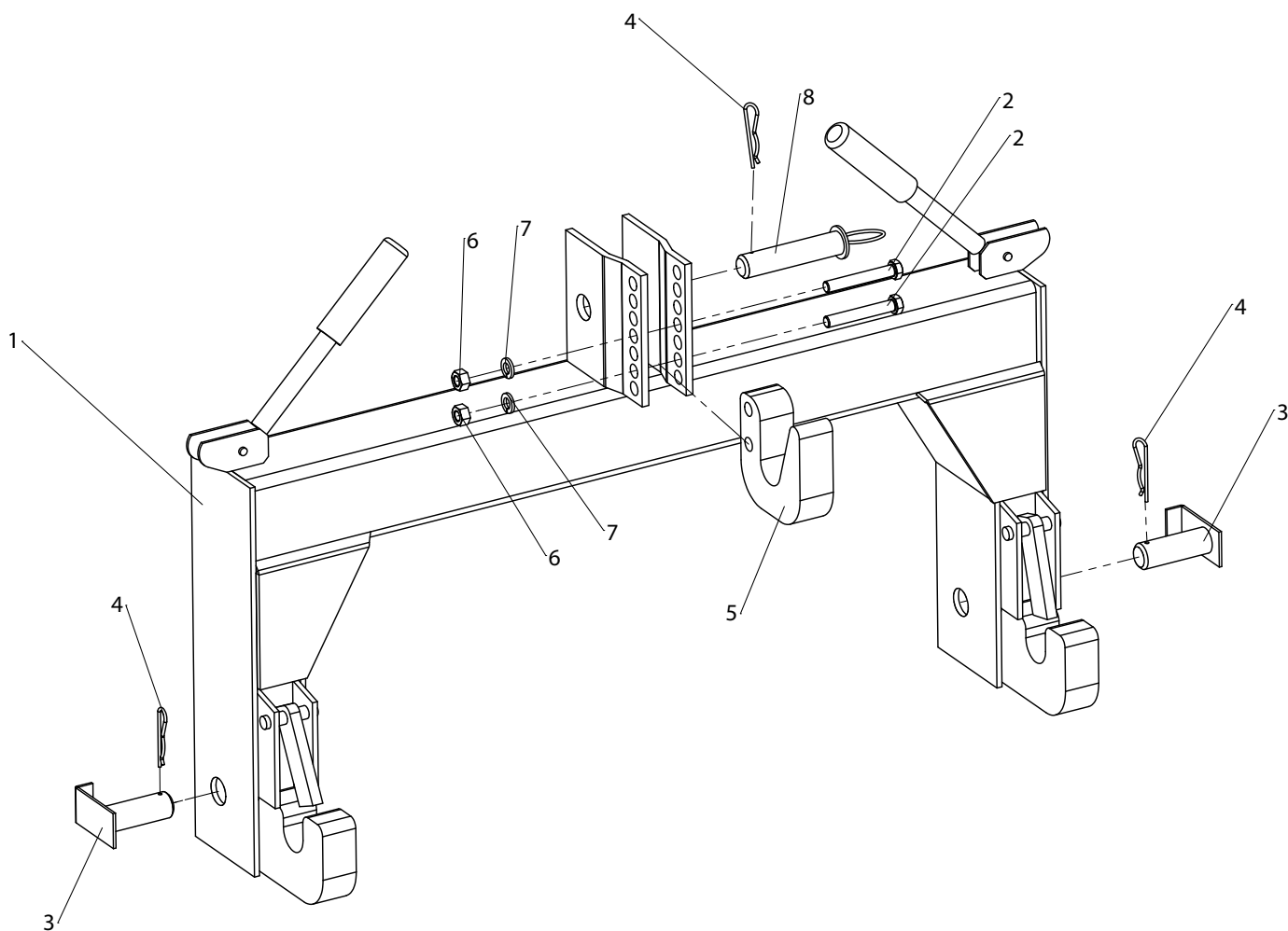

## Limited 90 Day Warranty

Harbor Freight Tools Co. makes every effort to assure that its products meet high quality and durability standards, and warrants to the original purchaser that this product is free from defects in materials and workmanship for the period of 90 days from the date of purchase. This warranty does not apply to damage due directly or indirectly, to misuse, abuse, negligence or accidents, repairs or alterations outside our facilities, criminal activity, improper installation, normal wear and tear, or to lack of maintenance. We shall in no event be liable for death, injuries to persons or property, or for incidental, contingent, special or consequential damages arising from the use of our product. Some states do not allow the exclusion or limitation of incidental or consequential damages, so the above limitation of exclusion may not apply to you. THIS WARRANTY IS EXPRESSLY IN LIEU OF ALL OTHER WARRANTIES, EXPRESS OR IMPLIED, INCLUDING THE WARRANTIES OF MERCHANTABILITY AND FITNESS.

To take advantage of this warranty, the product or part must be returned to us with transportation charges prepaid. Proof of purchase date and an explanation of the complaint must accompany the merchandise. If our inspection verifies the defect, we will either repair or replace the product at our election or we may elect to refund the purchase price if we cannot readily and quickly provide you with a replacement. We will return repaired products at our expense, but if we determine there is no defect, or that the defect resulted from causes not within the scope of our warranty, then you must bear the cost of returning the product.

This warranty gives you specific legal rights and you may also have other rights which vary from state to state.

The logo for Haulmaster, featuring the word "HAULMASTER" in a bold, italicized, sans-serif font. The letters are white with a thick black outline, and a registered trademark symbol (®) is located at the bottom right of the word.

26541 Agoura Road • Calabasas, CA 91302 • 1-888-866-5797