

U.S. General®

2-TRAY / 3-TRAY SERVICE CART

Models	97542
	97541

ASSEMBLY, OPERATING, AND MAINTENANCE INSTRUCTIONS



Diagrams within this manual may not be drawn proportionally.

Due to continuing improvements, actual product may differ slightly from the product described herein.

Distributed exclusively by Harbor Freight Tools®.

3491 Mission Oaks Blvd., Camarillo, CA 93011

Visit our website at: <http://www.harborfreight.com>



**Read this material before using this product.
Failure to do so can result in serious injury.
SAVE THIS MANUAL.**

Copyright© 2008 by Harbor Freight Tools®. All rights reserved. No portion of this manual or any artwork contained herein may be reproduced in any shape or form without the express written consent of Harbor Freight Tools.

For technical questions or replacement parts, please call 1-800-444-3353.

SAVE THIS MANUAL

Keep this manual for the safety warnings and precautions, assembly, operating, inspection, maintenance and cleaning procedures. Write the product's serial number in the back of the manual near the assembly diagram (or month and year of purchase if product has no number). Keep this manual and the receipt in a safe and dry place for future reference.

IMPORTANT SAFETY INFORMATION

In this manual, on the labeling, and all other information provided with this product:



This is the safety alert symbol. It is used to alert you to potential personal injury hazards. Obey all safety messages that follow this symbol to avoid possible injury or death.

DANGER

DANGER indicates a hazardous situation which, if not avoided, will result in death or serious injury.

WARNING

WARNING indicates a hazardous situation which, if not avoided, could result in death or serious injury.

CAUTION

CAUTION, used with the safety alert symbol, indicates a hazardous situation which, if not avoided, could result in minor or moderate injury.

NOTICE

NOTICE is used to address practices not related to personal injury.

CAUTION

CAUTION, without the safety alert symbol, is used to address practices not related to personal injury.

READ ALL INSTRUCTIONS

General Safety

1. **Keep your work area clean and well lit.** Cluttered benches and dark areas invite accidents.
2. **Keep bystanders, children, and visitors away while assembling this product.** Distractions can cause you to lose control. Keep children out of the work area.
3. **Stay alert. Watch what you are doing, and use common sense when assembling.**
4. **Dress properly. Do not wear loose clothing or jewelry. Contain long hair. Keep your hair, clothing, and gloves out of the way of jaws and clamps.** Loose clothes, jewelry, or long hair can be caught in moving parts.
5. **Keep proper footing and balance at all times.** Proper footing and balance enables better control of this product in unexpected situations.
6. **Use safety equipment.** Wear ANSI-approved goggles and heavy-duty gloves during assembly to prevent pinching of hands and fingers.

7. **Do not force the Service Cart.** Use the correct the Service Cart for your application.
8. **Maintain the Service Cart.** Check for breakage of parts and any other condition that may affect the Service Cart's operation. If damaged, have the Service Cart repaired before use. *Many accidents are caused by poorly maintained products.*
9. **Maintain the Service Cart with care.** The Service Cart must be kept clean, dry, and free from oil and grease at all times.
10. **Check for damaged parts.** Before using the Service Cart, any part that appears damaged should be carefully checked to determine that it will operate properly and perform its intended function. Check for alignment and binding of moving parts; any broken parts or mounting fixtures; and any other condition that may affect proper operation. Any part that is damaged should be properly repaired or replaced by a qualified technician.
11. **Replacement parts and accessories.** When servicing, use only identical replacement parts. Use of any other parts will void the warranty.
12. **Do not force the product.** Use the correct product for your application. The correct product will do the job better and safer at the rate for which it is designed. Do not force the product and do not use the product for a purpose for which it is not intended.
13. **Store idle products out of reach of children and other untrained persons.** This product is dangerous in the hands of untrained users.
14. **Check for misalignment or binding of moving parts, breakage of parts, and any other condition that may affect the product's operation.** If damaged, have the product serviced before using. Many accidents are caused by poorly maintained products.

SPECIFIC SAFETY RULES

1. **Do not stand, climb or ride on the Service Cart.**
2. **Do not exceed the maximum weight capacity of 150 Lbs. for each tray.** Do not exceed the maximum weight capacity of 450 lbs. for the 3-Tray Service Cart (97542) and 300 lbs. for the 2-Tray Service Car (97541).
3. **Set-up and use the Service Cart on a flat, even surface capable of supporting the weight of the Service Cart and the contents of each tray.**
4. **When servicing a product, use only identical replacement parts. Follow instructions in the "Inspection, Maintenance, And Cleaning" section of this manual.** Use of unauthorized parts or failure to follow maintenance instructions may lead to injury.
5. **Maintain labels and nameplates on the product.** These carry important information. If unreadable or missing, contact Harbor Freight Tools for a replacement.
6. **Maintain a safe working environment.** Make sure there is adequate surrounding workspace. Do not use this product in a damp or wet location.

7. Do not use the Service Cart for other than intended use.
8. The warnings, precautions, and instructions discussed in this instruction manual cannot cover all possible conditions and situations that may occur. It must be understood by the operator that common sense and caution are factors which cannot be built into this product, but must be supplied by the operator.



SAVE THESE INSTRUCTIONS.

SPECIFICATIONS

SKU 97541	Two Trays
SKU 97542	Three Trays
Dimensions	30" x 16"
Color/Finish/Materials	Powder coated sheet steel
Casters	360 degree with black rubber wheels and chrome plated steel body

UNPACKING

When unpacking, check to make sure that the item is intact and undamaged. If any parts are missing or broken, please call Harbor Freight Tools at the number shown on the cover of this manual as soon as possible.

ASSEMBLY INSTRUCTIONS



Read the **ENTIRE IMPORTANT SAFETY INSTRUCTIONS** section at the beginning of this manual including all text under subheadings therein before set up or use of this product.

Figure 1

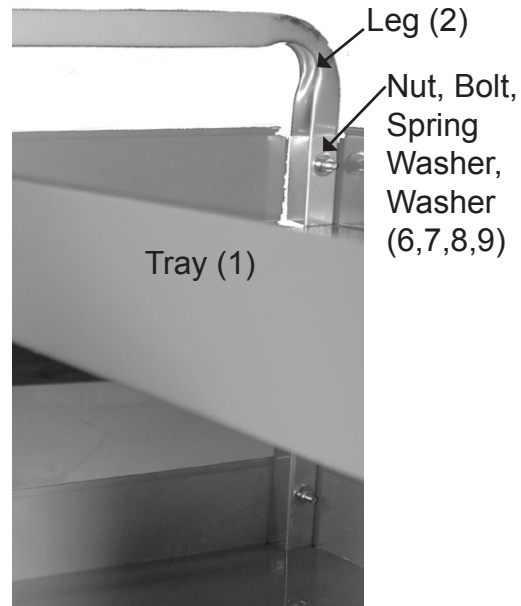

1. **For both SKUs 97541 and 97542:** Insert each Leg (2) down through one Tray (1) and slide the Tray (1) to the top of the Legs (2). Line Tray (1) up with holes in Legs (2)-see Figure 1.
2. Insert Bolt (6) with Washer (9) from outside the Tray (1) through Leg (2). Slide on another Washer (9), Spring Washer (8) and hand-tighten Nut (7) to secure in place.
3. **For SKU 97542 (3-Tray Cart) only:** Slide the middle Tray (1) into place on the Legs (2). Repeat Step 2.
4. Repeat Steps 1 and 2 for the Bottom Tray (2).

5. **For both SKUs 97541 and 97542:** With the Service Cart resting on a flat, even surface, make certain that the Legs (2) and Trays (1) are square and even. Tighten Nuts (7) firmly in place.
6. Insert the two Locking Swivel Castors (3) up into Plastic Holders (5) on one Leg (2). Using a rubber mallet, alternate tapping opposite sides of the Locking Swivel Castors (3) until they are firmly inserted into the Leg (2).
7. Insert two Swivel Castors (4) up into Plastic Holders (5) on one Leg (2). Using a rubber mallet, alternate tapping opposite sides of the Swivel Castors (4) until they are firmly inserted into the Leg (2).

OPERATING INSTRUCTIONS



Read the ENTIRE IMPORTANT SAFETY INFORMATION section at the beginning of this manual including all text under subheadings therein before set up or use of this product.

1. Load Trays as desired. Do not exceed the maximum weight capacity of 150 Lbs. for each Tray.
2. Once the Cart is at its desired location, press down on the levers on each Locking Swivel Castor (3) to lock the Castors in place.
3. Pull up on the brake levers on the Locking Swivel Castors (3) to release each Castor.
4. Make certain Castors are unlocked before moving the Service Cart. Do not try to move Cart while wheels are locked.

MAINTENANCE AND SERVICING



Procedures not specifically explained in this manual must be performed only by a qualified technician.

Cleaning, Maintenance, and Lubrication

1. **BEFORE EACH USE**, inspect the general condition of the Service Cart. Check for loose screws, misalignment or binding of moving parts, cracked or broken parts and any other condition that may affect its safe operation.
2. **AFTER USE**, clean external surfaces of Service Cart with clean, moist cloth. Do not use abrasives or harsh detergents, as these may damage the paint and finish on the Cart.
3. Periodically apply a drop of lubricating oil to the Casters.

PLEASE READ THE FOLLOWING CAREFULLY

THE MANUFACTURER AND/OR DISTRIBUTOR HAS PROVIDED THE PARTS LIST AND ASSEMBLY DIAGRAM IN THIS MANUAL AS A REFERENCE TOOL ONLY. NEITHER THE MANUFACTURER OR DISTRIBUTOR MAKES ANY REPRESENTATION OR WARRANTY OF ANY KIND TO THE BUYER THAT HE OR SHE IS QUALIFIED TO MAKE ANY REPAIRS TO THE PRODUCT, OR THAT HE OR SHE IS QUALIFIED TO REPLACE ANY PARTS OF THE PRODUCT. IN FACT, THE MANUFACTURER AND/OR DISTRIBUTOR EXPRESSLY STATES THAT ALL REPAIRS AND PARTS REPLACEMENTS SHOULD BE UNDERTAKEN BY CERTIFIED AND LICENSED TECHNICIANS, AND NOT BY THE BUYER. THE BUYER ASSUMES ALL RISK AND LIABILITY ARISING OUT OF HIS OR HER REPAIRS TO THE ORIGINAL PRODUCT OR REPLACEMENT PARTS THERETO, OR ARISING OUT OF HIS OR HER INSTALLATION OF REPLACEMENT PARTS THERETO.

PARTS LIST AND DIAGRAM FOR SKU 97541 2-TRAY SERVICE CART

Part	Description	Q'ty
1	Tray	2
2	Leg	2
3	Locking Swivel Castor	2
4	Swivel Castor	2
5	Plastic Holder	4
6	Bolt	8
7	Nut	8
8	Spring Washer	8
9	Washer	16

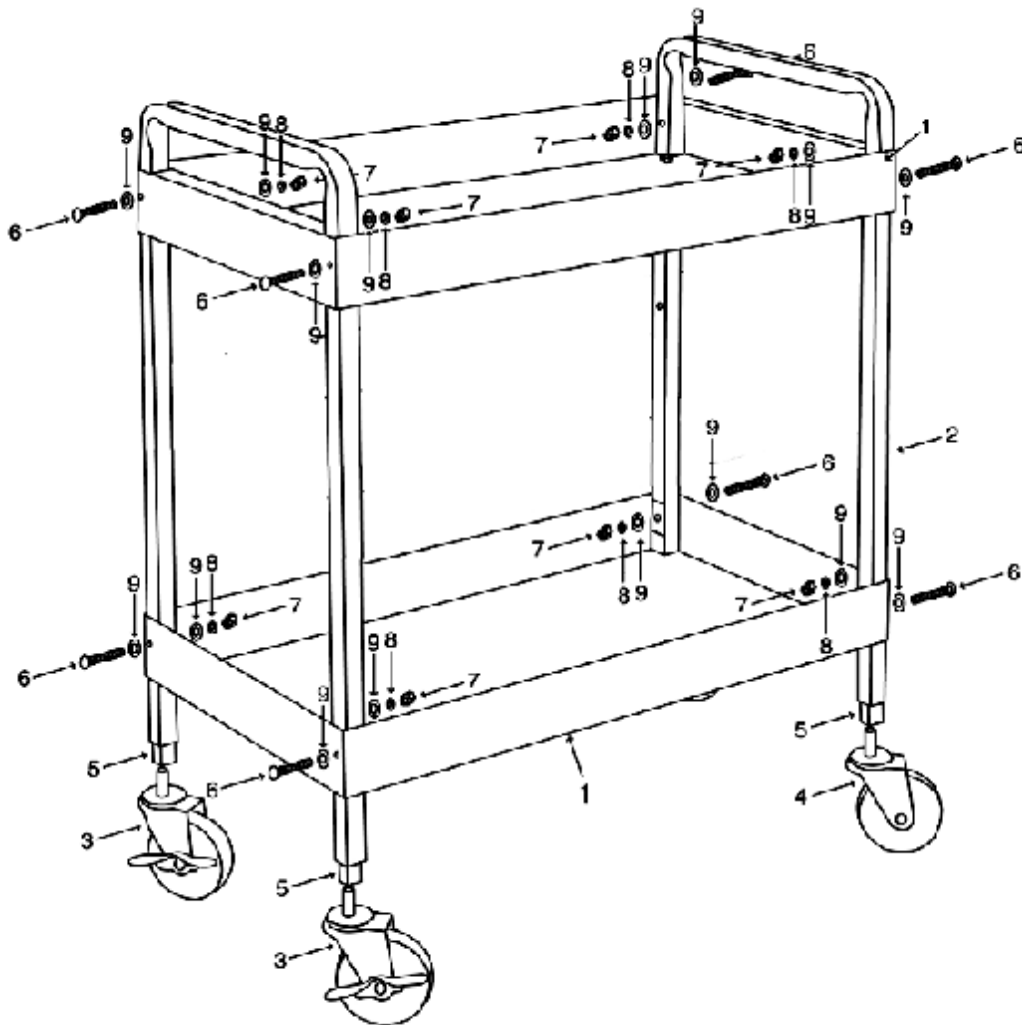

PARTS LIST AND DIAGRAM FOR SKU 97542 3-TRAY SERVICE CART

Part	Description	Q'ty
1	Tray	3
2	Leg	2
3	Swivel Castor with Lock	2
4	Swivel Castor	2
5	Plastic Holder	4
6	Bolt	12
7	Nut	12
8	Spring Washer	12
9	Washer	24

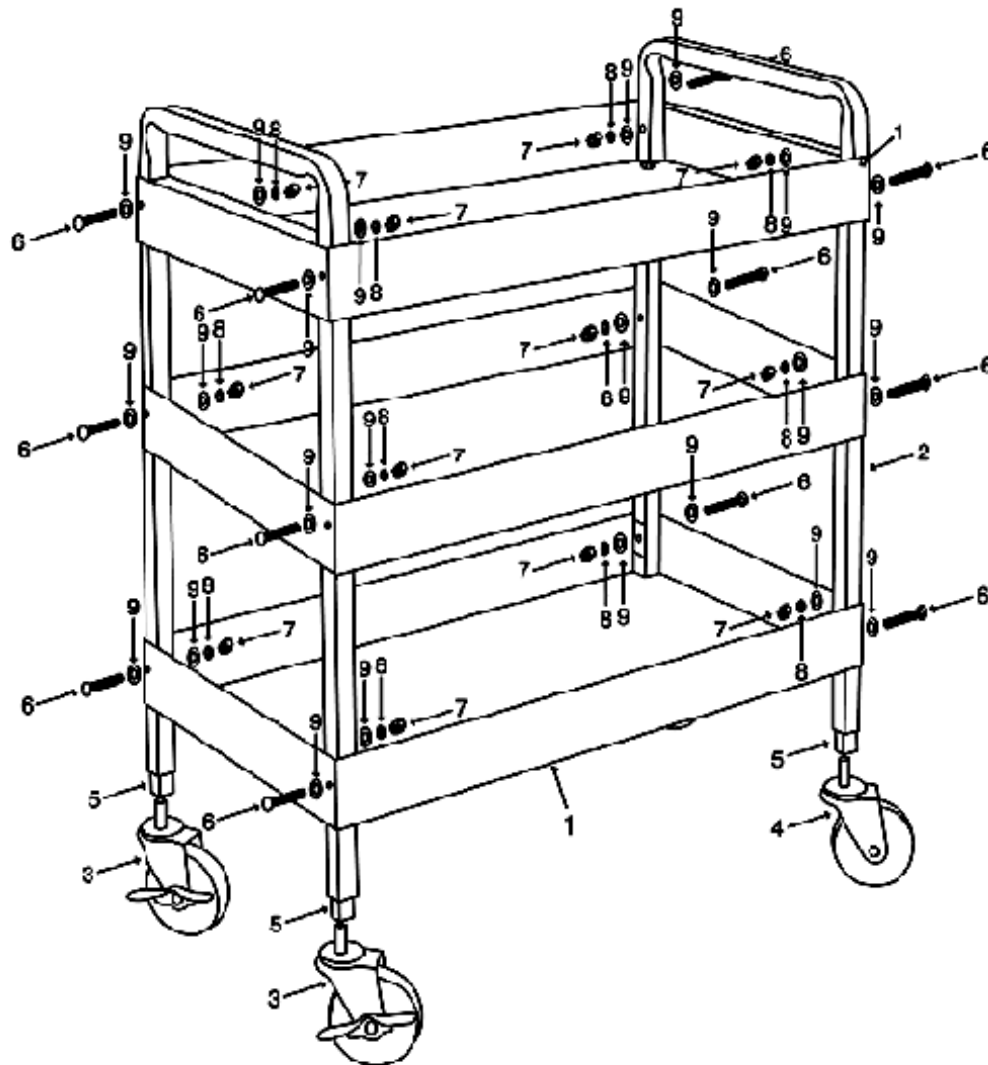

LIMITED 90 DAY WARRANTY

Harbor Freight Tools Co. makes every effort to assure that its products meet high quality and durability standards, and warrants to the original purchaser that this product is free from defects in materials and workmanship for the period of 90 days from the date of purchase. This warranty does not apply to damage due directly or indirectly, to misuse, abuse, negligence or accidents, repairs or alterations outside our facilities, criminal activity, improper installation, normal wear and tear, or to lack of maintenance. We shall in no event be liable for death, injuries to persons or property, or for incidental, contingent, special or consequential damages arising from the use of our product. Some states do not allow the exclusion or limitation of incidental or consequential damages, so the above limitation of exclusion may not apply to you. THIS WARRANTY IS EXPRESSLY IN LIEU OF ALL OTHER WARRANTIES, EXPRESS OR IMPLIED, INCLUDING THE WARRANTIES OF MERCHANTABILITY AND FITNESS.

To take advantage of this warranty, the product or part must be returned to us with transportation charges prepaid. Proof of purchase date and an explanation of the complaint must accompany the merchandise. If our inspection verifies the defect, we will either repair or replace the product at our election or we may elect to refund the purchase price if we cannot readily and quickly provide you with a replacement. We will return repaired products at our expense, but if we determine there is no defect, or that the defect resulted from causes not within the scope of our warranty, then you must bear the cost of returning the product.

This warranty gives you specific legal rights and you may also have other rights which vary from state to state.

3491 Mission Oaks Blvd. • PO Box 6009 • Camarillo, CA 93011 • (800) 444-3353