

Owner's Manual & Safety Instructions

Save This Manual Keep this manual for the safety warnings and precautions, assembly, operating, inspection, maintenance and cleaning procedures. Write the product's serial number in the back of the manual near the assembly diagram (or month and year of purchase if product has no number). Keep this manual and the receipt in a safe and dry place for future reference.

REV 15f

PITTSBURGH MOTORCYCLE

ITEM 98488

MOTORCYCLE WHEEL BALANCING STAND



Shown in use with Wheel and Tire (both not included).



Visit our website at: <http://www.harborfreight.com>
Email our technical support at: productsupport@harborfreight.com

When unpacking, make sure that the product is intact and undamaged. If any parts are missing or broken, please call 1-888-866-5797 as soon as possible.

Copyright© 2008 by Harbor Freight Tools®. All rights reserved.
No portion of this manual or any artwork contained herein may be reproduced in any shape or form without the express written consent of Harbor Freight Tools. Diagrams within this manual may not be drawn proportionally. Due to continuing improvements, actual product may differ slightly from the product described herein.
Tools required for assembly and service may not be included.

⚠ WARNING

**Read this material before using this product.
Failure to do so can result in serious injury.
SAVE THIS MANUAL.**

Specifications

Dual purpose stand to balance mounted tires. Accepts up to 12" W tires and $1\frac{19}{32}$ " (15mm) to $1\frac{1}{2}$ " (37mm) axles.

The following wheel alignment accessories may be required for alignment (sold separately)

1" Travel Machinist's Dial Indicator

1" Dial Indicator

Magnetic Base with Fine Adjustment

IMPORTANT SAFETY INFORMATION

Assembly Precautions

1. Assemble only according to these instructions. Improper assembly can create hazards.
2. Wear ANSI-approved safety goggles and heavy-duty work gloves during assembly.
3. Keep assembly area clean and well lit.
4. Keep bystanders out of the area during assembly.
5. Do not assemble when tired or when under the influence of drugs or medication.

Use Precautions

1. This product is not a toy. Do not allow children to play with or near this item.
2. Use for intended purpose only.
3. Inspect before use; do not use if parts are loose or damaged.
4. Maintain product labels and nameplates. These carry important safety information. If unreadable or missing, contact Harbor Freight Tools for a replacement.

Assembly Instructions



Read the **ENTIRE IMPORTANT SAFETY INFORMATION** section at the beginning of this document including all text under subheadings therein before set up or use of this product.

Figure 1

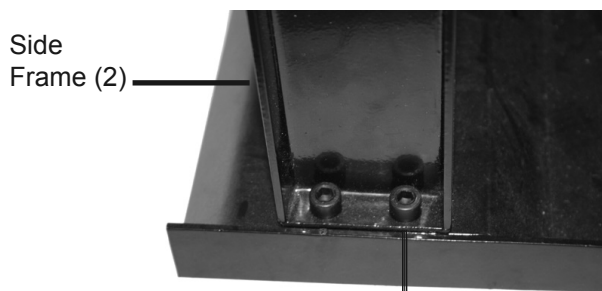

Socket Head Screw (9)

1. Attach each Side Frame (2) to the Base (1): With the face of the Side Frame (2) facing inward, insert two Socket Head Screw (9) down through the Side Frame and through the Base (1). Secure in place with two Lock Nuts (10)-see Figure 1.

Figure 2



2. Set the Axle (5) onto the Rollers (6) as shown in Figure 2.

Operating Instructions



Read the **ENTIRE IMPORTANT SAFETY INFORMATION** section at the beginning of this document including all text under subheadings therein before set up or use of this product.

1. Prior to use check to make certain that the Axle is straight, without any bends or damage.
 2. Back off both Socket Set Screw (12) and slide off one of the Centering Cones (4) from Axle (5). Support the wheel of the motorcycle in an upright position and slide the Axle (5) through the wheel hub and replace the Cone. Center the wheel on the Axle and slide both Cones securely against the hub. Tighten the Socket Cap Screws (12).
 3. Lift the wheel and position the Axle over the Rollers (6). Gently spin the wheel. The heavier side would roll to the bottom. With a chalk mark the tire at the upper most location (across from the heavy side).
 4. Lift the wheel assembly from the stand and place on the floor. Attach a balancing weight (not supplied) to the inner edge of the rim and reposition the wheel assembly over the Rollers (6).
- NOTE:** Use lightest possible weights. With try and error, you should be able to establish approximate required weights.
5. Gently spin the tire. Repeat steps 3 and 4 placing balancing weights on alternative sides of the tire rim.
 6. Continue to counter balance the wheel until it spins evenly and does not repeatedly stop at any specific point of its rotation.
 7. Once the wheel is balanced, remove the assembly and place on the floor, back off one Socket Set Screw (12) and remove the Centering Cone (4). Remove the Axle, replace the Cone and tighten the screw. Place the axle on the rollers.

Maintenance

1. Before each use, inspect the general condition of the Balancing Stand. Check for loose screws, misalignment or binding of moving parts, cracked or broken parts, and any other condition that may affect its safe operation.
2. Periodically lubricate contact points and Rollers with grease.

Replacing Rollers

1. Rollers (6) and Bearings (7) can be replaced by removing Socket Head Screw (11) and pulling Rollers off of the Balancing Stand.
2. Replace with new Rollers (6) and Bearings (7) and secure with Socket Set Screw (11). See Figure 2.
3. When not in use, store in a safe location away from children.

PLEASE READ THE FOLLOWING CAREFULLY

THE MANUFACTURER AND/OR DISTRIBUTOR HAS PROVIDED THE PARTS LIST AND ASSEMBLY DIAGRAM IN THIS DOCUMENT AS A REFERENCE TOOL ONLY. NEITHER THE MANUFACTURER OR DISTRIBUTOR MAKES ANY REPRESENTATION OR WARRANTY OF ANY KIND TO THE BUYER THAT HE OR SHE IS QUALIFIED TO MAKE ANY REPAIRS TO THE PRODUCT, OR THAT HE OR SHE IS QUALIFIED TO REPLACE ANY PARTS OF THE PRODUCT. IN FACT, THE MANUFACTURER AND/OR DISTRIBUTOR EXPRESSLY STATES THAT ALL REPAIRS AND PARTS REPLACEMENTS SHOULD BE UNDERTAKEN BY CERTIFIED AND LICENSED TECHNICIANS, AND NOT BY THE BUYER. THE BUYER ASSUMES ALL RISK AND LIABILITY ARISING OUT OF HIS OR HER REPAIRS TO THE ORIGINAL PRODUCT OR REPLACEMENT PARTS THERETO, OR ARISING OUT OF HIS OR HER INSTALLATION OF REPLACEMENT PARTS THERETO.

Parts List and Assembly Diagram

Part	Description	Qty.
1	Base	1
2	Side Frame	2
3	Mounting Plate	2
4	Centering Cone	2
5	Axle	1
6	Roller	4
7	Bearing	4
8	Sleeve	4
9	Socket Head Screw M8 x 20	4
10	Lock Nut M8	4
11	Socket Set Screw M8 x 25	4
12	Socket Head Screw M6 x 15	2

Note: Some parts are listed and shown for illustration purposes only, and are not available individually as replacement parts.

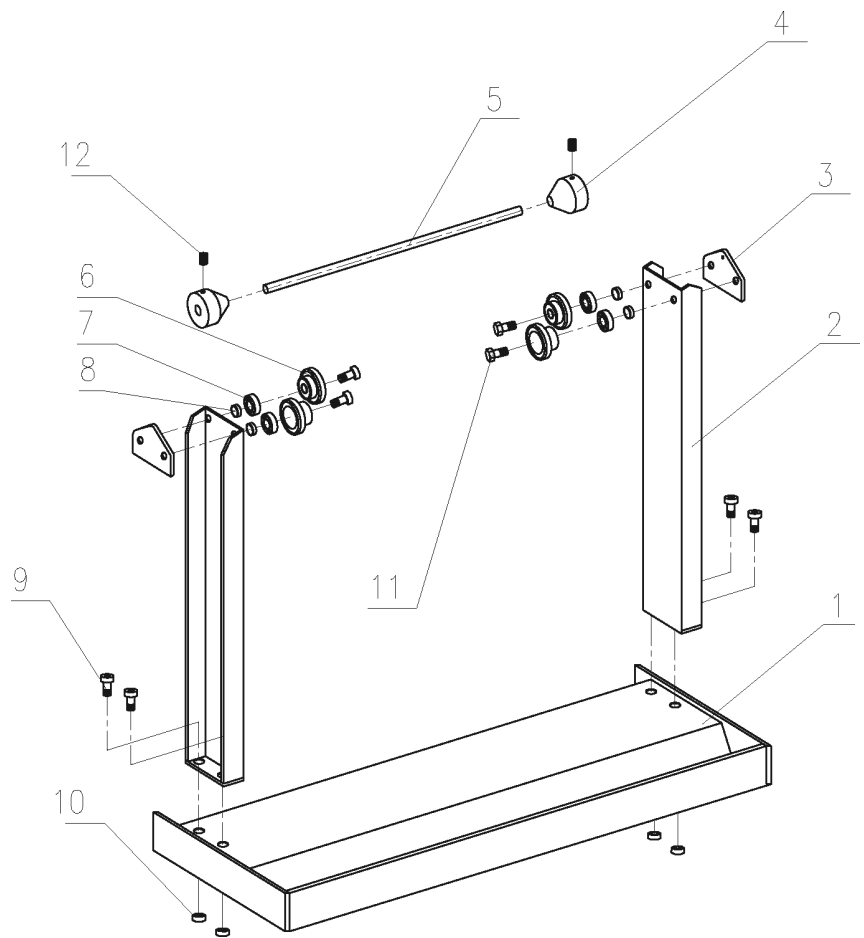

Limited 90 Day Warranty

Harbor Freight Tools Co. makes every effort to assure that its products meet high quality and durability standards, and warrants to the original purchaser that this product is free from defects in materials and workmanship for the period of 90 days from the date of purchase. This warranty does not apply to damage due directly or indirectly, to misuse, abuse, negligence or accidents, repairs or alterations outside our facilities, criminal activity, improper installation, normal wear and tear, or to lack of maintenance. We shall in no event be liable for death, injuries to persons or property, or for incidental, contingent, special or consequential damages arising from the use of our product. Some states do not allow the exclusion or limitation of incidental or consequential damages, so the above limitation of exclusion may not apply to you. THIS WARRANTY IS EXPRESSLY IN LIEU OF ALL OTHER WARRANTIES, EXPRESS OR IMPLIED, INCLUDING THE WARRANTIES OF MERCHANTABILITY AND FITNESS.

To take advantage of this warranty, the product or part must be returned to us with transportation charges prepaid. Proof of purchase date and an explanation of the complaint must accompany the merchandise. If our inspection verifies the defect, we will either repair or replace the product at our election or we may elect to refund the purchase price if we cannot readily and quickly provide you with a replacement. We will return repaired products at our expense, but if we determine there is no defect, or that the defect resulted from causes not within the scope of our warranty, then you must bear the cost of returning the product.

This warranty gives you specific legal rights and you may also have other rights which vary from state to state.

PITTSBURGH MOTORCYCLE

3491 Mission Oaks Blvd. • PO Box 6009 • Camarillo, CA 93011 • 1-888-866-5797